



Item # \_\_\_\_\_

# Range Series 36

## STANDARD FEATURES:

- ◆ Frame constructed of heavy gauge metal solidly welded.
- ◆ All stainless steel front, sides, valve cover and kick plate.
- ◆ Heavy gauge stainless steel plate ledge.
- ◆ 11" deep stainless steel high shelf on standard backguard with stainless steel splash panel.
- ◆ Cast iron top grates, 12" x 12", for open burners.
- ◆ Model RR-4-36 has two 18" w x 24" d top grates.
- ◆ Two piece, heavy duty lift off cast iron burner heads, rated at 30,000 BTU/hr.
- ◆ Spill protected standing pilot on each open burner for instant safe ignition.
- ◆ Oven contact surfaces have porcelain finish for easy maintenance.
- ◆ Oven door constructed for heavy use, easily removable for cleaning.
- ◆ Oven safety valve provides 100% shut down if pilot flame goes out.
- ◆ Piezo type, push button (matchless) ignition to light the standing pilot on the oven.
- ◆ "U" shape Oven Burner provides 35,000 BTU/hr for consistent heating. Oven design enhances airflow.
- ◆ 5/8" thick griddle plate, highly polished, with 3" wide grease trough. Griddle on the left is standard.
- ◆ Full width removable crumb/drip trays under open burners.



RR-6 Shown  
with optional casters

## OPTIONS:

- ◆ Griddle section. Highly polished 3/4" thick plate, from 12" to 36" wide.  
*Note: Each 12" of griddle replaces one pair of open burners.*
- ◆ Thermostatic control for the griddle (3/4" thick plate).
- ◆ Extra oven rack (One per oven is standard).
- ◆ 6" High Casters (2 locking, 2 swivel).
- ◆ 6" High stainless steel stub back in lieu of the high shelf assembly.
- ◆ Saute or wok style burner heads.
- ◆ 10" diameter stainless steel wok ring (fits over top grate).
- ◆ Convection oven (add suffix -C)
- ◆ Hot Top section sections 12" wide x 24" deep each.
- ◆ Seismic Flanged Feet.

*Royal Restaurant ranges have been designed to give the most useful features at an affordable cost. All stainless steel sides, and front panels, including the oven doors and kick plate are easily cleaned and rugged enough to withstand the constant heavy usage of a busy kitchen. Oven interiors are porcelain coated on all contact surfaces for fast and easy cleanup. The ovens are thermostatically controlled with 100% safety on the pilots to shut off the oven gas flow if the flame should go out. There is a push button ignitor for easy lighting of the oven pilot. 12" x 12" heavy cast iron grates (18" x 24" on RR-4-36) cover the unique two piece lift off burners, rated at 30,000 BTU/hr. each.*

**ROYAL RANGE OF CALIFORNIA, INC.**  
3245 CORRIDOR DRIVE, EASTVALE, CA 91752  
(800) 769-2414 in the U.S. (951) 360-1600 Fax: (951) 360-7500  
www.royalranges.com E-mail: royalrange@dsiextreme.com  
PRINTED IN THE U.S.A. (10/11)



# 36" Range Series Specifications

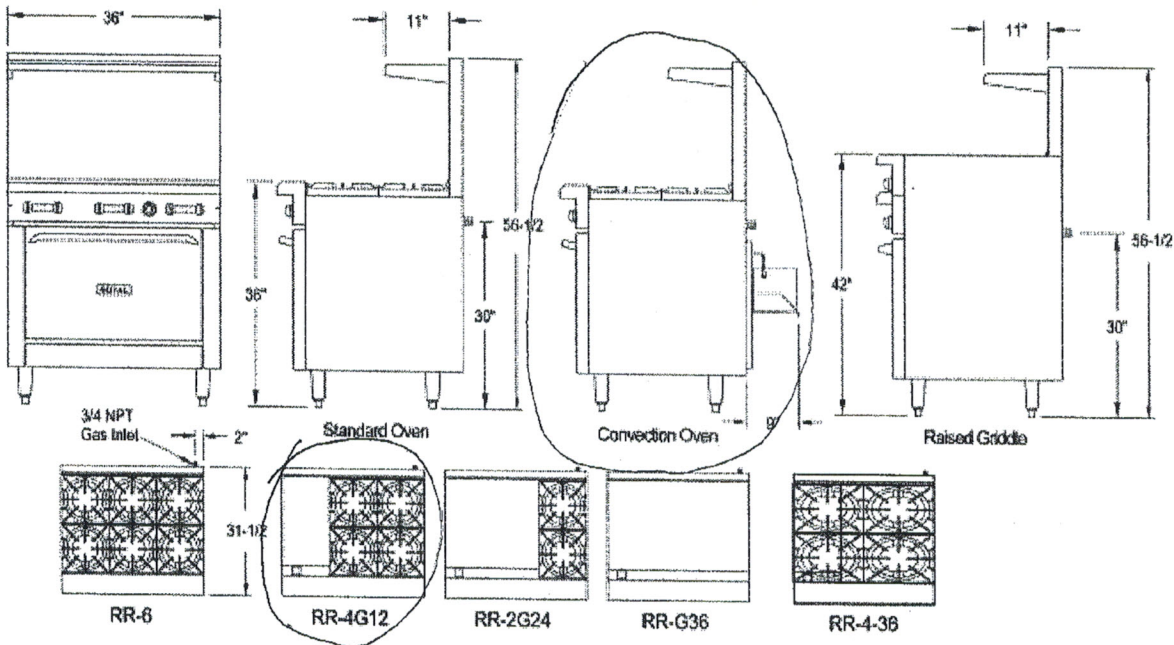

MODEL NUMBER <sup>1,2</sup>	OPEN BURNERS <sup>3</sup>	GRIDDLE BURNERS <sup>4</sup>	OVEN BURNERS <sup>5,1,2</sup>	TOTAL BTU	SHIP WEIGHT
RR-6	6	0	1	215,000	600 Lbs.
RR-4G12	4	1	1	175,000	620 Lbs.
RR-2G24	2	2	1	135,000	630 Lbs.
RR-G36	0	3	1	95,000	650 Lbs.
RR-4RG12	4	1	1	175,000	655 Lbs.
RR-6SU	6	0	1	215,000	610 Lbs.
RR-4-36	4	0	1	155,000	600 Lbs.

## NOTES:

1. For no oven (storage base) add suffix "-XB" and deduct 35,000 BTU's.
2. For Convection Oven (30,000 BTU/hr.) add suffix "-C" and deduct 5,000 BTU's.
3. Open Burners @ 30,000 BTU/HR. each.
4. Griddle Burners: 1 per 12" @ 20,000 BTU/HR. each.
5. Oven Burners @ 35,000 BTU/HR.

**Electrical requirements convection oven:** 120VAC 50-60hz, Single phase.  
8 amps per oven (single).

Two speed motor (1725 / 1140 RPM) 1/2 HP.

Provided with 6' power cord fitted with a standard three prong grounded plug.

**Gas Connection:** 3/4" NPT on the right hand rear of the appliance  
The pressure regulator (supplied) is to be connected here by the installer.

Gas pressure: 5" W.C. - Natural Gas  
10" W.C. - Propane

**Combustible Clearances:**

15 inches sides  
4 inches rear

**Non-combustible Clearances:**

0 inches sides  
0 inches rear

Specify type of gas and altitude,  
if over 2,000 feet, when ordering.

Due to continuing product development to ensure best possible performance, these specifications are subject to change without prior notification

ROYAL RANGE OF CALIFORNIA, INC. 3245 CORRIDOR DR. EASTVALE, CA 91752 [www.royalranges.com](http://www.royalranges.com)

(800) 769-2414, in the U.S. (951) 360-1600, Fax: (951) 360-7500, E-mail: [royalrange@dslextreme.com](mailto:royalrange@dslextreme.com) PRINTED IN THE U.S.A. (10/11)

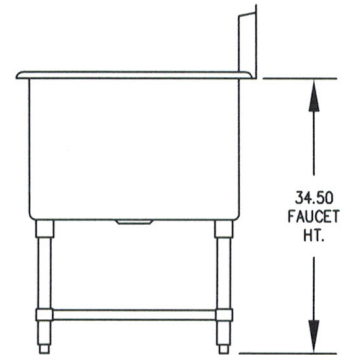
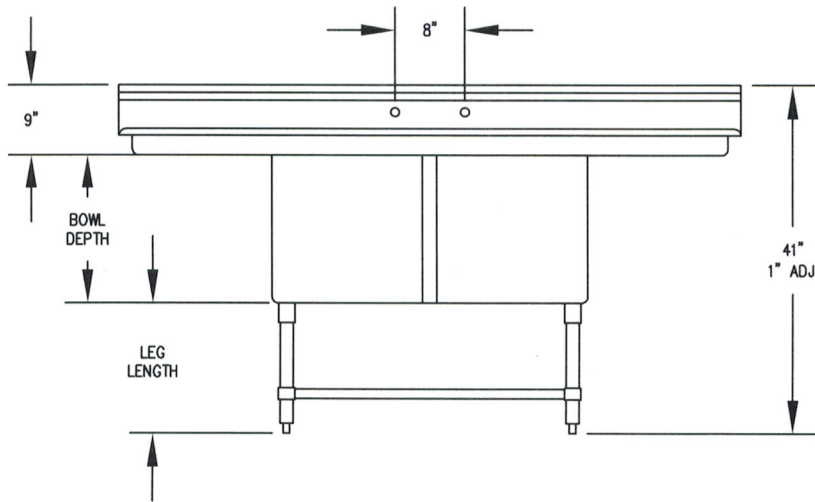
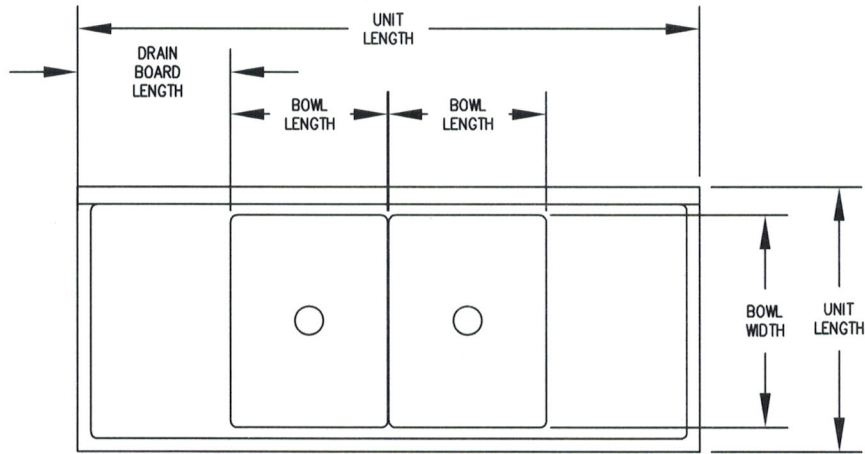

MODEL	GAUGE/SS	BOWL WIDTH	BOWL LENGTH	BOWL DEPTH	LEG LENGTH	UNIT WIDTH	UNIT LENGTH	DRAIN BOARD
ECS-2-2D	18/304	20	16	11	21	26	68	18
EIT-2-2D	16/304	24	24	14	18	30	85	18

KLINGERS TRADING  
 3009-B BANKERS INDUSTRIAL DRIVE  
 ATLANTA, GA 30360

VOICE 770-246-6006  
 FAX 770-246-6004



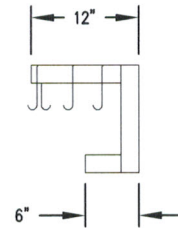
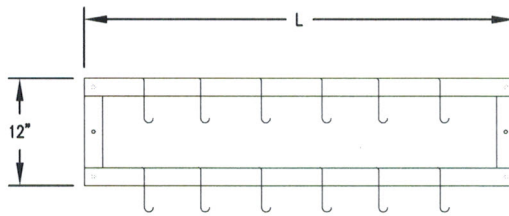

3/16" 430 S/S Bar 2" Width 304 S/S Bar  
 7/64" Thickness 2"X2" 304 S/S Angle Bar  
 18 PCS Plated Pot Hooks Included  
 Carton Box Packing

MODEL	GAUGE/SS	WIDTH	LENGTH	SHIPPING WEIGHT	UPS
SW-24	1/4"x2" BAR/304S	12"	24"	14lb	YES
SW-36	1/4"x2" BAR/304S	12"	36"	14lb	YES
SW-48	1/4"x2" BAR/304S	12"	48"	16lb	YES
SW-60	1/4"x2" BAR/304S	12"	60"	18lb	YES
SW-72	1/4"x2" BAR/304S	12"	72"	21lb	YES
SW-84	1/4"x2" BAR/304S	12"	84"	24lb	YES
SW-96	1/4"x2" BAR/304S	12"	96"	26lb	YES (OVERSIZE)

**KLINGERS TRADING**  
 3009-B BANKERS INDUSTRIAL DRIVE  
 ATLANTA, GA 30360  
 VOICE 770-246-6006  
 FAX 770-246-6004

