

Catalog Number:	Project Name:	Note:	Date:	Type:
-----------------	---------------	-------	-------	-------

9th Generation Flat Panel

Portor's 9th Generation BLP series produce industry-leading performance with deep energy savings and continuous dimming. The compact, slick profile produces uniform and glare free lumen output.

Perfect application for retail stores, schools, offices, markets and restaurant.



CONSTRUCTION

Constructed with a cold-rolled steel and extruded aluminum frame, finished with a durable matte white coating. Features a sleek, slim profile design with integrated T-bar mounting clips built directly into the fixture for easy installation.

OPTICS

The back-lit Frosted Polystyrene lens ensure uniform light distribution, while the diffuser lens minimizes glare and enhances overall energy efficiency.

ELECTRICAL

Luminaire is built with the highest quality driver that is Universal Voltage (120V-27V). Long life, high-efficacy, micro-power LEDs. Continuous dimming (0-10V) comes standard.

MOUNTING

Recessed ceiling mount ready (default). Surface mount and suspension mount with optional accessories.

CONTROLS

Options available for occupancy sensors with daylight harvesting function, TEELIO Bluetooth lighting controls, and Lutron AWN.

LISTING

UL Listed, DLC Premium Listed, IC rated

LIFESPAN

L70 > 100,000 hours

TECHNICAL SPECIFICATION

WATTAGE	22 (25W/30W/40W) / 24 (25W/30W/40W)
CCT	3500K/4000K/5000K
CRI	80+
DIMMING	1-10V dimming
VOLTAGE	120V-277V
POWER FREQUENCY	50/60 Hz
POWER FACTOR	>0.9
THD	≤20%
WORKING TEMPERATURE	-4°F ~ 122°F
IP RATING	IP40, For damp location
WARRANTY	5 year limited (Standard)



DIMENSION

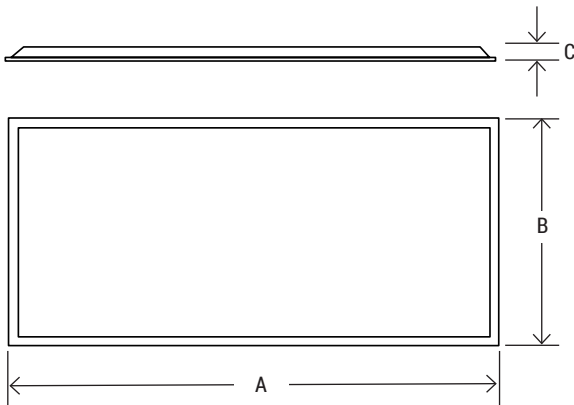







CATALOG NO.	PT-BLP-24-40-3CP-9	PT-BLP-22-40-3CP-9
A	47.8"	23.7"
B	23.7"	23.7"
C	1.5"	1.5"
Net Weight	7.41 lbs	3.91 lbs
Gross Weight	8.84 lbs	4.77 lbs

Catalog Number:	Project Name:	Note:	Date:	Type:
-----------------	---------------	-------	-------	-------

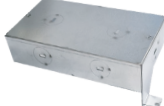
ORDERING SAMPLE: **PT-BLP-24-40-3CP-9-PT-BTC-6-PT-BTN-PT-EMA-8W-MC-5W-SC-6F**

PT-BLP	40	3CP	9					
Fixture				Controls/Sensors ³			EM Battery ³	
Series	Size	Max. Watt	CCT/Wattage	Generation	TEELIO ¹	Analog Sensors	Lutron Awn	
PT-BLP	22 (2' X 2')	40 (40W)	3CP (25W/30W/40W) (35K/40K/50K)	9 (9th Gen.)	PT-BTC-6 6A Bluetooth Power Pack	PT-MSH-LV-MW Internally Installed Low Voltage Microwave Sensor	AWN-RF RF only Athena Wireless Node (white) Lutron Model #: A-WN-D01-RF-WH	PT-EMA-P-8W 8W Panel AC EM Battery
	24 (2' X 4')	40 (40W)	3CP (25W/30W/40W) (35K/40K/50K)		PT-BTN Internally Installed Low Voltage Bluetooth Node	*Field Installation 1.DC12V		PT-EMA-8W 8W AC EM Battery Pack
					*These components are needed for field installation			PT-EMG-15W 15W AC EM Battery Pack

Mounting ³	Fixture Add-on ³			Warranty ³
Surface Mount Kit	Transformer ²	Junction Box	Whips	__ Blank (5 year standard) 7YR 7-year Limited Warranty 10YR 10-year Limited Warranty
__ Blank  SMK-UNI-22 2'x2' Surface Mount Kit SMK-UNI-24 2'x4' Surface Mount Kit	__ Blank  PT-SDT-325 325 VA Step down Transformer	__ Blank  JB-BLP Extension Junction Box for 2x2 and 2x4 panel	__ Blank  MC-5W-SC-6F 6ft 5-wire MC Whip with Screw-in Connector MC-6W-SC-6F 6ft 6-wire MC Whip with Screw-in Connector MC-5W-SN-HD-6F 6ft 5-wire MC Whip with Snap-in Head Connector MC-6W-SN-HD-6F 6ft 6-wire MC Whip with Snap-in Head Connector	
Pendant Mounting Kit				
__ Blank  FK-22 2'x2' Flange Kit FK-24 2'x4' Flange Kit				
Aircraft Cable				
__ Blank  A-CBL-BLP-224 5' Aircraft Cable for 1x4, 2x2, 2x4				

¹ DOWNLOAD THE TEELIO APP



² TRANSFORMER

PT-SDT-325 is a step-down auto-transformer designed to convert high voltage, low current power into low voltage, high current power. It has a maximum power rating of 325VA, which makes it suitable for use in a variety of applications, such as electrical power transmission, distribution, and electronic devices.

³ SOLD SEPARATELY

Catalog Number:	Project Name:	Note:	Date:	Type:
-----------------	---------------	-------	-------	-------

LUMEN PACKAGES

(Delivered lumens are based on the actual IES results)

CATALOG NUMBER	WATTAGE	CCT	DELIVERED LUMENS	EFFICACY (LM/W)	DLC ID
 PT-BLP-22-40-3CP-9	25W	3500K	3,385	135	S-1R4RPZ
		4000K	3,498	140	
		5000K	3,431	137	
	30W	3500K	4,028	134	
		4000K	4,173	139	
		5000K	4,061	135	
	40W	3500K	5,263	132	
		4000K	5,475	137	
		5000K	5,265	132	

CATALOG NUMBER	WATTAGE	CCT	DELIVERED LUMENS	EFFICACY (LM/W)	DLC ID
 PT-BLP-24-40-3CP-9	25W	3500K	3,453	138	S-JPS3Q5
		4000K	3,584	143	
		5000K	3,499	140	
	30W	3500K	4,038	135	
		4000K	4,208	140	
		5000K	4,090	136	
	40W	3500K	5,405	135	
		4000K	5,763	144	
		5000K	5,426	136	



WHAT'S IN THE BOX?

- Fixture
- Installation sheet

QTY/CARTON

4
PIECES

Catalog Number:	Project Name:	Note:	Date:	Type:
-----------------	---------------	-------	-------	-------

DESCRIPTION

- Made of 22 ga cold rolled steel
- Painted in white after fabrication
- Easily convert recessed troffer/panel to surface mount
- Available in 2'x4', 2'x2'

2' X 4'

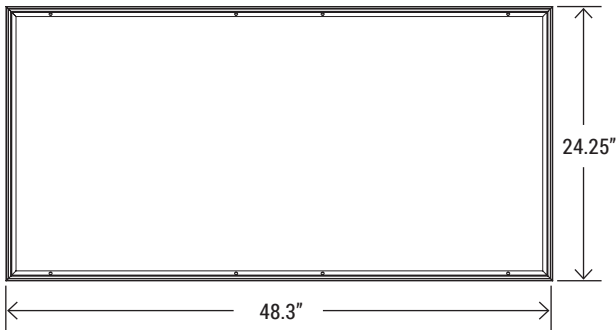

SMK-UNI-24

2' x 4' Surface Mount Kit for Troffer/Flat Panel

2' X 2'

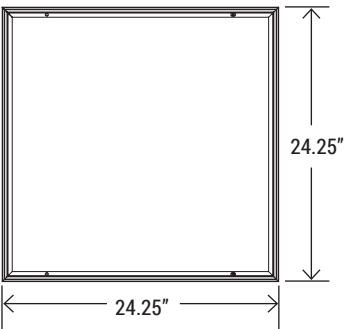

SMK-UNI-22

2' x 2' Surface Mount Kit for Troffer/Flat Panel

SIDE VIEW FOR ALL

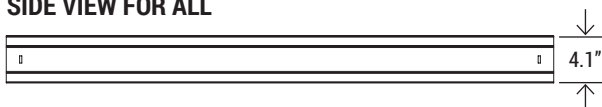

Catalog Number:	Project Name:	Note:	Date:	Type:
-----------------	---------------	-------	-------	-------

FK-24

2' x 4' Flange Kit

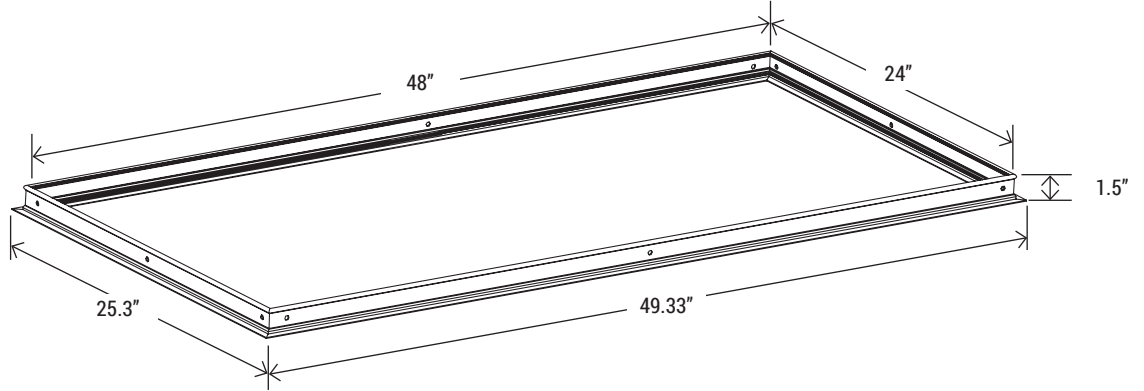

FK-22

2' x 2' Flange Kit

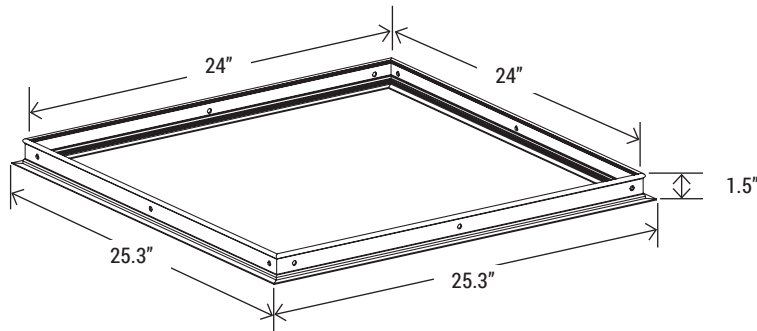

Catalog Number:	Project Name:	Note:	Date:	Type:
-----------------	---------------	-------	-------	-------

LIMITED STOCK

2' X 4'

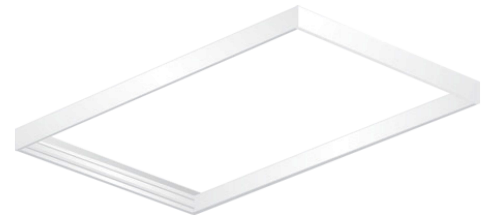
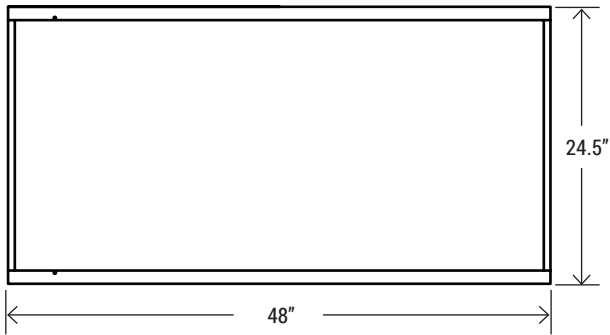

SMK-BLP-24

2' x 4' Surface Mount Kit for Flat Panel

2' X 2'

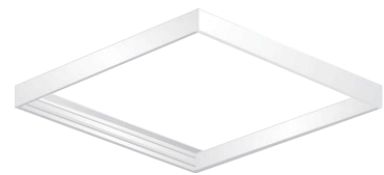
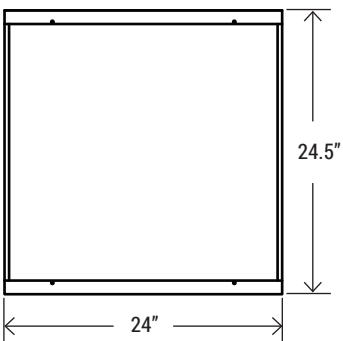

SMK-BLP-22

2' x 2' Surface Mount Kit for Flat Panel

SIDE VIEW FOR ALL

