

FEATURES

- 12" rough-in
- Vitreous china
- Elongated bowl
- 1.6 gpf
- 2" glazed trapway
- 10-7/8" x 9" water area
- Includes polished chrome trip lever
- Combination toilet
- Less seat and supply

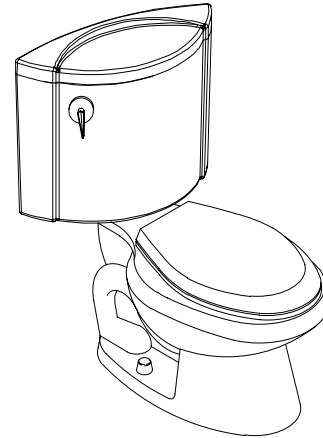

CODES/STANDARDS APPLICABLE

Specified model meets or exceeds the following:

- ASME/ANSI A112.19.2M
- ASME/ANSI A112.19.6M
- Energy Policy Act of 1992 (EPACT)
- IAPMO/UPC
- Canadian Standards Association (CSA)

COLORS/FINISHES

- 0 White
- Other Refer to Fixtures Price Book for additional colors

Accessories:

- CP Polished Chrome
- PB Polished Brass
- Other Refer to Price Book for additional colors

SPECIFIED MODEL:

Model	Description	Colors/Finishes	
K-3448	Elongated bowl toilet	<input type="checkbox"/> 0 White	<input type="checkbox"/> Other_____

Recommended Accessories			
K-4652	Lustra™ seat with cover	<input type="checkbox"/> 0 White	<input type="checkbox"/> Other_____
K-4652-A	Lustra™ seat with cover (includes anti-microbial agent)	<input type="checkbox"/> 0 White	
K-7637	Angle supply with stop	<input type="checkbox"/> CP	<input type="checkbox"/> PB <input type="checkbox"/> Other_____
Optional Accessories			
K-9438	Trip lever (non-CP)	<input type="checkbox"/> PB	<input type="checkbox"/> Other_____

PRODUCT SPECIFICATION:

The elongated toilet combination shall be 12" rough-in. Toilet shall be made of vitreous china. Toilet shall be 1.6 gpf. Toilet shall have 2" glazed trapway. Toilet shall have 10-7/8" x 9" water area. Toilet shall include polished chrome trip lever. Toilet shall be less seat and supply. Toilet shall be Kohler Model K-3448-_____.

FOLIO

PRODUCT INFORMATION

Fixture:	
Configuration	2-piece, elongated
Gallons per flush	1.6 gallons
Passageway	2"
Water area	10-7/8" x 9"
Water depth from rim	6"
Seat post hole centers	5-1/2"
Included Components:	
Bowl	K-4276
Tank	K-4447
Tank cover	84274
Trip lever	77785

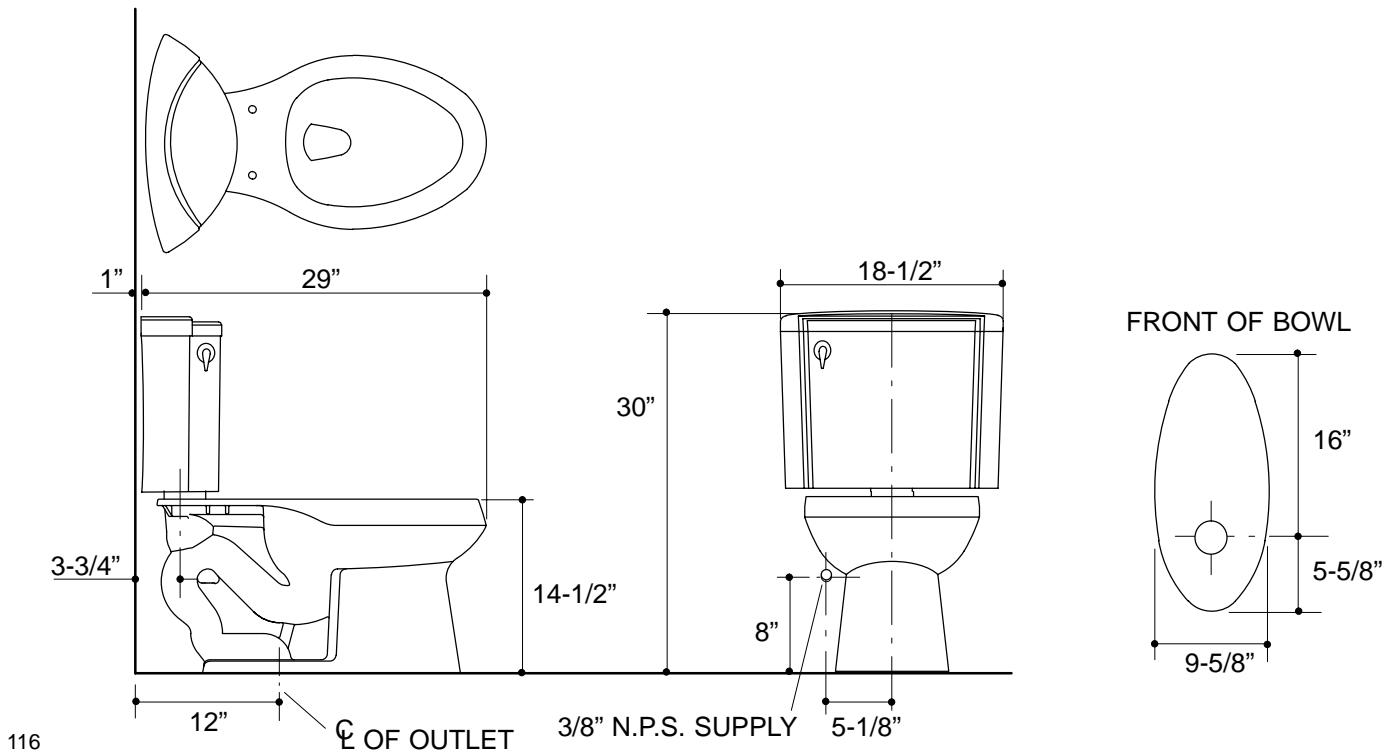

PRODUCT DIAGRAM