

## Emmedue M2 Building System

### Système de mur Wandsystem

The **Irish Agrément Board** is designated by Government to issue European Technical Approvals.

Irish Agrément Board Certificates establish proof that the certified products are 'proper materials' suitable for their intended use under Irish site conditions, and in accordance with the **Building Regulations 1997 to 2002**.

The **Irish Agrément Board** operates in association with the **National Standards Authority of Ireland (NSAI)** as the National Member of UEAtc.



#### PRODUCT DESCRIPTION:

The Emmedue M2 Building System consists of two types of wall panels. The first type is the single panel which consists of a polystyrene core with prefabricated zinc coated steel wire mesh reinforcement. Following erection on site it is encased in sprayed concrete. The second type of panel is the double panel which is a polystyrene permanent shutter for an insitu poured structural concrete core. Sprayed concrete also encases the polystyrene in the double panel. The single and double wall panels have zinc coated steel wire mesh reinforcement on each face. This consists of 2.5mm diameter reinforcement at 65mm centres. There are steel ties (82 per square metre) connecting the front and

the back meshes through the polystyrene. These ties, which are also zinc coated, are 3mm in diameter. It should be noted that the surface of the polystyrene is corrugated. The depth of corrugation is 10mm and the length is 70mm. The sprayed concrete has a minimum thickness of 35mm and a characteristic 28 days cube strength of 25MPa. It is fibre reinforced with polypropylene fibres to control shrinkage. Externally the sprayed concrete is finished as a scratch coat to give a key for an approved render.

The Emmedue M2 System also has similar floor, stairs and optional roof panels which are permanent shutters for insitu poured concrete. As for the wall panels, they consist of a polystyrene core with prefabricated zinc coated steel wire mesh reinforcement. The floor panels consist of reinforced T's – the main reinforcement in the T's is placed on site.

The finished system is structurally jointless between walls and floor elements.

This Certificate certifies compliance with the requirements of the Building Regulations 1997 to 2002.

**USE:**

The Emmedue M2 single panel is designed for use in the construction of two storey buildings of all purpose groups, designated in Irish Building Regulations TGB B, excluding purpose group 1(b). The single panel system is a cellular type construction where the maximum unbuttressed length of wall is not to exceed 7m, and clear vertical height not to exceed 3.0m.

The Emmedue M2 double panel is designed for all Purpose Groups defined in the TGD to Part B of the Building Regulations.

The system has been assessed for use as load bearing and non-load bearing walls, and for floor and roof panels in the construction of specifically designed buildings. Fire and sound rated walls may also be constructed using the system.

**MANUFACTURE AND MARKETING**

The product is manufactured and marketed by:

Emmedue M2,  
Botley Lane,  
Portarlinton,  
Co. Offaly.

## 1.1 ASSESSMENT

In the opinion of the Irish Agrément Board (IAB), the Emmedue M2 Building System when used as specified in this Irish Agrément certificate is satisfactory for the purpose defined above, and meets the requirements of the Building Regulations 1997 - 2002 as indicated in Section 1.2 of this Certificate.

## 1.2 BUILDING REGULATIONS 1997 to 2002

### REQUIREMENT:

#### *Part D - Materials and Workmanship*

**D3** – The Emmedue M2 Building System, as certified in this Certificate, is comprised of proper materials fit for their intended use (see Parts 3 and 4 of this Certificate).

**D1** – The Emmedue M2 Building System, used in accordance with this Certificate, meets the requirements for workmanship.

#### *Part A – Structure*

##### **A1 – Loading**

The Emmedue M2 Building System, as certified in this Certificate, has adequate strength and stability (see Parts 3 and 4 of this Certificate).

##### **A2 – Ground Movement**

The Emmedue M2 Building System, as certified in this Certificate, can be readily incorporated into structures which will meet this requirement.

##### **A3 - Disproportionate Collapse**

The Emmedue M2 Building System, as certified in this Certificate, can be incorporated into structures that will meet this requirement.

#### *Part B – Fire Safety*

##### **B2 – Internal Fire Spread (linings)**

The panels are non-combustible and have a Class 0 'spread of flame' rating. Surface spread of flame rating of the finished construction will be determined by the surface spread of flame rating of the lining materials used.

##### **B3 – Internal Fire Spread (structure)**

The Emmedue M2 Building System, as certified in this Certificate, will meet this requirement.

##### **B4 – External Fire Spread**

The Emmedue M2 Building System has a spread of flame rating equivalent to Class 0 on both faces. In respect of 'Spread of Flame', this is the highest performance classification set out in the Building Regulations 1997 to 2002.

#### *Part C – Site Preparation and Resistance to Moisture*

##### **C4 – Resistance to Weather and Ground Moisture**

The Emmedue M2 Building System, used in accordance with Part 3 of this Certificate, will have adequate weather resistance in all exposures, will resist the passage of moisture from whatever source and will prevent surface or interstitial condensation.

#### *Part E – Sound*

##### **E1 – Airborne Sound (walls)**

The Emmedue M2 Building System, as certified in this Certificate, will meet this requirement.

##### **E2 and E3 – Airborne and Impact Sound (floors)**

The Emmedue M2 Building System, as certified in this Certificate, will meet this requirement.

#### *Part F – Ventilation*

##### **F1 – Means of Ventilation**

Adequate building ventilation openings can be provided in walls constructed with the Emmedue M2 Building System. It is essential that ventilation ducts through such walls are fully sealed from any cavities within the walls or from contact with the cut edges of adjacent materials.

#### *Part J – Heat Producing Appliances*

##### **J3 – Protection of Building**

When used in accordance with Section 4.1 of this Certificate, the Emmedue M2 Building System can meet the Regulation requirements.

#### *Part L – Conservation of Fuel and Energy*

##### **L1 – Conservation of Fuel and Energy**

The Emmedue M2 Building System will contribute to enabling a building to meet this requirement.

#### *Part M – Access for People with Disabilities*

##### **M1 – Access and Use**

The Emmedue M2 Building System can incorporate this requirement.

**2.1 PRODUCT DESCRIPTION**

**2.1.1 Single Panel Construction**

Buildings constructed using this system shall have not more than two floors - ground floor and first floor - with the upper floor being constructed of Emmedue M2 ribbed floor panels (see figure 1) and covered with normal lightweight covering including clay or concrete pantiles. Load bearing concrete cores will be designed by structural engineer and reinforcement specified to IS 326/Eurocode 2.

External walls shall be constructed using Emmedue M2 single panels (see figure 2) each consisting of 12mm render on 35mm sprayed concrete on either 155mm (25kg/m<sup>3</sup>) or 170mm (15kg/m<sup>3</sup>) polystyrene, with an inner layer of 35mm sprayed concrete finished with a 4mm plaster skim coat (Figure 1). The sprayed concrete shall have a minimum characteristic strength of 25MPa at 28 days.

Internal load bearing walls shall be constructed as above using Emmedue M2 single panels. The minimum polystyrene core thickness shall be 65mm.

Load bearing party walls between dwellings shall be constructed using Emmedue M2 double panels (see figure 3) with density not less than 415kg/m<sup>2</sup>, consisting of a minimum 100mm thick concrete core (30MPa) between two layers of 65mm polystyrene (25kg/m<sup>3</sup>), which shall have a 35mm concrete (25 MPa) sprayed onto them.

Non load bearing partitions shall be constructed using the Emmedue M2 single panel incorporating 25mm of sprayed concrete both sides of a polystyrene core (15kg/m<sup>3</sup>) of varying thickness (40mm – 400mm).

The standard reinforcement is zinc coated electrowelded mesh reinforcement (2.5mm diameter at 65mm centres) and cross ties (3mm diameter at 82 number per square meter).

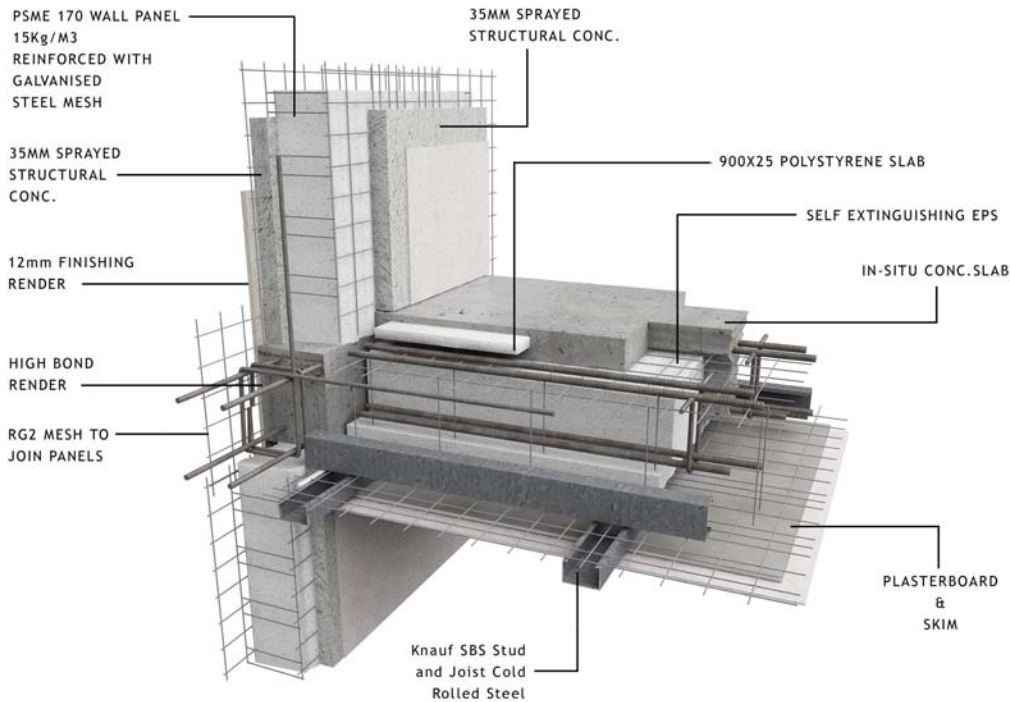

**Figure 1: Emmedue single panel wall/floor junction**

### Maximum Loads

Vertical imposed loads shall be in accordance with the requirements of Eurocode 1/ BS 6399

Wind loadings shall be in accordance with the requirements of BS 6399.

### Lateral Support and End Restraint

The ends of every load-bearing wall shall be securely anchored to a buttressing wall over its full height. Longer walls shall be provided with intermediate lateral restraint dividing the wall into distinct lengths by buttressing walls which provide support over the full height.

### Interaction of Elements

Walls shall extend to the full height of each storey and shall be provided with horizontal lateral supports. A ring beam (Figure 2) is constructed on each floor in accordance with M2 Building System Operations Manual. Floors and roofs shall act to transfer lateral forces from walls to buttressing walls and be constructed in accordance with Emmedue M2 details. Roofs shall be strapped to walls in accordance with Emmedue M2 details and designed to resist both horizontal and vertical forces arising from dead, imposed and wind loads.

### 2.1.2 Double Panel Construction

The Emmedue M2 double panel consists of polystyrene permanent shuttering with external mesh reinforcement on both sides of the polystyrene, and steel ties tying the mesh reinforcement across the polystyrene and the concrete core (Figure 3). The mesh reinforcement and ties are as per the single panel.

The double panel system can be designed for use in buildings up to four storeys in height using IS 326/Eurocode 2

All design should be undertaken by a chartered structural engineer.

### 2.1.3 Chimneys

Chimneys are outside the scope of the Emmedue M2 System. However, the system can incorporate an IAB approved pre-fabricated chimney block system. The requirements of Clause 2.15 of TGD to Part J of the Building Regulations require that combustible material such as polystyrene insulation have at least the following separation distance:

- a) 200mm from a flue, or
- b) 40mm from the outer surface of a brick or blockwork chimney or fireplace recess.

### 2.1.4 Concrete

The typical specifications for the sprayed and in-situ poured concrete are as follows:

- Sprayed fibre reinforced concrete for wall panels – 25MPa
- In-situ poured concrete in double panel walls – 30MPa
- In-situ poured concrete in floor panels – 30MPa

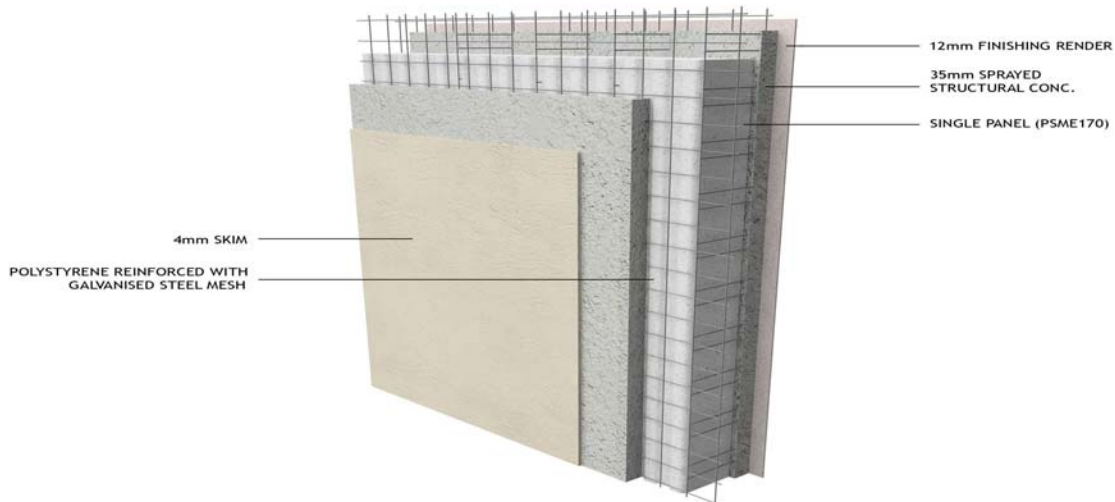

Figure 2: Emmedue single panel

### 2.1.5 Polystyrene

The polystyrene insulation is manufactured to comply with the requirements of IS EN 13163:2001.

Test	Density	
	15 kg/m <sup>3</sup>	25 kg/m <sup>3</sup>
Thermal conductivity (λ) (W/mK)	(0.034), (0.0371)	(0.0313), (0.0353) (0.0311), (0.032) (0.0318), (0.032)
Density (kg/m <sup>3</sup> )	(14.8/15.5), (16.0/16.0)	(23.1/25.3), (21.1/24.6), (24.3/23.9), (24.3/23.3) (24.2/24.0), (24.2/25.2)
Compressive strength @ 10% deformation (kPa)	(70), (68), (71)	(126), (127), (118)
Long term water absorption		
- by total immersion (kg/m <sup>3</sup> )	(3.4), (3.8), (2.3), (3.4)	
- by partial immersion (kg/m <sup>2</sup> )	(0.1), (0.1), (0.0), (0.1)	

**Table 1: Polystyrene Test Results**

### 2.1.6 Steel

All steel is purchased from Emmedue (Italy). The specification is as follows:

- Longitudinal steel wires: 2.5mm diameter
- Transversal steel wires: 2.5mm diameter
- Joint steel wire: 3.0mm diameter
- Steel wire yield: >600N/mm<sup>2</sup>
- Steel wire fracture: >680N/mm<sup>2</sup>

### 2.1.7 Ancillary Items

- Zinc-coated electrowelded wall tie connectors
- Pumped concrete
- Reinforcing bars
- Wall anchors
- Zinc-coated high tensile steel mesh
- Render
- Steel reinforcing bars
- Various fixing angles and brackets
- Joist hangers

## 2.2 DESIGN, STORAGE AND MARKING

The system is intended for use where Architect's drawings are available and satisfy the Building Regulations – the Architect and Engineer design team of the developer (the Client) are responsible for the drawings and overall building design to comply with the Building Regulations.

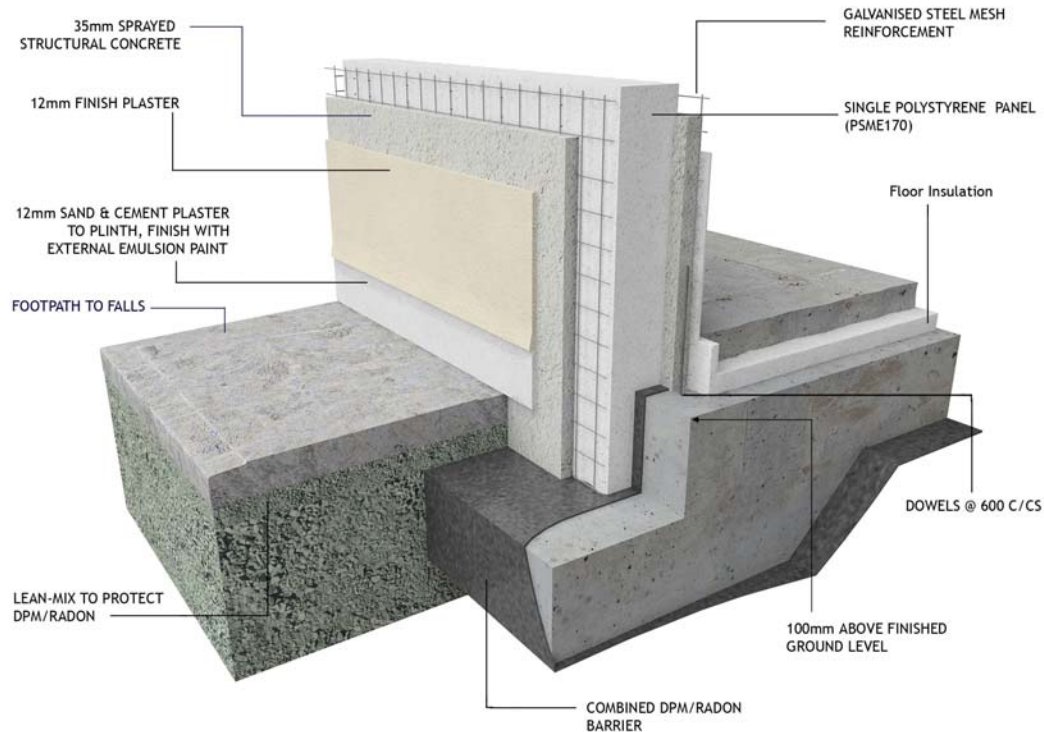

**Figure 3: Emmedue foundation detail**

Emmedue, through the use of a Chartered Engineer, are responsible for the structural design of the Emmedue M2 Building System for each project. The Engineer also liaises with the Engineer for the Developer and provides the necessary loading information for the design of the foundations.

### 2.2.1 Emmedue Panels & Floor Slabs Formwork

Emmedue panels should be stored on a clean, flat, hard surface area on the site. Panels should be stored on timber battens approximately 2m apart. Panels should be tied down to prevent uplift in windy conditions. Panels should not be stored for excessive periods of time out in the atmosphere.

### 2.2.2 Handling of Panels

Panels should be stored and transported on site in a manner that prevents damage, buckling or sprawling of the polystyrene or bending of the mesh reinforcement. Operatives should place the panels in position and tie them down to starter bars adjoining panels and slabs in the manner described in the operatives' manual. Panels should be properly braced to provide rigid temporary support to the walls during erection and concrete spraying and the placing of concrete in slabs. Propping of walls and slabs should be in accordance with the Emmedue Operations Manual.

## 2.3 INSTALLATION

Emmedue undertakes responsibility for the design and manufacture of the system. Site construction is undertaken using trained approved installers.

### 2.3.1 Foundations

Foundations are outside the scope of this Certificate and the Emmedue M2 system. However, typical foundation details (see Figure 4) incorporating DPCs/radon barriers should be used. Both single and double panel walls should have starter bars from either foundation or ground floor slab. All foundations should be designed by a chartered engineer with appropriate experience.

### 2.3.2 Assembly of Panels for Walls

Emmedue panels are anchored to the foundation or floor slab at ground level with dowel bars. In order to guarantee the continuity among the elements, the Emmedue panels are equipped on both sides with mesh overlap from panel to panel.

In order to achieve proper heat insulation, no gaps should be left between two adjacent panels during assembly. In addition, the panels should be placed in a perfectly vertical position and be well-aligned to minimise any eccentric loading on the structure. Typical details are shown in Figure 5 and 6.

During assembly, the main openings for doors, windows and balconies have to be considered as foreseen in the design. Typical details are shown in Figure 5 and 6.

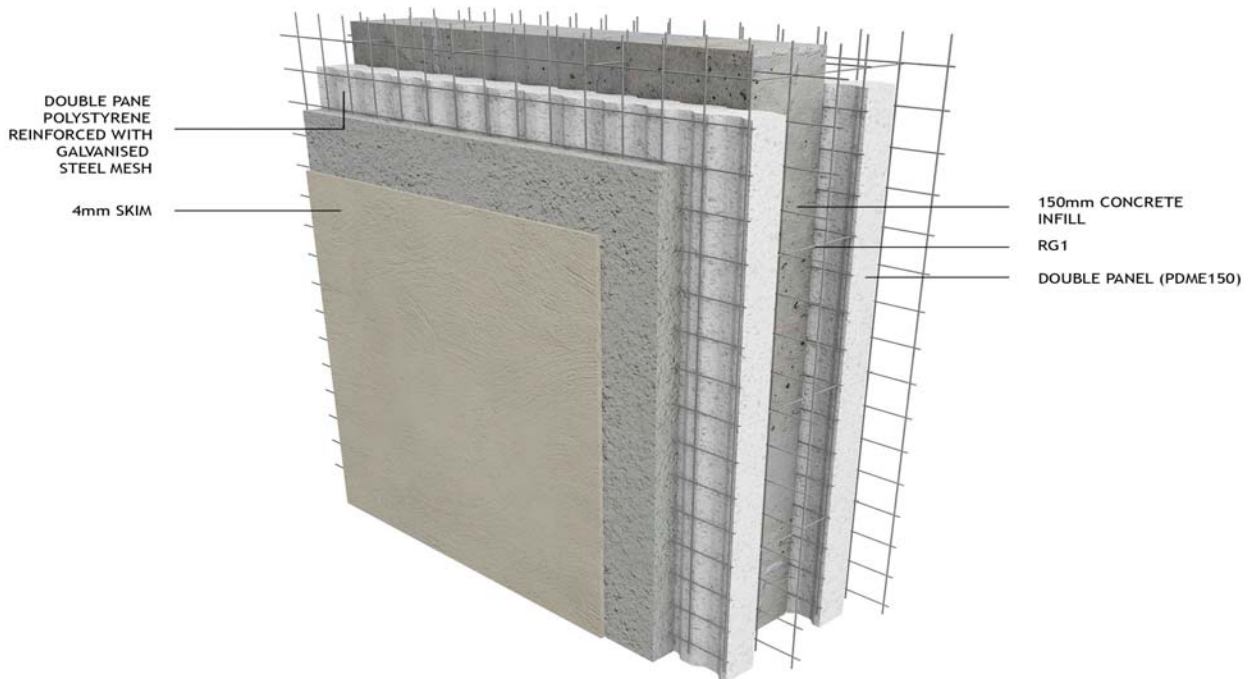

Figure 4: Emmedue double panel wall

Minor openings can be made after assembly by using cutting instruments such as circular saws, shears, knives and pliers. Care should be exercised in the cutting operation to minimise unnecessary damage to the polystyrene core.

### 2.3.3 Bracing Meshwork Installation

All internal walls are reinforced with angular mesh (RG1), which gives the structural mesh greater continuity.

The openings are braced using flat mesh (RG2) at 45° above and below corners of the opening. The window and door lintels, according to their length, and the window sills whose span is longer than 1.2m, can be integrated with additional reinforcements on both sides. To avoid cold bridging at door and window openings, a thermal break is provided between the internal and external concrete, as shown in Figure 5.

### 2.3.4 Installation of Emmedue Staircase

The stairs shall be designed to IS 326/Eurocode 2. Once the stairs panel is assembled and the reinforcement lattices are placed inside the panel internal channels, the latter are completed with gravel concrete (particle size <12mm) see Figure 7. The concrete may be cast in the panel ribs simultaneously with casting of the upper floor.

Subsequently, 25MPa sprayed concrete (50mm thick) is applied both on the lower face and on the sides of the flight, while on its upper side the flooring (marble, ceramic tiles etc.) can be directly laid on an adhesive layer. This panel enables the erection of stairs of classic dimensions only.

### 2.3.5 Separating Walls

All separating walls are to be constructed using the Emmedue M2 double panel wall. Care should be taken at the head of such walls to ensure the requirements of cl. 3.2.5 of Technical guidance document B of Irish Building Regulations 1997-2002 are adhered to.

### 2.3.6 Services

The laying of pipes for plumbing, electrical installation, heating services etc. takes place after the polystyrene panels have been erected and before the spraying of concrete takes place.

The polystyrene is melted using a hot air gun or similar tool. The electrical flexible pipes are placed under the meshwork. Where rigid pipes are placed within the polystyrene, the mesh may need to be cut. The area surrounding the cut should be restored by the addition of extra mesh connected to the meshwork of the panel. Copper pipes should be insulated from the meshwork with felt PVC or similar protection. No pipes greater than 50mm diameter should be installed in the polystyrene. Service pipes or ducts 100mm in diameter or more should be placed outside the structure or in ducts within the building.

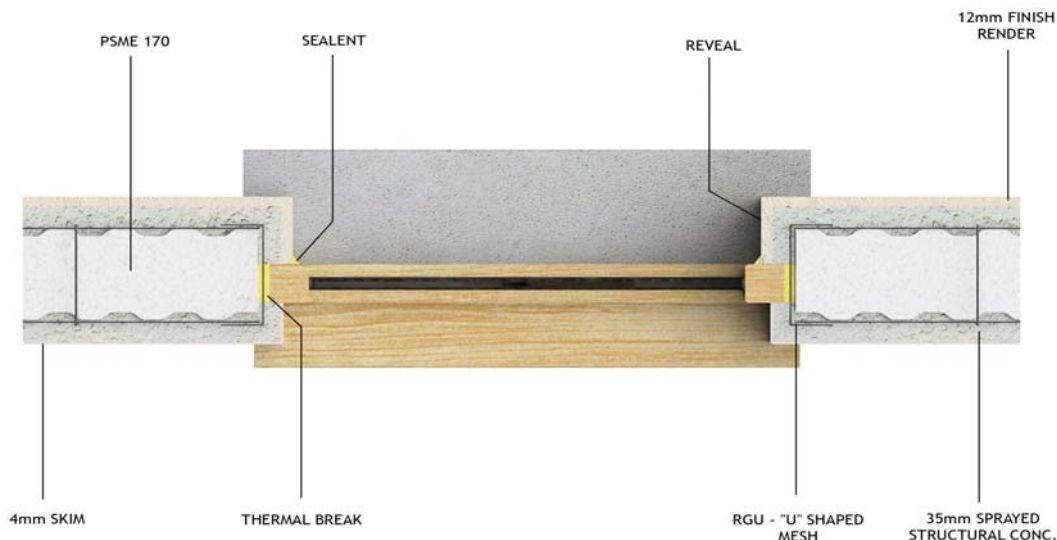
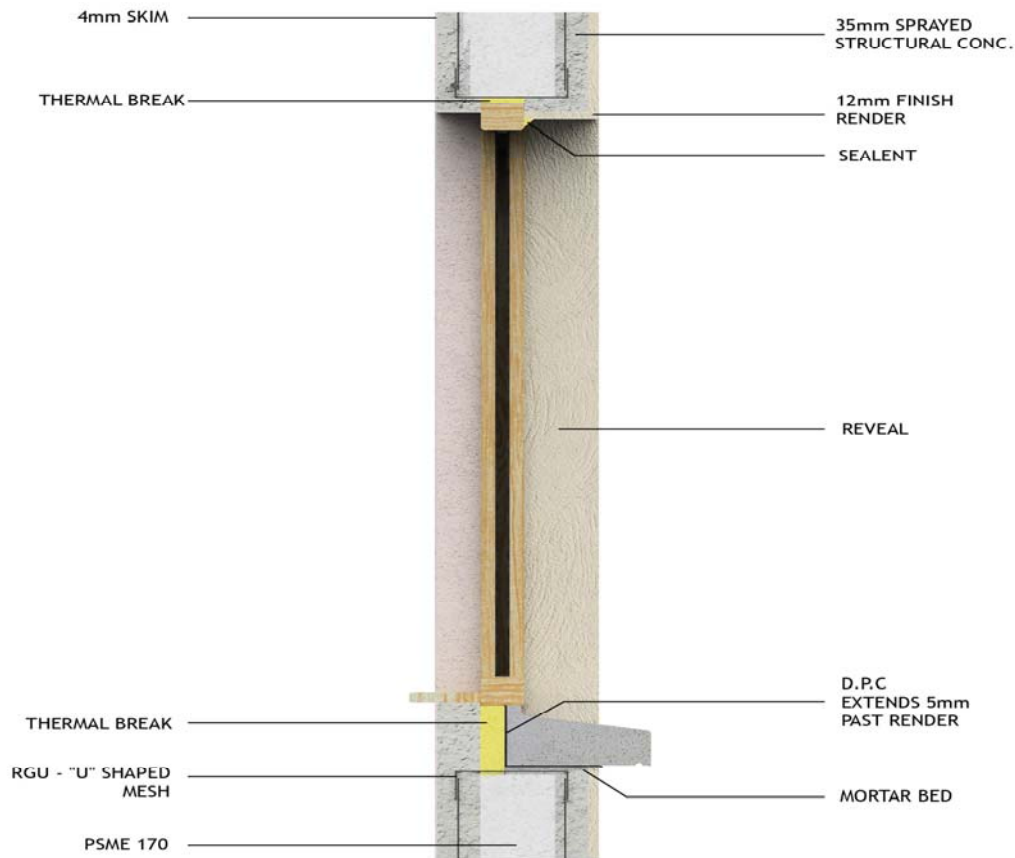

Figure 5a: Horizontal section through window opening on single panel wall



**Figure 5b: Vertical section through window opening single panel wall.**

The location of services should be as per the service drawing for the structure. Any alteration of change of location of services should be advised to Emmedue and noted in the service drawings for the structure.

### 2.3.7 Details of Balconies & Bay-Windows

The balconies can be executed by Emmedue ribbed floor panel with additional anchoring bars being anchored to the floor, designed in accordance with IS 326/Eurocode 2 (see Figure 8).

### 2.3.8 Sprayed Concrete

An approved concrete mix of 25MPa sprayed concrete should be used. The minimum cover to reinforcement is 30mm.

This operation will be carried out by trained installers, starting at the bottom and working up. Guide rails are used to ensure require thickness.

Emmedue have a QC testing schedule for concrete cubes and cores.

### 2.3.9 Finishing of the Floors

Place posts and boards at 1.1m intervals, slightly increasing the height of posts at the centre of the floor slab.

For the ribbed floors, the workers should take care to walk exclusively on the wooden bridge boards laying on the posts.

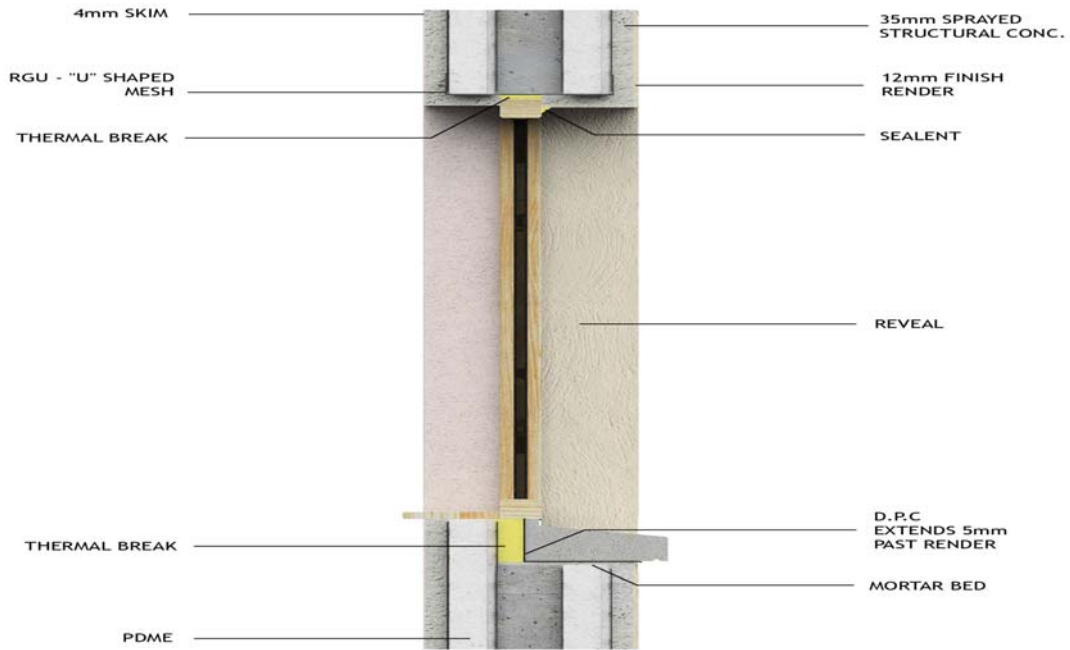

**Figure 6a: Vertical section through window opening on double panel wall.**

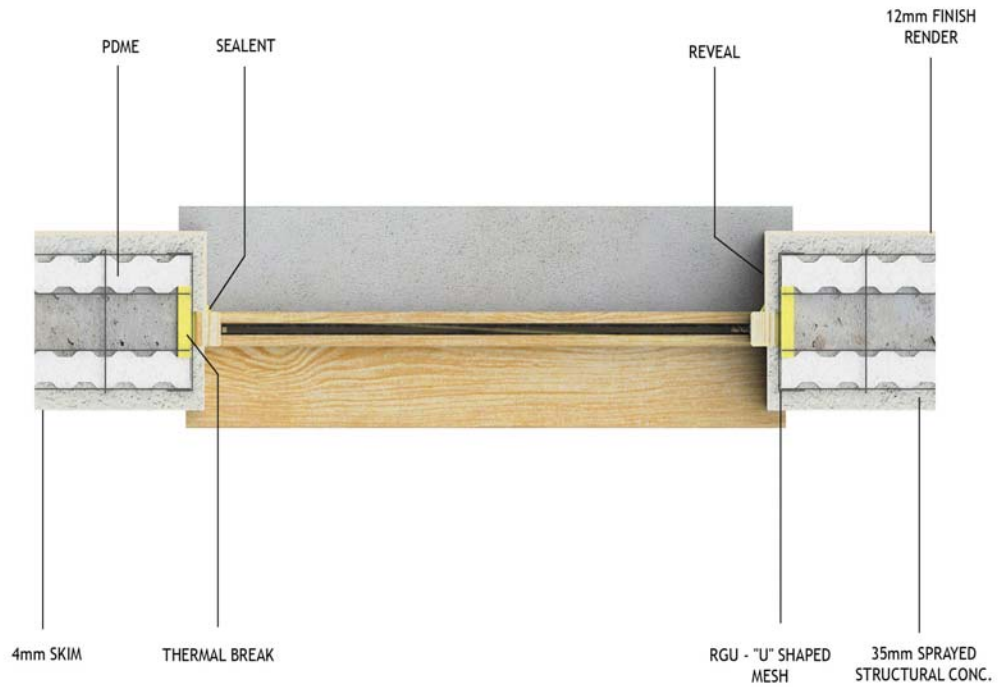

**Figure 6b: Horizontal section through window opening on double panel wall.**

The ring beam is constructed on each floor in accordance with M2 Building System Manual.

The designer should verify the floor panel reinforcement and, if required, should integrate it with additional reinforcement rods (to be substantiated by calculations) inside the panel ribs.

Once the floor slab concrete has reached the right cure degree, the posts should be removed starting from the centre outwards so as to gradually transfer the load to the floor slab.

### 2.3.10 Precautions

- Do not overload partition walls on one side only. Instead, spray the concrete onto both sides alternately.
- If a panel is cut during erection and its meshwork has no wire-crossing joints, panels should be joined with flat meshwork (min. width 225mm).

### 2.3.11 Fixing Objects to Walls

Lightweight objects: 25mm screws, pins or similar devices may be used.

Heavy objects (shelves, water-tanks etc.): Plastic pins with 45mm screws or similar devices are recommended

Very heavy objects: During erection, metal pins may be inserted in plaster pallets. Alternatively, a threaded pin fastened with epoxy resin may be used.

### 2.3.12 Walls Erected by Emmedue Double Panels

In buildings of up to four storeys, walls should be erected with Emmedue double panels that are properly reinforced. After panels have been fastened and aligned, the concrete can be carefully poured in layers and vibrated. The minimum concrete characteristic strength is 25MPa.

Once the in-situ concrete has gained sufficient strength, both sides of panels are coated with sprayed concrete in a similar way as the single panel. The minimum coating thickness for external panels is 35mm.

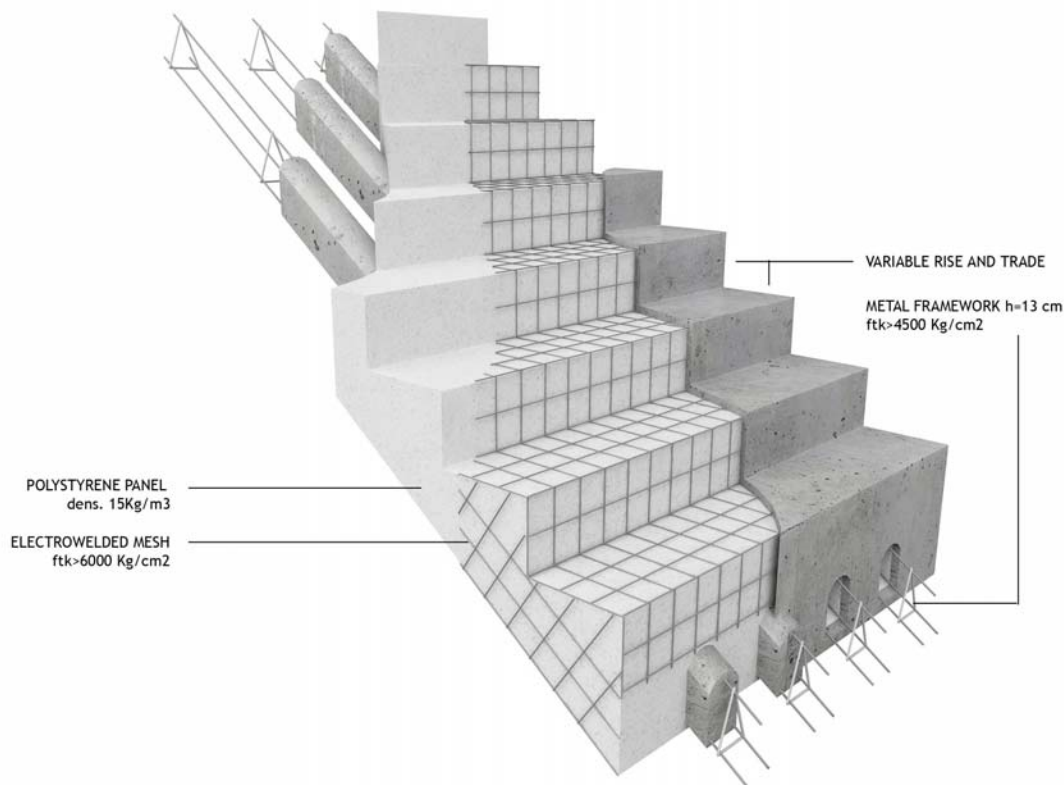

Figure 7: Details of staircase



### **3.1 STRENGTH & STABILITY**

#### **3.1.1 General**

Buildings constructed using the Emmedue M2 Building System shall be certified by a competent, chartered civil or structural engineer, with experience in design of buildings and structures incorporating the Emmedue M2 System, as being in accordance with Part A of the Building Regulations 1997 to 2002.

#### **3.1.2 Design Loads**

The loads to be taken into account at design stage should be determined in accordance with Part A of the Building Regulations 1997 to 2002.

#### **3.1.3 Impact Resistance**

The Emmedue M2 Building System provides a robust system that has a high resistance to hard and soft body impacts likely to be associated with normal use situations. The rendered wall is acceptable for all normal situations. This includes Category B in Table 2 of BS 8200:1985. Category A involves external walls of houses and public buildings in vandal prone areas – prone to vandalism and abnormally rough use and some damage could be expected to occur to the rendering in this type of location.

### **3.2 STRUCTURAL FIRE SAFETY**

#### **3.2.1 Internal fire spread (linings)**

The wall panels have a Class 0 rating in accordance with Building Regulations Technical Guidance Document B Appendix A Cl. A10.

#### **3.2.2 Internal fire spread (structure)**

When the building has been designed and installed in accordance with the requirements of this certificate, the walls are capable of withstanding the effects of fire for 60 minutes without loss of stability.

#### **3.2.3 External fire spread**

The wall panels are non-combustible, and have a Class 0 rating (see Cl 3.2.1). External panels can be designed to meet the requirements of Building Regulations Technical Guidance Document B Table 4.1.

### **3.3 WEATHERTIGHTNESS**

Externally the walls are protected by an approved render applied to the 35mm sprayed 25MPa fibre reinforced structural concrete. A DPC/radon barrier is installed at ground level to prevent rising damp. A DPC is also used around window sills, and a sealant is required around windows and door frames.

#### 4.1 BEHAVIOUR IN RELATION TO FIRE

The single and double panels have a Class 0 rating as per Table A6 of Part B of the Building Regulations 1997 to 2002.

For ceilings, 12mm plasterboard slab is fixed to the underside of the polystyrene to give a Class 0 rating. In the case of common stairwells (multiple occupancy apartment stairs), a minimum of 50mm sprayed concrete is applied to encase the polystyrene.

#### 4.2 THERMAL INSULATION AND U-VALUES

Assessments were carried out to verify that the requirements of Part L can be achieved using the Emmedue M2 Building System in typical designs.

#### 4.3 CONDENSATION

The system was subjected to a condensation risk analysis, which concluded that the risk of surface and interstitial condensation is minimal and that no vapour barrier is required.

#### 4.4 SOUND

Sound testing has been carried out on the party walls in houses and apartments (Figure 9), and also on the compartment floors in apartments. The sound assessment showed that the required sound attenuation values can be achieved using double panel construction for party walls with a minimum density of 415kgm<sup>2</sup> concrete. The floor construction tested for sound is shown in Figure 3.

#### 4.5 DURABILITY

Buildings based on the Emmedue M2 Building System, when constructed in accordance with the manufacturer's instructions and this Certificate, will have a minimum design life of at least 60 years in accordance with BS 7543: 1992 *Guide to Durability of Building Elements, products and components*.

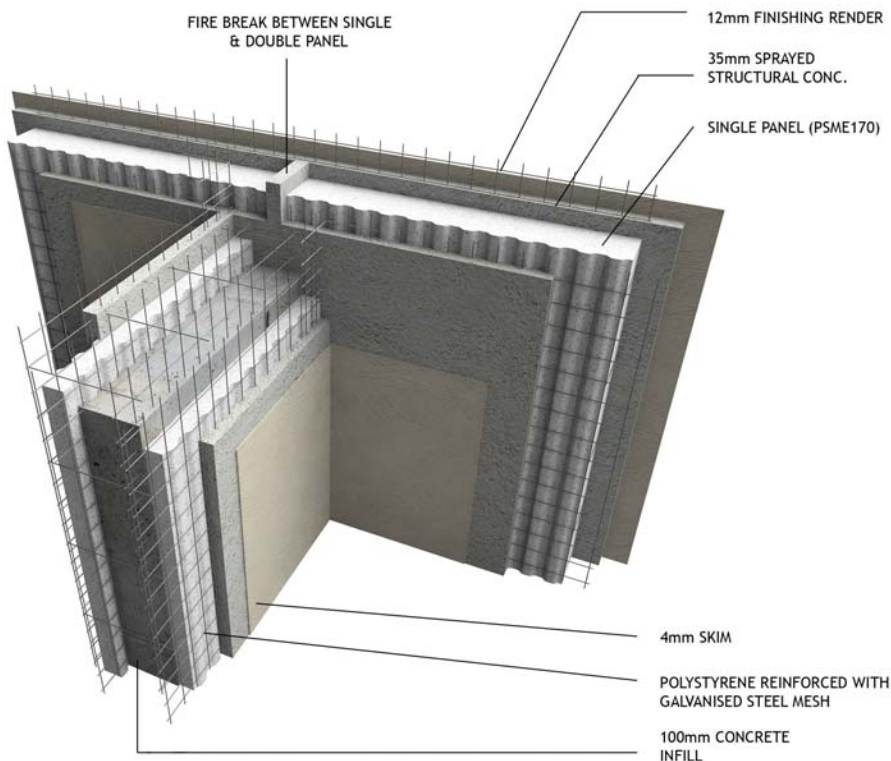

Figure 9: Detail at external/separating wall junction

#### **4.7 MAINTENANCE**

The rendering/concrete in the wall panels is maintenance free – however, the coloured rendering may discolour with time. The external sealants around window and door frames should be inspected periodically and replaced when necessary.

#### **4.8 PRACTICABILITY**

A Site Erection Manual and a Manual for Health & Safety are provided for each project, which incorporate the Emmedue M2 Building System.

The handing over involves a final inspection of the building and the completion of a Certificate of Compliance Report by the Chartered Engineer responsible for the project.

Erection of the Emmedue M2 Building System must be by trained installers.

#### **4.9 TESTS AND ASSESSMENTS WERE CARRIED OUT TO DETERMINE THE FOLLOWING:**

- Structural strength and stability
- Behaviour in fire
- Resistance to airborne and impact sound transmission
- Thermal transmittance values
- Condensation risks for external walls
- Impact resistance for external walls
- Site erection controls

#### **4.10 OTHER INVESTIGATIONS**

- The manufacturing process was examined including the methods adopted for quality control, and details were obtained of the quality and composition of the materials used
- Site visits were conducted to assess the practicability of installation
- Bought-in components were assessed for suitability for use
- No failures of the product in use have been reported to the IAB.

- 5.1** National Standards Authority of Ireland ("NSAI") following consultation with the Irish Agrément Board ("IAB") has assessed the performance and method of installation of the product/process and the quality of the materials used in its manufacture and certifies the product/process to be fit for the use for which it is certified provided that it is manufactured, installed, used and maintained in accordance with the descriptions and specifications set out in this Certificate and in accordance with the manufacturer's instructions and usual trade practice. This Certificate shall remain valid for five years from date of issue so long as:
- (a) the specification of the product is unchanged.
  - (b) the Building Regulations 1997 to 2002 and any other regulation or standard applicable to the product/process, its use or installation remains unchanged.
  - (c) the product continues to be assessed for the quality of its manufacture and marking by NSAI.
  - (d) no new information becomes available which in the opinion of the NSAI, would preclude the granting of the Certificate.
  - (e) the product or process continues to be manufactured, installed, used and maintained in accordance with the description, specifications and safety recommendations set out in this certificate.
  - (f) the registration and/or surveillance fees due to IAB are paid.
- 5.2** The IAB mark and certification number may only be used on or in relation to product/processes in respect of which a valid Certificate exists. If the Certificate becomes invalid the Certificate holder must not use the IAB mark and certification number, and must remove them from the products already marked.
- 5.3** In granting Certification, the NSAI makes no representation as to;
- (a) the absence or presence of patent rights subsisting in the product/process; or
  - (b) the legal right of the Certificate holder to market, install or maintain the product/process; or
  - (c) whether individual products have been manufactured or installed by the Certificate holder in accordance with the descriptions and specifications set out in this Certificate.
- 5.4** This Certificate does not comprise installation instructions and does not replace the manufacturer's directions or any professional or trade advice relating to use and installation which may be appropriate.
- 5.5** Any recommendations contained in this Certificate relating to the safe use of the certified product/process are preconditions to the validity of the Certificate. However the NSAI does not certify that the manufacture or installation of the certified product or process in accordance with the descriptions and specifications set out in this Certificate will satisfy the requirements of the Safety, Health and Welfare at Work Act, 1989, or of any other current or future common law duty of care owed by the manufacturer or by the Certificate holder.
- 5.6** The NSAI is not responsible to any person or body for loss or damage including personal injury arising as a direct or indirect result of the use of this product or process.
- 5.7** Where reference is made in this Certificate to any Act of the Oireachtas, Regulation made thereunder, Statutory Instrument, Code of Practice, National Standards, manufacturer's instructions, or similar publication, it shall be construed as reference to such publication in the form in which it is in force at the date of this Certification.

## The Irish Agrément Board

This Certificate No. **06/0241** is accordingly granted by the NSAI to **Emmedue Ltd.** on behalf of The Irish Agrément Board.

Date of Issue: **February 2006**

Signed

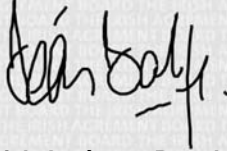

**Manager Irish Agrément Board**

Readers may check that the status of this Certificate has not changed by contacting the Irish Agrément Board, NSAI, Glasnevin, Dublin 9, Ireland. Telephone: (01) 807 3800. Fax: (01) 807 3842. [www.n sai.ie](http://www.n sai.ie)