



This product is preferable to similar connectors because of a) easier installation, b) higher loads, c) lower installed cost, or a combination of these features.

HDC product line eliminates eccentricity. Installs with SDS screws (included) to reduce slip and maintain post capacity.

MATERIAL: 10 gauge strap. **FINISH:** Galvanized strap, aluminum base.

INSTALLATION: • Use all specified fasteners. See General Notes.

• Install on concrete.

- Sized for 2-2x, 4x and 2-2x6 members in two load capacities center HDC on post.
- Concentric to eliminate bending on the stud.

• Install Simpson's code-recognized SDS[®] 1/4x2 1/2 wood screws, which are provided with the holdown. (Lag screws will not achieve the same load.)

- Slot in the seat allows for 3/8" of adjustment perpendicular to plate.

(Standard cut washer required.)

- Witness slot in the base to inspect the nut.
- Maximum anchor bolt height above concrete is 2 1/2".
- **To tie double 2x members together, the designer must determine the fasteners required to bind members to act as one unit without splitting the wood.**

• Aluminum standoff cannot be in contact with pressure treated wood.

CODES: See page 10 for Code Listing Key Chart.

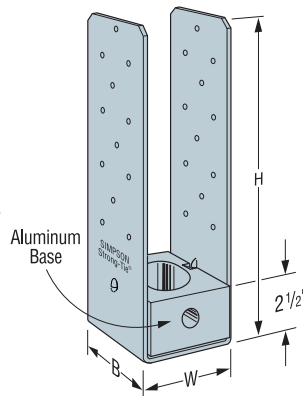

HDC10

US Patent 6,513,290

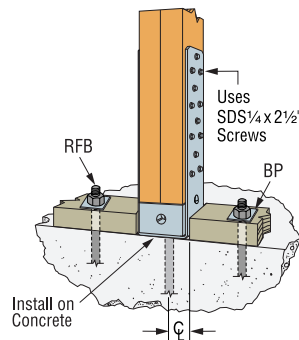

Typical HDC Installation with 2-2x4 studs (Similar with 2-2x6 studs)

Model No.	Post Size	W	H	B	ϕ	Anchor Bolt	Number of SDS 1/4x2 1/2	Avg UII	Allowable Tension DF/SP (133)	Allowable Tension HF/SPF (133)	Concrete Bearing ⁷ @ 2500 psi	Holdown Deflection at Highest Allowable Design Load	Code Ref.
HDC5/22-SDS2.5	2-2x4	3 1/8	9 3/8	3	1 1/16	5/8	12	23377	4870	4215	7460	.032	45
HDC5/4-SDS2.5	4x4	3 1/8	9 3/8	3	1 13/16	5/8	12	23377	4870	4215	9060	.032	
HDC10/22-SDS2.5	2-2x4	3 1/8	14 3/8	3	1 1/16	7/8	24	29867	9665	8425	7460	.075	
HDC10/4-SDS2.5	4x4	3 1/8	14 3/8	3	1 13/16	7/8	24	29867	9665	8425	9060	.075	

For holdowns, per ASTM test standards, anchor bolt nuts should be finger-tight plus 1/3 to 1/2 turn with a wrench.

1. The designer must specify anchor bolt type, length and embedment. See the SSTB Anchor Bolts.
2. See page 16 and 22 for retrofit anchor bolt.
3. Loads are based on static tests on wood studs, limited by the lowest of 0.125" deflection, ultimate divided by 3, or the wood screw value.
4. Deflection at Highest Allowable Design Load:
The deflection of a holdown measured between

the anchor bolt and the strap portion of the holdown when loaded to the highest allowable load listed in the catalog table. This movement is strictly due to the holdown deformation under a static load test conducted on a steel jig.

5. SDS screws install best with a low speed 1/2" drill with a 3/8" hex head driver.
6. **The HDC's will be limited by wood compression capacity if installed on a plate.**
HDC5/22 and HDC10/22 will achieve an allowable load of 4005 lb. on a DFL plate. HDC5/4 and HDC10/4 will achieve an allowable load of 4940 lb. on a DFL plate, which does not take deflection into account.

7. Higher values may be obtained when HDC is not placed at an edge or with f'c concrete strength > 2500 psi.