

The LTA1 develops high uplift and lateral loads at a minimum heel height. Great in areas where a strap over the heel is not required. The side tabs act as a locator in the block and the four embedded hooks provide for a positive bond in the concrete.

MATERIAL: 18 gauge

FINISH: Galvanized

INSTALLATION: • Use all specified fasteners. See General Notes.

CODES: See page 10 for Code Listing Key Chart.

Model No.	Fasteners	Doug-Fir Larch/So. Pine Allowable Loads			Spruce-Pine-Fir Allowable Loads			Code Ref.
		Uplift		Lateral (133/160)	Uplift		Lateral (133/160)	
		133/160	F ₁	F ₂	133/160	F ₁	F ₂	
LTA1	12-10dx1½	1420	485	1425	1220	415	1225	160

1. Allowable loads are based on a minimum of 2500 psi grout strength with one #5 horizontal rebar in the shear cone.
2. Uplift loads have been increased 33% and 60% for wind loading with no further increase allowed; reduce where other loads govern.

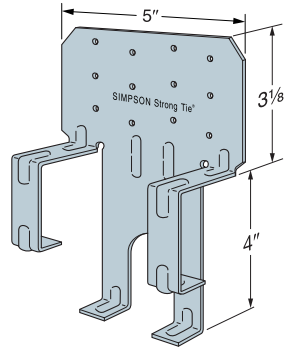

LTA1
U.S. Patent 6,560,943

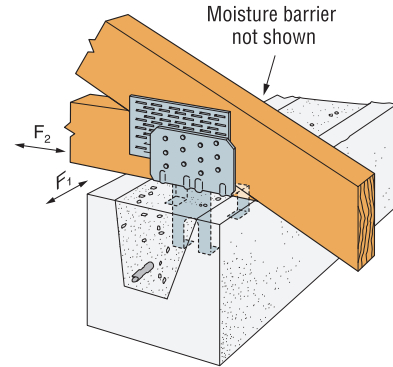

Typical LTA1 Installation