

1-CORNER DETAIL

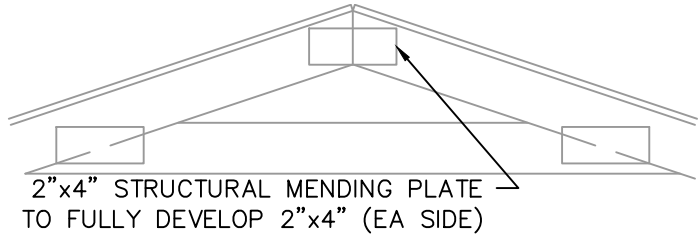

2-TRUSS SPLICE DETAIL

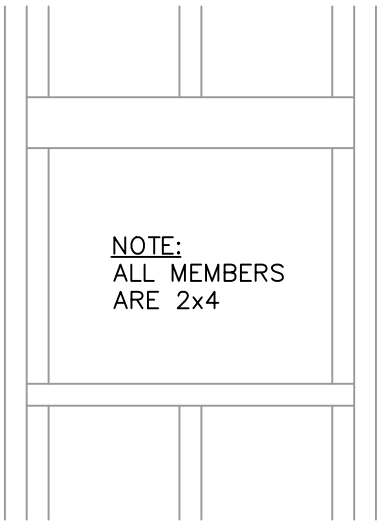

NOTE:
ALL MEMBERS
ARE 2x4

3-TYP WINDOW FRAMING

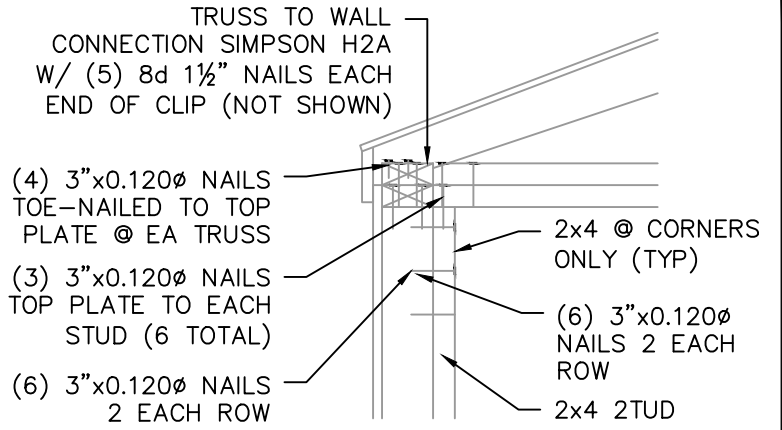

NOTE: INSTALL H2 5A PER MANUFACTURES
RECOMMENDATIONS

4-CORNER & WALL DETAIL

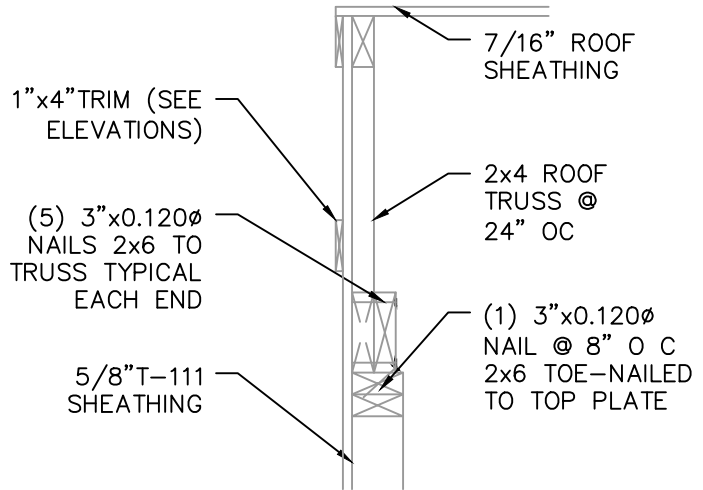

5-END WALL DETAIL

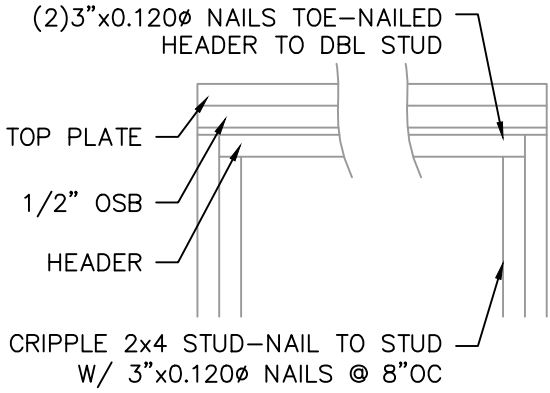

6-TYP DOOR FRAMING

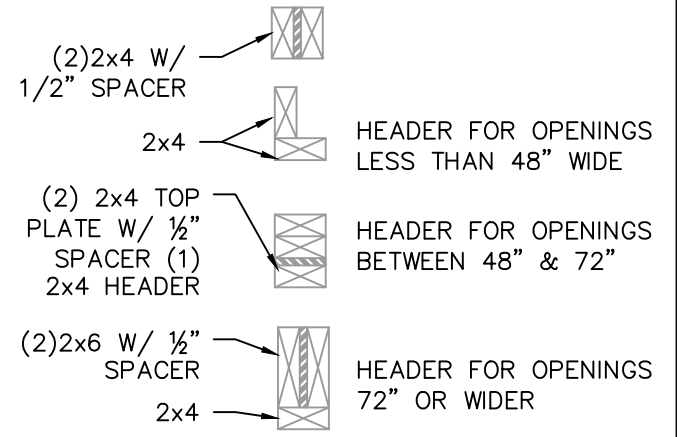

NOTE: FOR 12' HIGH OR GREATER SIDEWALLS,
A 48" MAX OPENING IS ALLOWED



APEX BUILDERS AND ASSOCIATES
BUILDERS & ASSOCIATES
504-858-6544

DRAWN BY: TNT SCALE: NTS DATE: 02-14-2022

SHEET TITLE: BUILD DETAIL 1

DRAWING NUMBER: **S-109**



Chief Engineer: Brian Mistich, PE
554 Old Spanish Trail
Slidell, LA 70458
www.dammonengineering.com
info@dammonengineering.com
PHONE: 985-649-5832