

MATERIAL: CC3¼, CC44, CC46, CC48, CC64, CC66, CC68, CC6-7½—7 gauge; all others—3 gauge

FINISH: Simpson gray paint; may be ordered HDG; CCO—no finish.

INSTALLATION: • Use all specified fasteners. See General Notes.

- Bolt holes shall be a minimum of ¼" to a maximum of ¼" larger than the bolt diameter (per 2001 NDS, section 11.1.2).

OPTIONS: • Straps may be rotated 90° where $W_1 \geq W_2$ (see illustration).

- For special, custom, or rough cut lumber sizes, provide dimensions. An optional W_2 dimension may be specified with any column size given (note that the W_2 dimension on straps rotated 90° is limited by the W_1 dimension).
- Column caps with W_1 , L , H_1 , and hole schedules different from the table may be special ordered. Provide a drawing to ensure accuracy.

CCO—Column cap only may be ordered for field-welding to pipe or other columns. **No loads apply. CCO dimensions are the same as CC.**

CCOB—Any two CCOs may be specified for back-to-back welding to create a cross beam connector. Use the table loads; the load is no greater than the lesser element employed.

CCC/CCT—Cross Column Cap/T Column Cap. 7 gauge stirrups may be welded to column cap sides. Uplift loads do not apply to side stirrups.

The following criteria apply:

1. The side stirrup maximum allowable download cannot exceed 40% of the download in the table for the unmodified product, and cannot exceed 10,665 lbs. The sum of the loads cannot exceed the table load. The column width in the direction of the beam width must be the same as the beam width: W_1 .
2. Specify the stirrup height from the top of the cap. The minimum H_2/H_3 for the stirrup is 6½" (3½" for 44s).
3. The L dimension may vary depending on W_3 or W_4 .

Ordering examples: A CCC66 with $W_3 = 5½"$, H_2 and $H_3 = 6½"$ is a CC66 column cap with 5½" beams on each side with all beam seats flush.

CODES: See page 10 for Code Listing Key Chart.

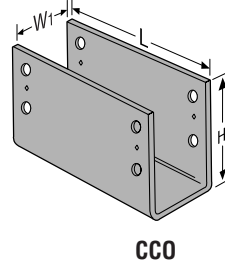
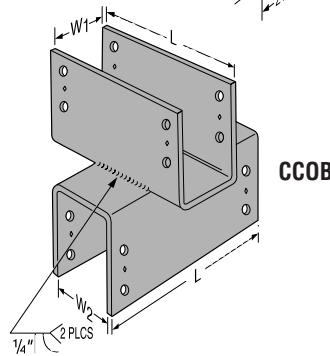
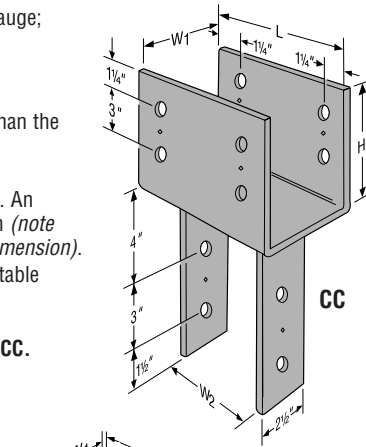

Model No.	Dimensions				Fasteners				Allowable Loads			Code Ref.
	W ₁	W ₂	L	H ₁	Beam		Post		Uplift		Down	
					Qty	Dia	Qty	Dia	(133)	(160)		
CC3¼-4	3¼	3¾	11	6½	4	⅝	2	⅝	3035	3640	19250	
CC3¼-6	3¼	5½	11	6½	4	⅝	2	⅝	3035	3640	19250	
CC44	3¾	3¾	7	4	2	⅝	2	⅝	1220	1465	15310	
CC46	3¾	5½	11	6½	4	⅝	2	⅝	2330	2800	24060	
CC48	3¾	7½	11	6½	4	⅝	2	⅝	2330	2800	24060	
CC5¼-4	5¼	3¾	13	8	4	¾	2	¾	6305	7530	37310	
CC5¼-6	5¼	5½	13	8	4	¾	2	¾	6275	7530	37310	
CC5¼-8	5¼	7½	13	8	4	¾	2	¾	6275	7530	37310	
CC64	5½	3¾	11	6½	4	⅝	2	⅝	3365	4040	37810	
CC66	5½	5½	11	6½	4	⅝	2	⅝	3365	4040	37810	
CC68	5½	7½	11	6½	4	⅝	2	⅝	3365	4040	37810	
CC6-7½	5½	7½	11	6½	4	⅝	2	⅝	3365	4040	37810	
CC7½-4	7½	3¾	13	8	4	¾	2	¾	6260	7510	68250	20, 80
CC7½-6	7½	5½	13	8	4	¾	2	¾	6320	7585	68250	
CC7½-7½	7½	7½	13	8	4	¾	2	¾	6320	7585	68250	
NEW CC7½-8	7½	7½	13	8	4	¾	2	¾	6320	7585	68250	
CC74	6¾	3¾	13	8	4	¾	2	¾	6270	7525	49140	
CC76	6¾	5½	13	8	4	¾	2	¾	6270	7525	49140	
CC77	6¾	6¾	13	8	4	¾	2	¾	6270	7525	49140	
CC78	6¾	7½	13	8	4	¾	2	¾	6270	7525	49140	
CC86	7½	5½	13	8	4	¾	2	¾	6200	7440	54600	
CC88	7½	7½	13	8	4	¾	2	¾	6200	7440	54600	
CC96	8¾	5½	13	8	4	¾	2	¾	6260	7515	63700	
CC98	8¾	7½	13	8	4	¾	2	¾	6260	7515	63700	
CC106	9½	5½	13	8	4	¾	2	¾	6260	7515	69160	

1. Post sides are assumed to lie in the same vertical plane as the beam sides.
2. Loads may not be increased for short-term loading.
3. Downloads are determined using F_{cL} equal to: 560 psi for glulam sizes and CC86, CC88 and CC106; 750 psi for 7½" size; 625 psi for all others; reduce where end bearing value of post, l/d of post, or other criteria are limiting.

4. Uplift loads have been increased 33% and 60% for earthquake or wind loading; reduce where other loads govern. **Uplift loads are limited by the beam shear capacity per 2001 NDS except CC76, CC78, and CC96 through CC106.**
5. Spliced conditions must be detailed by the specifier to transfer tension loads between spliced members by means other than the column cap.
6. Uplift loads do not apply to splice conditions.

There are cost-effective alternatives for replacing column caps by using a combination of connectors. Here are some examples. Designer must specify the options required.

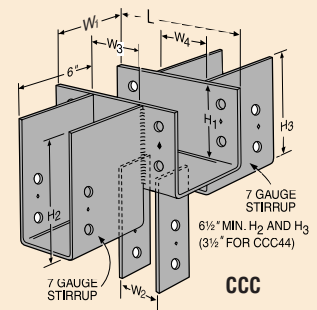

Instead of the column cap, consider this connector combination.

NOTE: The side cap will be welded flush with the top of the main cap.

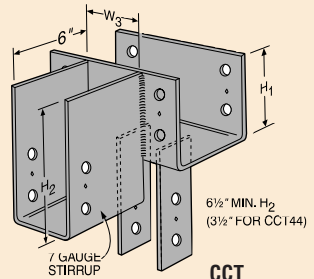
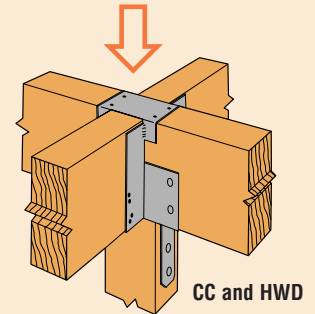

Instead of the column cap, consider this connector combination.

NOTE: The side cap will be welded flush with the top of the main cap.

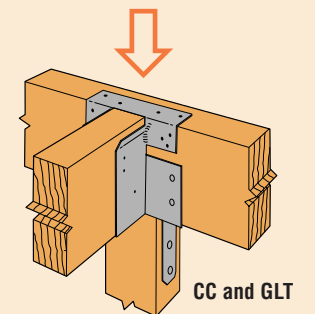

Order each connector separately. Specify all side stirrup widths and heights

For more information, request Form T-CC and the Product Worksheet.

Side stirrups are available in different depths.

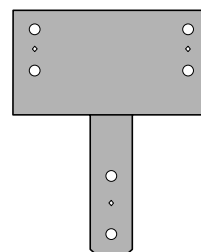

Optional CC with straps rotated 90°