

FACE MOUNT HANGERS HUS/HHUS/HGUS

DOUBLE SHEAR
SCL HANGERS

See Hanger tables on pages 72 to 76. See Hanger Options on page 158 for hanger modifications, which may result in reduced loads.

These hangers have the highest loads of any face mount hangers!

All hangers in this series have double shear nailing. This patented innovation distributes the load through two points on each joist nail for greater strength. It also allows the use of fewer nails, faster installation, and the use of common nails for all connections. *(Do not bend or remove tabs)*

MATERIAL: See tables, pages 72 to 76.

FINISH: Galvanized. Some products available in stainless steel or Z-MAX; see Corrosion-Resistance, page 5.

INSTALLATION • Use all specified fasteners. See General Notes.

- **Do not use double shear hangers with I-joists.**
- Nails must be driven at an angle through the joist or truss into the header to achieve the table loads.
- Not designed for welded or nailer applications.
- 16d sinkers (9 gauge x 3¼") may be used where 10d commons are specified with no reduction in load. Where 16d commons are specified, 10d commons or 16d sinkers (9 gauge x 3¼") may be used at 0.84 of the table load.
- With 3x carrying members, use 16d x 2½" nails into the header and 16d commons into the joist with no load reduction. With 2x carrying members, use 10d x 1½" nails into the header and 10d commons into the joist, and reduce the load to 0.64 of the table value.

OPTIONS: • HUS hangers available with the header flanges turned in for 3½" wide joist only, with no load reduction. See HUSC Concealed Flange illustration.

- Concealed flanges are not available for HGUS and HHUS.
- See Hanger Options, page 158, for sloped and/or skewed HHUS models.
- Other sizes available; consult your Simpson representative.

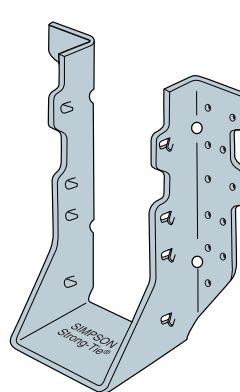

HUS28

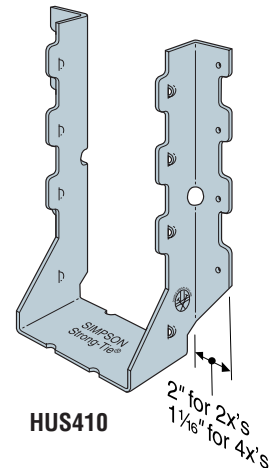

HUS410

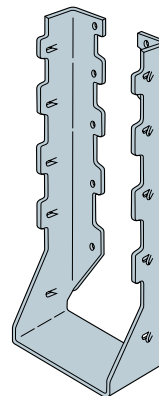

HUSC
Concealed Flanges
(not available for
HHUS, HGUS
and HUS1.81/10)

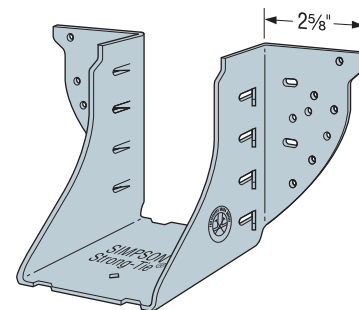

HGUS46

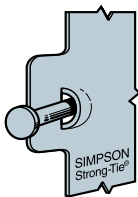

Dome Double Shear
Nailing prevents tabs
breaking off (available
on some models)

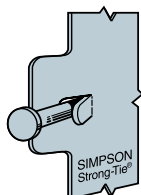

Double Shear
Nailing Side View
Do not bend tab back

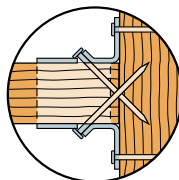

Double Shear
Nailing Top View