

TOP FLANGE HANGERS W/WP/WPU/WM/WMU/HW/HWU

I-JOIST AND STRUCTURAL COMPOSITE LUMBER HANGERS

The W, WP, WPU, HWU and HW series purlin hangers offer the greatest design flexibility and versatility. WMs are designed for use on standard 8" grouted masonry block wall construction.

MATERIAL: See tables on pages 83 to 95; W, WI—12 ga. top flange and stirrup;
WM, WMI, WMU—12 ga. top flange and stirrup; WPU, WP—7 ga. top flange, 12 ga. stirrup;
HW, HWI—3 ga. top flange, 11 ga. stirrup; HWU—3 ga. top flange, 10 ga. stirrup.

FINISH: Simpson gray paint; hot-dipped galvanized available; specify HDG.

ALLOWABLE LOADS: For hanger heights exceeding the joist height, the allowable load is 0.50 of the table load.

INSTALLATION: • Use all specified fasteners. WM—two 16d duplex nails must be installed into the top flange and embedded into the grouted wall. Verify that the header can take the required fasteners specified in the table.

- Hangers may be welded to steel headers with 1/8" for W, WI, 3/16" for WP, WPI, and 1/4" for HW, HWI, by 1 1/2" fillet welds located at each end of the top flange. Weld-on applications produce maximum allowable load listed. Uplift loads do not apply to this application.
- Hangers can support multi-ply carried members; the individual members must be secured together to work as a single unit before installation into the hanger.
- Embed WM into block with a minimum of one course above and one course below the top flange with one #5 vertical rebar minimum 24" long in each cell. **Minimum grout strength is 2000 psi.**
- Web stiffeners are required for standard joist nailing configuration with this hanger.

OPTIONS: • Specify alternate nailing pattern when web stiffeners are not being used (up to 16" in depth). Add X ANP after model number for nailing into the flange, available for 90° applications only. Uplift loads do not apply to this application.

• See Hanger Options, page 158 for hanger modifications and associated load reductions.

CODES: See page 10 for Code Listing Key Chart.

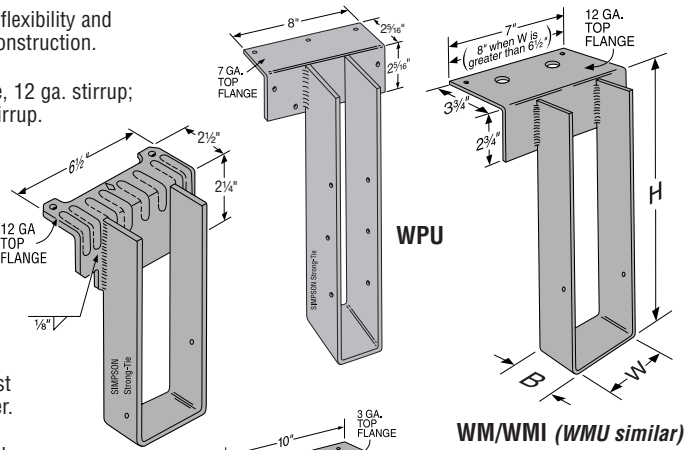

W/WI

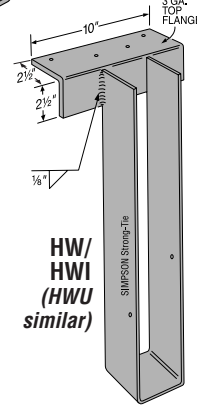

HW/HWI (HWU similar)

Some model configurations may differ from those shown. Contact factory for details.

| Model | Nailer | Top Flange Nailing | Allowable Loads | | |
|--------|--------|--------------------|-----------------|------|------|
| | | | DF/SP | SPF | LSL |
| W/WI | 2x | 2-10dx1 1/2 | 1600 | 1600 | — |
| | 3x | 2-16dx2 1/2 | 1765 | 1740 | — |
| | 2-2x | 2-10d | 1665 | 1665 | — |
| | 4x | 2-10d | 2200 | 2200 | — |
| WP/WPI | 2x | 2-10dx1 1/2 | 2525 | 2500 | 3375 |
| | 3x | 2-16dx2 1/2 | 3000 | 2510 | — |
| | 2-2x | 2-10d | 3255 | 3255 | — |
| | 4x | 2-10d | 3255 | 3255 | — |
| HW/HWI | 4x | 4-16d | 5285 | — | — |
| HWU | 2-2x | 8-16dx2 1/2 | 5630 | — | — |

NAILER TABLE

The table indicates the maximum allowable loads for W, WP and HW hangers used on wood nailers. Nailers are wood members attached to the top of a steel I-beam, concrete or masonry wall. This table also applies to sloped-seat hangers.

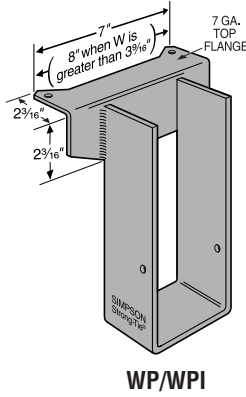

WP/WPI

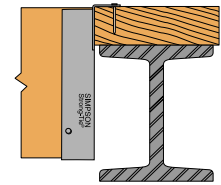

Correct Nailer Attachment

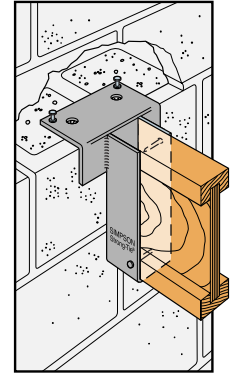

Typical WM Installation with Alternate Nailing Pattern (ANP)

W SERIES WITH VARIOUS HEADER APPLICATIONS

| Model | Joist | | Fasteners | | | Allowable Loads Header Type | | | | | | | Code Ref. | |
|----------|----------------|------------------|-------------|---------------------|-------------|-----------------------------|------------------------|------|------|-------|------|-----------------------------|-----------|--------------------------|
| | Width | Depth | Top | Face | Joist | Uplift (133 & 160) | DF/SP LVL ⁴ | PSL | LSL | DF/SP | SPF | DF/SCL I-Joist ⁵ | | Masonry |
| WI | 1 1/2 to 4 | 3 1/2 to 30 | 2-10dx1 1/2 | — | 2-10dx1 1/2 | — | 1635 | 1740 | — | 1600 | 1415 | — | — | 170 |
| | 1 1/2 to 4 | 3 1/2 to 30 | 2-10d | — | 2-10dx1 1/2 | — | 2150 | 2020 | — | 2200 | 1435 | — | — | 26, 83 |
| | 1 1/2 to 4 | 3 1/2 to 30 | 2-16d | — | 2-10dx1 1/2 | — | 2335 | 1950 | 2335 | 1765 | 1435 | — | — | 1, 84 |
| WMI | 1 1/2 to 4 | 3 1/2 to 30 | 2-16d DPLX | — | 2-10dx1 1/2 | — | — | — | — | — | — | — | 4175 | 1, 84 |
| | 1 1/2 to 7 1/2 | 9 to 18 | 2-16d DPLX | 4-1/4x1 1/4" Titens | 6-10dx1 1/2 | 660 | — | — | — | — | — | — | 4175 | 170 |
| | 1 1/2 to 7 1/2 | 18 1/2 to 22 1/2 | 2-16d DPLX | 4-1/4x1 1/4" Titens | 6-10dx1 1/2 | 660 | — | — | — | — | — | — | 4175 | 170 |
| WMU | 1 1/2 to 7 1/2 | 23 to 28 | 2-16d DPLX | 4-1/4x1 1/4" Titens | 6-10dx1 1/2 | 625 | — | — | — | — | — | — | 4175 | 170 |
| | 1 1/2 to 7 1/8 | 3 1/2 to 30 | 3-10dx1 1/2 | — | 2-10dx1 1/2 | — | 2865 | 3250 | — | 2500 | 2000 | 2030 | — | 26, 83 |
| | 1 1/2 to 7 1/8 | 3 1/2 to 30 | 3-10d | — | 2-10dx1 1/2 | — | 2525 | 3250 | 3650 | 3255 | 2525 | — | — | 26, 83 |
| WP/WPI | 1 1/2 to 7 1/8 | 3 1/2 to 30 | 3-16d | — | 2-10dx1 1/2 | — | 3635 | 3320 | 3650 | 3255 | 2600 | — | — | (widths greater than 2") |
| | 1 1/2 to 7 1/8 | 3 1/2 to 30 | 3-16d | 4-16d | 6-10dx1 1/2 | 775 | 4700 | 4880 | 3650 | 4165 | 4165 | — | — | 26 |
| | 1 1/2 to 7 1/8 | 3 1/2 to 30 | 3-16d | 4-16d | 6-10dx1 1/2 | 485 | 4700 | 4880 | 3650 | 4165 | 4165 | — | — | (widths up to 3 3/4") |
| WPU/WNPU | 1 3/4 to 5 1/2 | 7 1/4 to 18 | 3-16d | 4-16d | 6-10dx1 1/2 | 315 | 4700 | 4880 | 3650 | 4165 | 4165 | — | — | 26 |
| | 1 3/4 to 5 1/2 | 18 1/2 to 22 1/2 | 3-16d | 4-16d | 6-10dx1 1/2 | 485 | 4700 | 4880 | 3650 | 4165 | 4165 | — | — | 26 |
| | 1 3/4 to 5 1/2 | 23 to 28 | 3-16d | 4-16d | 6-10dx1 1/2 | 315 | 4700 | 4880 | 3650 | 4165 | 4165 | — | — | 26 |
| HWI | 1 1/2 to 7 1/2 | 3 1/2 to 32 | 4-10d | — | 2-10dx1 1/2 | — | 3100 | 4000 | — | 5285 | 3100 | — | — | 26, 83 |
| | 1 1/2 to 7 1/2 | 3 1/2 to 32 | 4-16d | — | 2-10dx1 1/2 | — | 5100 | 4000 | 4500 | 5285 | 3665 | — | — | 26, 83 |
| HWU | 1 3/4 to 3 1/2 | 9 to 18 | 4-16d | 4-16d | 6-10dx1 1/2 | 810 | 6335 | 5500 | 5535 | 6335 | 5415 | — | — | 26 |
| | 1 3/4 to 3 1/2 | 18 1/2 to 22 1/2 | 4-16d | 4-16d | 6-10dx1 1/2 | 765 | 6335 | 5500 | 5535 | 6335 | 5415 | — | — | 26 |
| | 1 3/4 to 3 1/2 | 23 to 28 | 4-16d | 4-16d | 6-10dx1 1/2 | 635 | 6335 | 5500 | 5535 | 6335 | 5415 | — | — | 26 |
| | 1 3/4 to 3 1/2 | 28 1/2 to 32 | 4-16d | 4-16d | 8-10dx1 1/2 | 1005 | 6335 | 5500 | 5535 | 6335 | 5415 | — | — | 26 |
| | 4 1/2 to 7 | 9 to 18 | 4-16d | 4-16d | 6-10dx1 1/2 | 810 | 6000 | 5500 | 5535 | 6000 | 5415 | — | — | 170 |
| | 4 1/2 to 7 | 18 1/2 to 22 1/2 | 4-16d | 4-16d | 6-10dx1 1/2 | 765 | 6000 | 5500 | 5535 | 6000 | 5415 | — | — | 170 |
| | 4 1/2 to 7 | 23 to 28 | 4-16d | 4-16d | 6-10dx1 1/2 | 635 | 6000 | 5500 | 5535 | 6000 | 5415 | — | — | 170 |
| | 4 1/2 to 7 | 28 1/2 to 32 | 4-16d | 4-16d | 8-10dx1 1/2 | 1005 | 6000 | 5500 | 5535 | 6000 | 5415 | — | — | 170 |

1. 16d sinkers (9 ga x 3") may be used where 10d commons are called out with no load reduction.
2. Uplift loads are based on Doug Fir, and have been increased 33% and 60% for wind or earthquake loading; no further increase allowed. Divide by 1.33 and 1.60 for normal loading like cantilever construction.

3. SCL, structural composite lumber, is laminated veneer lumber, Parallam® PSL and TimberStrand® LSL.
4. Applies to LVL headers made primarily from Douglas Fir or Southern Pine. For LVL made primarily from Spruce Pine Fir or similar less dense veneers, use the values found in the SPF column.
5. I-joist header with SPF flanges will support 2030 lbs.
Parallam® and TimberStrand® are registered trademarks of Trus Joist, a Weyerhaeuser company.