



✓ This product is preferable to similar connectors because of a) easier installation, b) higher loads, c) lower installed cost, or a combination of these features.

The STHD is an embedded strap tie holddown with high load capacity and a staggered nail pattern to help minimize splitting.

FEATURES

- The strap nailing pattern allows for nailing to the edges of double 2x's.
- A slot below the embedment line allows for increased front to back concrete bond and reduced spalling.
- Strap nail slots are countersunk to provide a lower nail head profile.
- Rim joist models accommodate up to a 17" clear span without any loss of strap nailing.
- Coined edges enhance safe handling.

MATERIAL: LSTHD8, LSTHD8RJ—14 ga, all others—12 ga. **FINISH:** Galvanized

INSTALLATION:

- Use all specified fasteners. See General Notes.
- See Post Tension information on page 31.
- **Install before concrete pour with a StrapMate, or other holding device.**
- Nail strap from the bottom up. **Strap may be bent one full cycle.**
- Bending the strap 90° to aid wall placement may cause spalling behind the strap. If the spall is 1" or less, measured from the embedment line to the bottom of the spall, full loads apply. For spalls between 1" and 4" (see illustration), the allowable load is 0.90 of the table loads.
- For two pour installations spalling is measured from the first pour.
- Where fewer fasteners are used in the structural wood member, reduce loads according to the code.
- Unless otherwise noted, do NOT install where: (a) a horizontal cold joint exists within the embedment depth between the slab and foundation wall or footing beneath, unless provisions are made to transfer the load, or the slab is designed to resist the load imposed by the anchor; or (b) slabs are poured over concrete block foundation walls.
- To get the full table load, the minimum center-to-center spacing is twice the embedment depth when resisting tension loads at the same time.
- **There is an increase in the amount of deflection if the strap is installed on the outside of the shear panel instead of directly to the framing. Ask for Form T-PLYWOOD for complete details.**
- **FOUNDATION CORNERS:** Nail quantities may be reduced for less than l_e corner distance design loads—use the code allowable loads for fasteners in shear.
- **To tie double 2x members together, the Designer must determine the fasteners required to bind members to act as one unit without splitting the wood.**
- **Additional studs attached to the shearwall studs or post may be required by the Designer for wall sheathing nailing.**

CODES: See page 10 for Code Listing Key Chart.

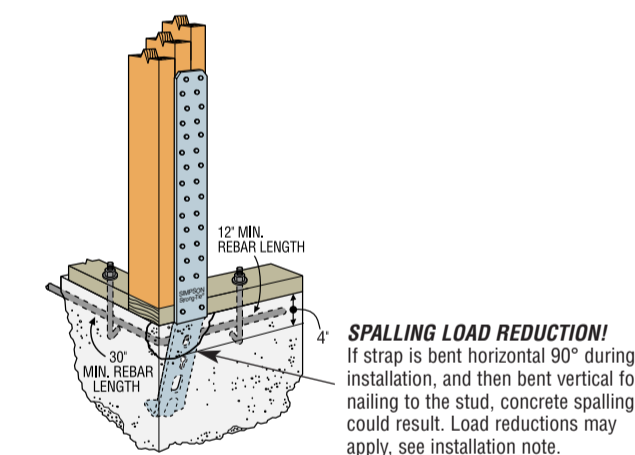
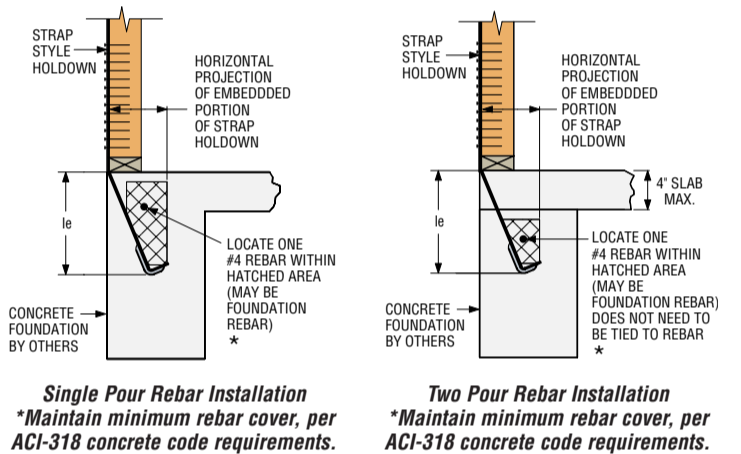
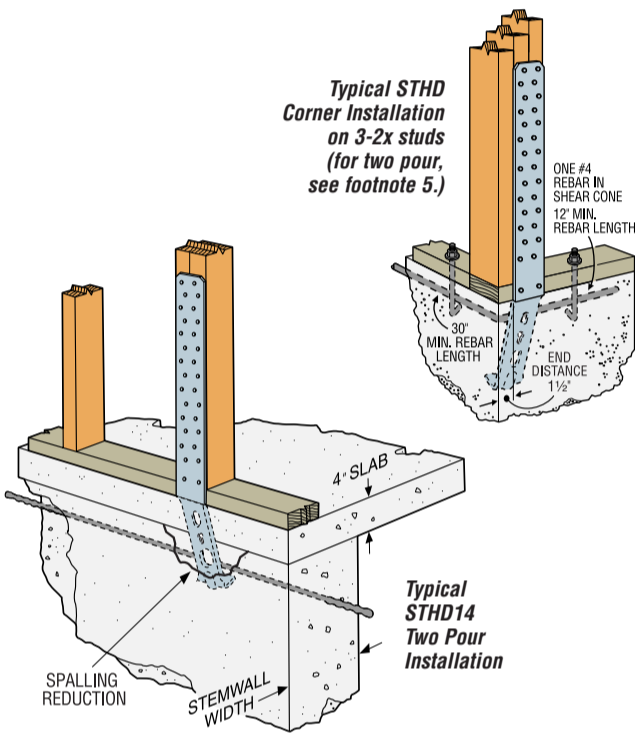
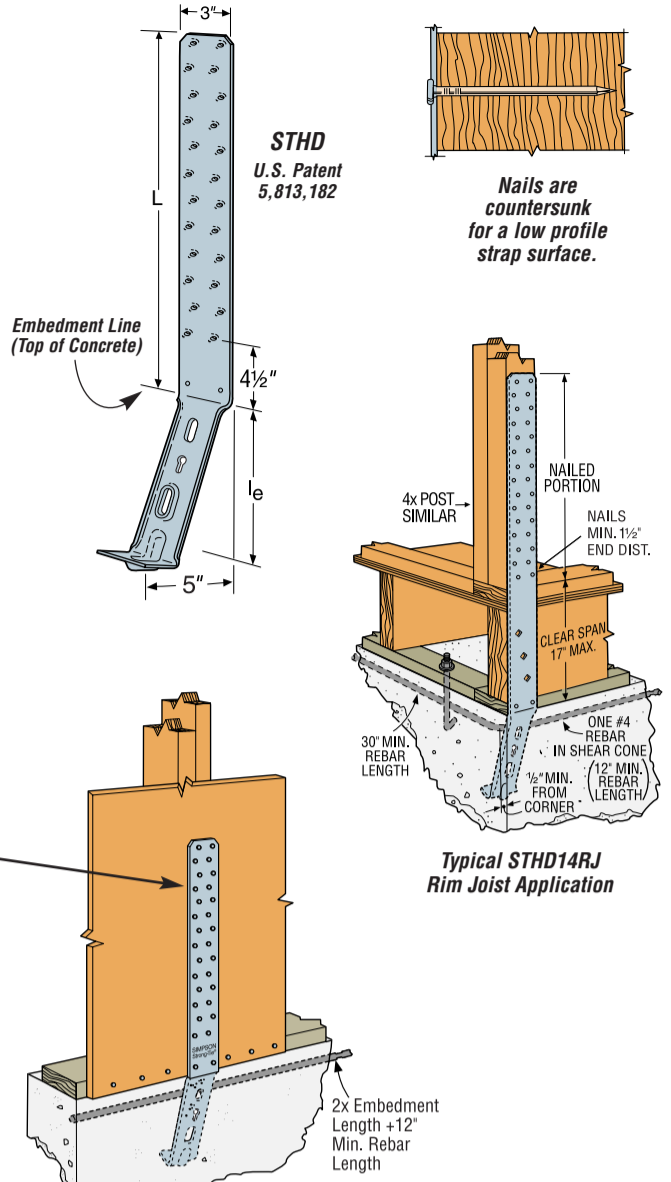

SPALL REDUCTION SYSTEM FOR STHD AND HPAHD

FEATURES

- Secures holddown to wood form-board.
- Allows for proper side-cover.
- Keeps strap vertical.
- Prevents tilting or twisting of strap during the concrete pour.
- Uses one 16d duplex nail.

BENEFITS

- Greatly reduces spalling and costly retrofits.
- Prevents strap movement parallel and perpendicular to plate.
- Decreases possibility of misinstallation of strap to wood member.
- Simple to use: — Common jobsite nail. — No additional expense.

Keyhole Feature Patent Pending

When using keyhole feature, care should be taken when removing form boards. If concrete is not set, the duplex nail will move the strap placement.

Model No. Standard / Rim Joist	Min Stem Wall	Strap Length (L)		l_e	Nails	Avg Ult @ 2000 psi l_e	Allowable Tension Loads (DF/SP/HF/SPF) (133 & 160)									Code Ref.
		Std Model	Rim Joist Model				End Distance									
							$1/2"$	$1/2"$	l_e	$1/2"$	$1/2"$	l_e	$1/2"$	$1/2"$	l_e	
							2000 psi Concrete			2500 psi Concrete			3000 psi Concrete			
LSTHD8 / LSTHD8RJ	6	21 5/8	35 5/8	8	24-16d sinker	5918	1695	1695	1695	1825	1825	1825	1950	1950	1950	32, 121, 122
STHD8 / STHD8RJ	6	21 5/8	35 5/8	8	24-16d sinker	7167	1760	2050	2345	1950	2210	2385	2135	2370	2425	
STHD10 / STHD10RJ	6	23 3/8	36 3/8	10	28-16d sinker	10555	2035	2575	3295	2610	2880	3295	3185	3185	3295	
STHD14 / STHD14RJ	6	31 3/8	39 3/8	14	38-16d sinker	15080	3235	4220	4805	3800	4295	4805	4365	4365	4805	
LSTHD8 / LSTHD8RJ	8	21 5/8	35 5/8	8	24-16d sinker	5918	1695	1695	1695	1825	1825	2335	1950	1950	2975	
STHD8 / STHD8RJ	8	21 5/8	35 5/8	8	24-16d sinker	7577	2370	2370	3195	2370	2370	3195	2370	2370	3195	
STHD10 / STHD10RJ	8	23 3/8	36 3/8	10	28-16d sinker	11780	2745	2745	3725	2990	2990	3725	3230	3230	3725	
STHD14 / STHD14RJ ²	8	31 3/8	39 3/8	14	38-16d sinker	17453	3885	4430	5785	4160	4430	5785	4430	4430	5785	

1. 'RJ' after the model indicates STHDs for rim joist applications, e.g. STHD8RJ.
2. STHD14RJ on 8" stemwall requires 30-16d sinkers, with the (l_e) load at 133% of 4960 lbs.
3. 10d commons or 12d common nails may be used with no load reduction.
4. Minimum nail end distance to prevent splitting is 10 x diameter, 1 1/2" for 16d sinkers, 10d common and 12d common.
5. For two pour with 4" slab or less. The STHD14 load at 1/2" end distance 2000 psi is 3235 lbs. and 4220 lbs. at 14" end distance. The STHD10 at the same condition is 2035 lbs. for 1/2" end distance, and 2750 lbs. at 10" end distance.
6. Allowable loads have been increased 33% and 60% for earthquake or wind loading with no further increase allowed; reduce where other loads govern.
7. Strap may be bent one full cycle.
8. Calculate loads using straight line interpolation for corner distances between 1/2" and l_e .
9. STHD14 and STHD14RJ installed on HF/SPF in an 8" stemwall: the l_e load is 5280 lbs.

POST-TENSION INFORMATION

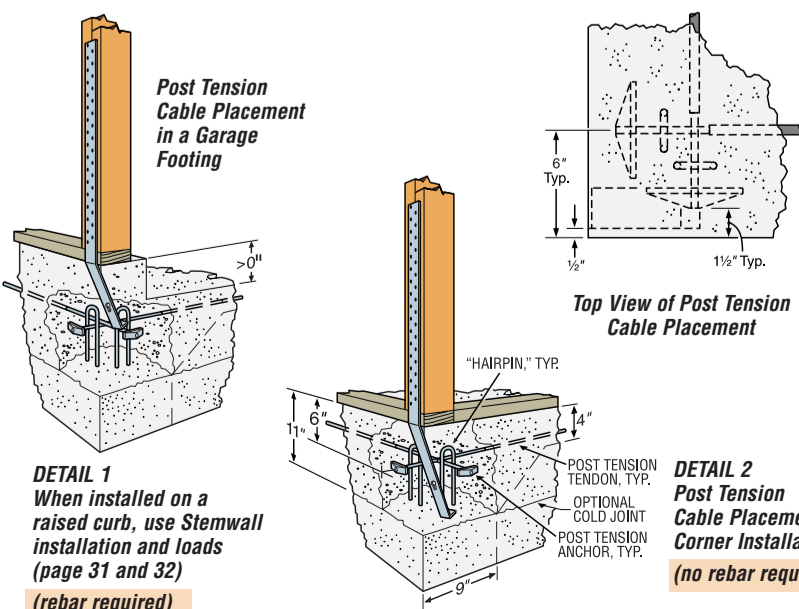

Model No.	Distance from Corner	Fasteners	Allowable Uplift Loads (133)	Code Ref.
HPAHD22	1/2" Min	13-16d	2705	20, 124
	8" Min	23-16d	4570	
LSTHD8/ LSTHD8RJ	1/2" Min	24-16d sinkers	1695	32, 121, 122
	8" Min	24-16d sinkers	1695	
STHD8/ STHD8RJ	1/2" Min	24-16d sinkers	2055	32, 121, 122
	8" Min	24-16d sinkers	2345	
STHD10/ STHD10RJ	1/2" Min	28-16d sinkers	2055	32, 121, 122
	10" Min	28-16d sinkers	3185	

1. Minimum concrete strength is 2500 psi.
2. Post-tension steel is minimum 1/2" diameter, 7-wire, low-relaxation strand in accordance with ASTM A416, Grade 270 ksi, with a guaranteed ultimate strength of 41.3 k.
3. Anchorage is monostrand-type anchor system with current ICBO approval using a ductile interlocking of at least 2.25" x 4.5" of bearing and reusable pocket casters on all stressing ends.
4. It is the designer's responsibility to provide reinforcement to tie cold-joints and to resist bearing stresses in the foundation due to anchor uplift.