

FINISH: LCB, CB44, CB46, CB66—galvanized; all other CB-Simpson gray paint or HDG.

INSTALLATION: • Use all specified fasteners. See General Notes.

- For full loads, minimum side cover required is 3" for CB, 2" for LCB.
- Install all models with bottom of base plate flush with concrete.
- Post bases do not provide adequate resistance to prevent members from rotating about the base and therefore are not recommended for non top-supported installations (such as fences or unbraced carports).
- **Contact engineered wood manufacturers for connections that are not through the wide face.**

OPTIONS: • The LCB may be shipped unassembled; specify "Disassembled".

- LCB and CB are available in rough size. Other sizes available for CB specify W1 and W2 dimensions. Consult Simpson for bolt sizes and allowable loads. See PBS.

CODES: See page 10 for Code Listing Key Chart.

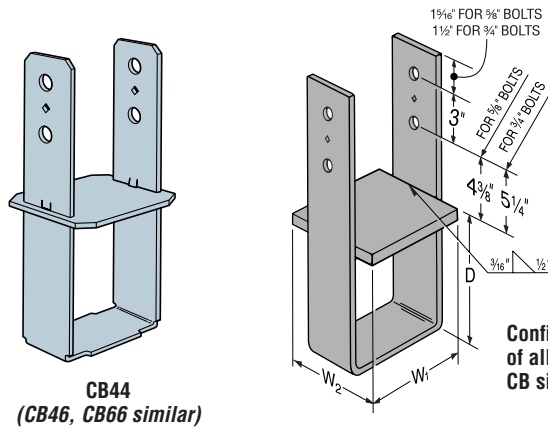

CB44
(CB46, CB66 similar)

Configuration of all other CB sizes

Available with additional corrosion protection. Check with factory.

Model No.	Nominal Column Size	Material		Dimensions			Column Fasteners		Uplift Avg UIt	Allowable Uplift Loads				Code Ref.
		Strap	Base (Ga)	W ₁	W ₂	D	Nails	Machine Bolts Qty Dia		Nails		Bolts		
										(133)	(160)	(133)	(160)	
LCB44	4x4	12 ga x2	16	3 3/16	3 3/16	6 1/2	12-16d	2 1/2	17853	2255	2705	3545	4250	2, 40
CB44	4x4	7 ga x2	7	3 3/16	3 3/16	8	—	2 5/8	14350	—	—	4200	4200	2, 40, 82, 121
LCB46	4x6	12 ga x2	16	3 3/16	5 1/2	6 1/2	12-16d	2 1/2	17853	2255	2705	3530	4240	2, 40
CB46	4x6	7 ga x2	7	3 3/16	5 1/2	8	—	2 5/8	14350	—	—	4200	4200	2, 40, 82, 121
CB48	4x8	7 ga x2	7	3 3/16	7 1/2	8	—	2 5/8	14350	—	—	4200	4200	
CB5-4.5	GLULAM	7 ga x3	7	4 9/16	5 3/8	8	—	2 5/8	14350	—	—	4200	4200	
CB5-6	GLULAM	7 ga x3	7	6 1/16	5 3/8	8	—	2 5/8	14350	—	—	4200	4200	
LCB66	6x6	12 ga x2	16	5 1/2	5 1/2	5 1/2	12-16d	2 1/2	17853	2255	2705	3525	4230	2, 40
CB64	6x4	7 ga x3	7	5 1/2	3 3/16	8	—	2 5/8	14350	—	—	4200	4200	2, 40, 82, 121
CB66	6x6	7 ga x3	7	5 1/2	5 1/2	8	—	2 5/8	14350	—	—	4200	4200	
CB6-7	6x	7 ga x3	7	5 1/2	7	8	—	2 5/8	14350	—	—	4200	4200	
CB7 1/2-4	PSL	3 ga x3	7	7 3/8	3 3/2	8	—	2 3/4	20650	—	—	6650	6650	
CB7 1/2-6	PSL	3 ga x3	7	7 3/8	5 1/2	8	—	2 3/4	20650	—	—	6650	6650	
CB7 1/2-7	PSL	3 ga x3	7	7 3/8	7	8	—	2 3/4	20650	—	—	6650	6650	
CB68	6x8	7 ga x3	7	5 1/2	7 1/2	8	—	2 5/8	14350	—	—	4200	4200	
CB7-6	GLULAM	3 ga x3	7	6 1/16	6 3/4	8	—	2 3/4	20650	—	—	6650	6650	
CB7-7.5	GLULAM	3 ga x3	7	7 9/16	6 3/4	8	—	2 3/4	20650	—	—	6650	6650	
CB7-9	GLULAM	3 ga x3	7	9 1/16	6 3/4	8	—	2 3/4	20650	—	—	6650	6650	
CB7-10.5	GLULAM	3 ga x3	7	10 9/16	6 3/4	8	—	2 3/4	20650	—	—	6650	6650	
CB86	8x6	3 ga x3	7	7 1/2	5 1/2	8	—	2 3/4	20650	—	—	6650	6650	
CB88	8x8	3 ga x3	7	7 1/2	7 1/2	8	—	2 3/4	20650	—	—	6650	6650	
CB9-6	GLULAM	3 ga x3	7	6 1/16	8 3/4	8	—	2 3/4	20650	—	—	6650	6650	
CB9-7.5	GLULAM	3 ga x3	7	7 9/16	8 3/4	8	—	2 3/4	20650	—	—	6650	6650	
CB9-9	GLULAM	3 ga x3	7	9 1/16	8 3/4	8	—	2 3/4	20650	—	—	6650	6650	
CB9-10.5	GLULAM	3 ga x3	7	10 9/16	8 3/4	8	—	2 3/4	20650	—	—	6650	6650	
CB1010	10x10	3 ga x3	3	9 1/2	9 1/2	8	—	2 3/4	20650	—	—	6650	6650	
CB1012	10x12	3 ga x3	3	9 1/2	11 1/2	8	—	2 3/4	20650	—	—	6650	6650	
CB1212	12x12	3 ga x3	3	11 1/2	11 1/2	8	—	2 3/4	20650	—	—	6650	6650	

1. Uplift loads have been increased 33% and 60% for earthquake or wind loading, with no further increase allowed; reduce where other loads govern.
2. PSL is parallel strand lumber.
3. LCB nail or bolt loads do not combine.

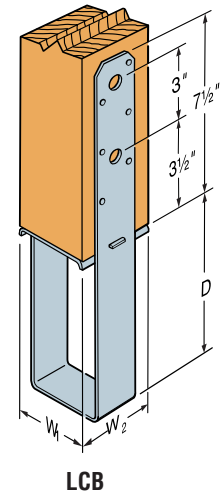

LCB

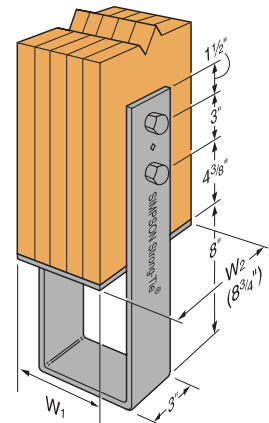

CB9
(CB5, CB7 similar) for glulam column