

MATERIAL: ECC3¼, ECC44, ECC46, ECC48, ECC64, ECC66, ECC68, ECC6-7½—7 gauge; all others—3 gauge

FINISH: Simpson gray paint; may be ordered HDG, ECCO — no finish.

INSTALLATION: • Use all specified fasteners. See General Notes.

• Bolt holes shall be a minimum of ¼" to a maximum of ⅛" larger than the bolt diameter (per 2001 NDS, section 11.1.2).

• **Contact engineered wood manufacturers for connections that are not through the wide face.**

OPTIONS: • Straps may be rotated 90° where $W_1 \geq W_2$ (see illustration).

• For special, custom, or rough cut lumber sizes, provide dimensions. An optional W_2 dimension may be specified with any column size given (note that the W_2 dimension on straps rotated 90° is limited by the W_1 dimension).

• Column caps with W_1 , L, H_1 , and hole schedules different from the table may be special ordered. Provide a drawing to ensure accuracy. Loads may not apply.

ECCO—Column cap only (*no straps*) may be ordered for field-welding to pipe or other columns. **No loads apply. ECCO dimensions are the same as ECC.**

ECCU—Order for uplift applications. See T-ECCUP for ordering information.

ECCL—L Column Cap. 7 gauge stirrups may be welded to column cap sides. **ECCL has no uplift loads.**

The following criteria apply:

1. The side stirrup maximum allowable download cannot exceed 40% of the download in the table for the unmodified product, and cannot exceed 10,665 lbs. The sum of the loads cannot exceed the table load. The column width in the direction of the beam width must be the same as the beam width: W_1 .

2. Specify the stirrup height from the top of the cap. The minimum H_2/H_3 for the stirrup is 6½" (3½" for 44s).

3. The L dimension may vary depending on W_3 or W_4 .

Ordering examples: An ECCLR66 with $W_3 = 3\frac{5}{8}$ ", $H_2 = 7\frac{1}{2}$ " is an ECC66 end column cap with a 4x beam on the right side (specify L instead of R for left side stirrup) and stirrup seat 1" below the cap seat.

CODES: See page 10 for Code Listing Key Chart.

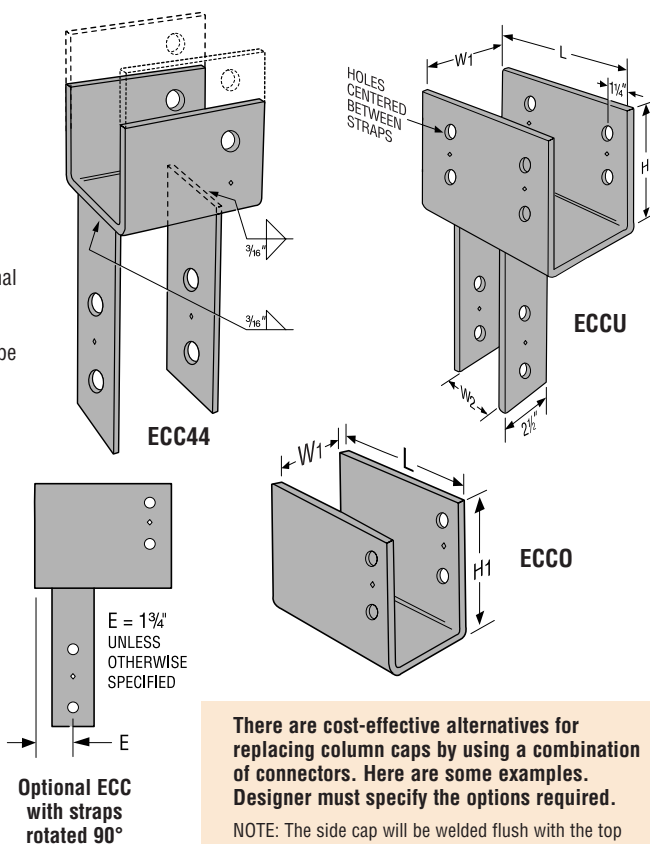

There are cost-effective alternatives for replacing column caps by using a combination of connectors. Here are some examples. Designer must specify the options required.

NOTE: The side cap will be welded flush with the top of the main cap.

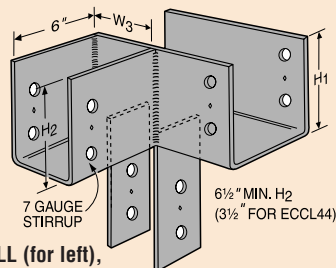

ECCLL (for left), shown above. Order ECCLR for right condition.

Side stirrups are available in different depths.

Instead of the column cap, consider this connector combination.

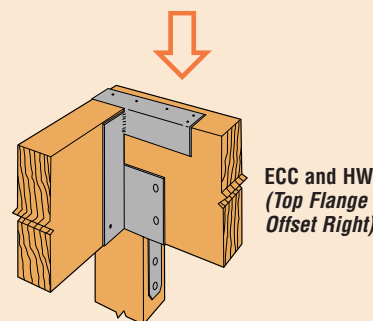

Order each connector separately. Specify all side stirrup widths and heights

For more information, request Form T-CC and the Product Worksheet.

Available with additional corrosion protection. Check with factory.

Model No.	Beam Width	Dimensions					Fasteners				Allowable Loads		Code Ref.	
		W_1	W_2	L ECC	L ECCU	H_1	Beam		Post		Uplift ECCU (133/160)	Down ECC/ECCU (100)		
							ECC	ECCU	Qty	Dia				Qty
ECC3¼-4	3½	3¼	3½	7½	9½	6½	2	4	⅝	2	⅝	1010	6125	20, 80
ECC3¼-6	3½	3¼	5½	7½	9½	6½	2	4	⅝	2	⅝	1010	9625	
ECC44	4x	3⅝	3⅝	5½	6½	4	1	2	⅝	2	⅝	205	7655	
ECC46	4x	3⅝	5½	8½	9½	6½	2	4	⅝	2	⅝	740	12030	
ECC48	4x	3⅝	7½	8½	9½	6½	2	4	⅝	2	⅝	740	16405	
ECC5¼-4	5½	5¼	3⅝	9½	10½	8	2	4	¾	2	¾	2735	10045	
ECC5¼-6	5½	5¼	5½	9½	10½	8	2	4	¾	2	¾	2735	15785	
ECC5¼-8	5½	5¼	7½	9½	10½	8	2	4	¾	2	¾	2735	21525	
ECC64	6x	5½	3⅝	7½	9½	6½	2	4	⅝	2	⅝	1165	12030	
ECC66	6x	5½	5½	7½	9½	6½	2	4	⅝	2	⅝	1165	18905	
ECC68	6x	5½	7½	9½	9½	6½	2	4	⅝	2	⅝	1165	25780	
ECC6-7½	6x	5½	7½	9½	9½	6½	2	4	⅝	2	⅝	1165	24060	
ECC7½-4	7	7½	3⅝	10½	10½	8	2	4	¾	2	¾	4855	18375	
ECC7½-6	7	7½	5½	10½	10½	8	2	4	¾	2	¾	4855	28875	
ECC7½-7½	7	7½	7½	10½	10½	8	2	4	¾	2	¾	4855	36750	
ECC7½-8	7	7½	7½	10½	10½	8	2	4	¾	2	¾	4855	36750	
ECC74	6¾	6¾	3⅝	10½	10½	8	2	4	¾	2	¾	3605	13230	
ECC76	6¾	6¾	5½	10½	10½	8	2	4	¾	2	¾	3605	20790	
ECC77	6¾	6¾	6¾	10½	10½	8	2	4	¾	2	¾	3605	25515	
ECC78	6¾	6¾	7½	10½	10½	8	2	4	¾	2	¾	3605	28350	
ECC86	8x	7½	5½	10½	10½	8	2	4	¾	2	¾	2625	23100	
ECC88	8x	7½	7½	10½	10½	8	2	4	¾	2	¾	2625	31500	
ECC96	8¾	8¾	5½	10½	10½	8	4	4	¾	2	¾	4670	26950	
ECC98	8¾	8¾	7½	10½	10½	8	4	4	¾	2	¾	4670	36750	
ECC106	10x	9½	5½	10½	10½	8	4	4	¾	2	¾	3325	29260	

1. Post sides are assumed to lie in the same vertical plane as the beam sides.
 2. Loads may not be increased for short-term loading.
 3. Downloads are determined using $F_c \perp$ equal to: 560 psi for glulam sizes; 750 psi for 7½" size; 625 psi for all others; reduce where end bearing value of post, L/R of post, or other criteria are limiting.

4. Uplift loads have been increased 33% and 60% for earthquake or wind loading; reduce where other loads govern. **Uplift loads are limited by the beam shear capacity** per 2001 NDS.
 5. ECC downloads assume a post of $W_1 \times W_2$.
 6. Uplift loads assume minimum beam height of 11". Beam shear must be calculated for different heights. The load cannot be greater than listed.
 7. Beam depth must be greater than H_1 .