



The IUS is preferable to similar connectors because of a) easier installation, b) higher loads, c) lower installed cost, or a combination of these features.

The improved IUS is now fully compatible with shallow flange I-joists! I-joists with flange thicknesses between  $7/16"$  and  $1\frac{1}{2}"$  achieve the full allowable table loads including uplift values and joist nails are not required! The IUS is a hybrid hanger that incorporates the advantages of the face mount and top mount hanger. Installation is fast with the Strong-Grip and Snap-In joist features along with easy-to-reach face nail locations and self-jigging locator tabs.

The MIU series hangers are designed for commercial and high load I-joist applications without requiring web stiffeners. The MIU features Positive Angle Nailing (PAN), which minimizes splitting of the flanges while permitting time-saving nailing from a better angle.

The IUT features a bend-tab which nails into the I-joist's bottom flange when web stiffeners are not used, or directly into the web stiffener. **Maximum flange thickness for bend-tab application is  $1\frac{1}{2}"$ .** This constrains the member, helping to reduce squeaks resulting from joist movement.

**MATERIAL:** See table page 79-81. **FINISH:** Galvanized

**UPLIFT LOADS:** • Models have optional triangle joist nail holes for additional uplift. Properly attached web stiffeners are required.

- IUT—add two additional  $10d \times 1\frac{1}{2}"$  joist nails for a total uplift load of 480 lbs and 575 lbs (33% and 60% increase respectively).
- MIU—add four additional  $10d \times 1\frac{1}{2}"$  joist nails for a total uplift load of 720 lbs and 865 lbs (33% and 60% increase respectively).
- IUS—for additional uplift capacity options refer to technical bulletin T-OPTUPLIFTCWP.

**INSTALLATION:** • Use all specified fasteners.

Verify that the header can take the required fasteners specified in the table. See pages 75-76 for more installation information.

- IUS—fasten hanger to header. Position I-joist into hanger and snap into place. No joist nailing required. Some IUS models have triangle and round header nail holes. To achieve Max. download, fill both round and triangle holes.

**IUS Locator tabs are not structural. They may be bent back to adjust for hanger placement.**

- IUT—optional seat diamond hole allows alternate attachment of hanger. See T-OPTUPLIFTCWP.
- Web stiffeners are not required with I-joists when the joist top flange is laterally supported by the sides of the hanger. I-joist manufacturers may require web stiffeners.

**OPTIONS:**

These hangers cannot be modified. However, these models will normally accommodate a skew of up to  $5^\circ$ . **For sloped joists up to  $1/4:12$  there is no reduction, between  $1/4:12$  and up to  $1/2:12$ , tests show a 10% reduction in ultimate hanger strength.** Local crushing of the bottom flange or excessive deflection may be limiting; check with joist manufacturer for specific limitations on bearing of this type.

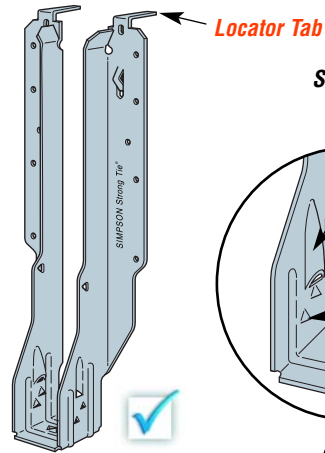

**IUS**  
(some IUS models have triangle holes in header flanges for Min/Max nailing)

U.S. Patent 6,523,321

**IUS INSTALLATION SEQUENCE**

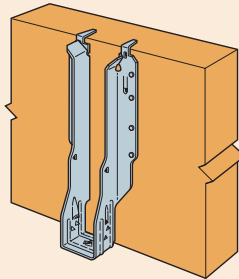

**STEP 1**  
Attach the IUS to the header

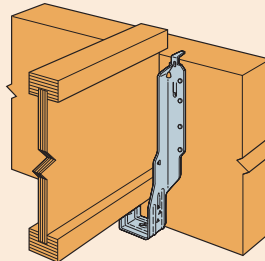

**STEP 2**  
Slide the I-joist downward into the IUS until it rests above the large teardrop.

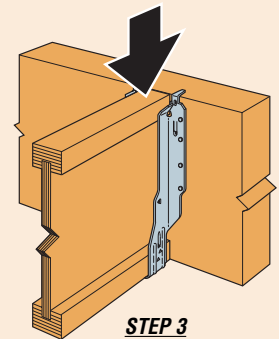

**STEP 3**  
Firmly push or snap I-joist fully into the seat of the IUS.

**MIU**

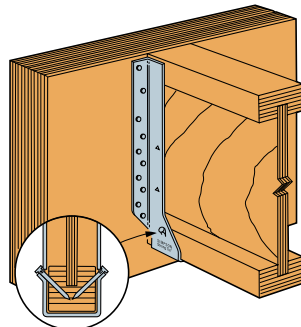
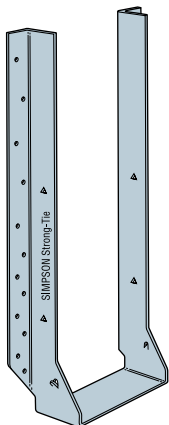

**MIU with correct PAN installation**

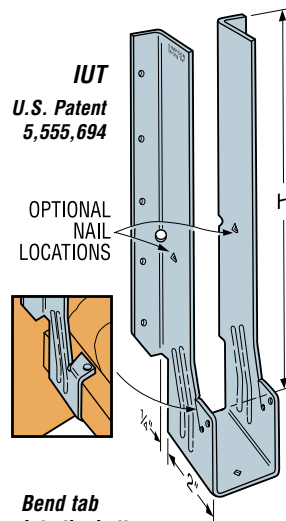

**IUT**  
U.S. Patent 5,555,694

OPTIONAL NAIL LOCATIONS



**Bend tab into the bottom flange and fasten with  $10d \times 1\frac{1}{2}"$  nails when web stiffeners are not used to help reduce floor squeaks.**

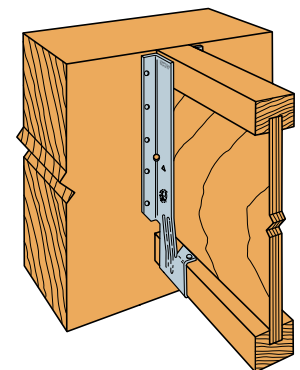

**Typical IUT Installation**