



This product is preferable to similar connectors because of a) easier installation, b) higher loads, c) lower installed cost, or a combination of these features.

A dedicated range of Top Flange I-joint hangers meeting the unique needs of I-joists while offering superior performance and ease of installation.

ITT - Bend Tab Nailing

Nail the ITT's special bend-tab with 10dx1½" nails at a slight angle into the bottom flange of the I-joist when web stiffeners are not used. The bend tab can also be nailed directly into the web stiffener. This constrains the I-joist, helping to reduce squeaks resulting from joist movement. Reduced embossing on the ITT's top flange, and the hanger height sized less than the joist height allow easier fitting for smooth floor alignment. **Maximum flange thickness for bend-tab application is 1½".**

MIT/HIT - Patented Positive Angle Nailing

This feature is specifically designed for wood web I-joists when used with the MIT or HIT. With Positive Angle Nailing (PAN), the slotted hole material is not removed, but is used to channel and confine the path of the nail to the optimum angle. PAN minimizes splitting of the flanges while permitting time-saving nailing from a better angle.

ITTM masonry-to-wood connectors can be directly embedded into a grouted block wall. It can also be installed on top of a masonry or concrete wall using Titen screws.

See Top Flange tables on pages 90 to 99.

MATERIAL: ITT—18 gauge; MIT, HIT—16 gauge, ITTM—12 gauge top flange and 18 gauge stirrup
FINISH: Galvanized

INSTALLATION: • Use all specified fasteners. Verify that the header can take the required fasteners specified in the table.

• ITT's face flange triangle hole **may be used with triangle holes in the joist for additional uplift** (optional); optional diamond hole in seat allows attachment of hanger to I-joist. See T-OPTUPLIFTCWP.

• ITT's bend-tab may be nailed unbent into plywood web stiffeners.

ALLOWABLE LOADS: • The ITT, MIT and HIT hangers have locations for optional nails if additional uplift is needed. Optional uplift nailing requires the addition of properly-secured web stiffeners. See the load tables for minimum required fasteners and allowable uplift loads.

OPTIONS: • Because these hangers are fully die-formed, they cannot be modified. However these models will normally accommodate a skew of up to 5°.

• For sloped joists up to ¼:12 there is no reduction, between ¼:12 and up to ½:12, tests show a 10% reduction in ultimate hanger strength. Local crushing of the bottom flange or excessive deflection may be limiting; check with joist manufacturer for specific limitations on bearing of this type.

CODES: See page 10 for Code Listing Key Chart.

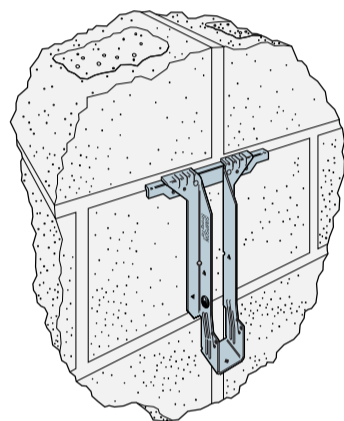
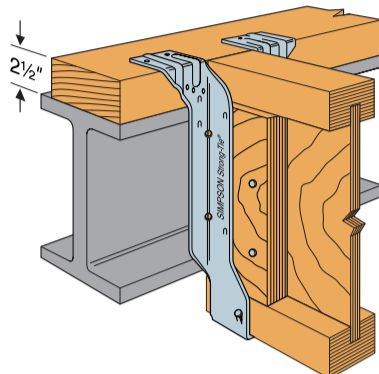
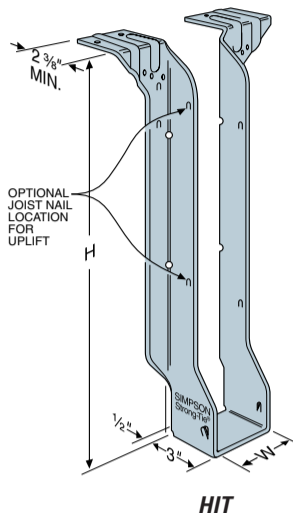
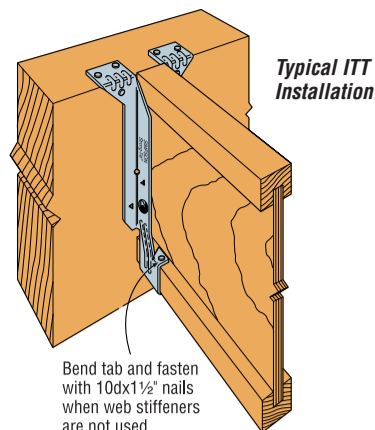
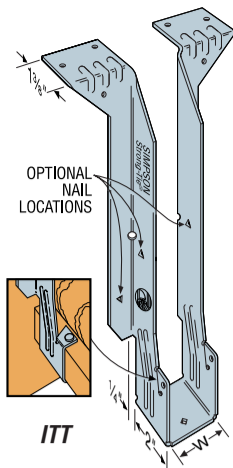

Typical ITTM Installed into Concrete Block (No Titen required)

U.S. Patent 5,555,694

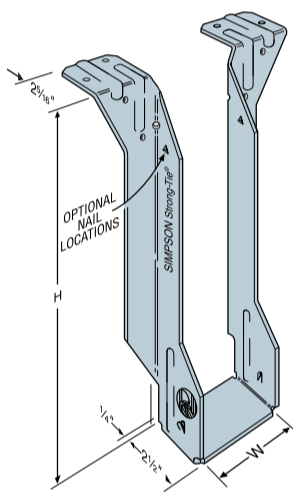

MIT

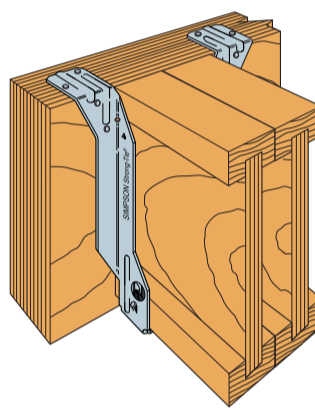

Typical MIT Installed on a Double LVL

POSITIVE ANGLE NAILING

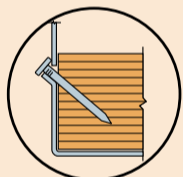

Correct Nailing



Nail Too Long



Nail at Wrong Angle Do Not Bend Tab Back

Some model configurations may differ from those shown on page 84. Contact factory for details.

IUT & ITT INSTALLATION (VPA SIMILAR)

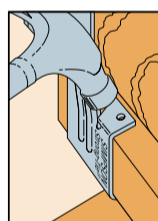

Bend the tab with a hammer.

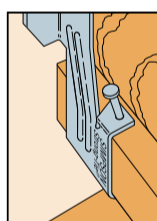

Hammer the nail in at an angle to prevent the wood from splitting.

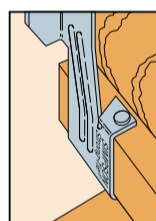

The tab is now correctly installed.

Use a 10dx1½ nail (Simpson N10 HDG shown)

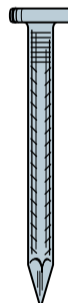

IT SERIES WITH VARIOUS HEADER APPLICATIONS

Model	Fasteners			Allowable Loads Header Type									Code Ref.
	Top	Face	Joist	Uplift ² (133)	Uplift ² (160)	DF/SP LVL ⁴	PSL	LSL	DF/SP	SPF	DF/SCL ⁵ I-Joist	SPF I-Joist	
ITT Series ⁶	4-10dx1½	2-10dx1½	2-10dx1½	245	285	1235	1225	1435	1235	1065	1050	755	8, 36, 91, 121
	4-10d	2-10d	2-10dx1½	245	285	1450	1300	1435	1615	1200	—	—	
	4-16d	2-16d	2-10dx1½	245	285	1500	1535	1500	1750	1315	—	—	
MIT Series	4-10dx1½	4-10dx1½	2-10dx1½	240	290	2035	1500	1605	1950	1115	1230	885	1, 84, 121
	4-10d	4-10d	2-10dx1½	240	290	2335	2000	1605	2400	1665	—	—	
	4-16d	4-16d	2-10dx1½	240	290	2550	2140	2115	2400	1665	—	—	
HIT Series	4-16d	6-16d	2-10dx1½	240	290	2550	2050	2500	3050	1950	—	—	2, 40, 82, 121

- Loads may not be increased for short-term loading.
- Uplift loads are based on Douglas Fir, and have been increased 33% and 60% for earthquake or wind loading with no further increase allowed. Divide by 1.33 and 1.60 for normal loading criteria like cantilever construction. For SPF use 0.86 x DF/SP uplift load.
- Titen masonry screws are only required into the masonry header when the hanger is installed on top of the wall. Header fasteners are ¼" x 2¼", see page 13.
- Applies to LVL headers made primarily from Douglas Fir or

- Southern Pine. For LVL made primarily from Spruce Pine Fir or similar less dense veneers, use the values found in the SPF column.
- DF I-joists include flanges made from solid sawn Douglas Fir, solid sawn Southern Pine, or DF-equivalent flanges made from Structural Composite Lumber. For flanges less than 1½" thick reduce table values by a factor of 0.85.
- Minimum solid header thickness to achieve ITT table loads is 1½".
- SCL, structural composite lumber, is laminated veneer lumber, Parallam® PSL and TimberStrand® LSL.
- Code Values are based on DF/SP header species.

Parallam® and TimberStrand® are registered trademarks of Trus Joist, a Weyerhaeuser company.

NAILER TABLE

This table indicates the maximum allowable loads for ITT/MIT/HIT hangers used on wood nailers. The header nail type must be substituted for those listed in other tables.

Model	Nailer	Header Nailing	Allowable Load		
			DF/SP	SPF	LSL
ITT Series	2x	6-10dx1½	1215	1215	1230
	3x	6-16dx2½	1550	1550	—
	2-2x	6-10d	1215	1200	—
	4x	6-16d	1550	1550	—
MIT Series	2x	8-10dx1½	1570 ¹	1440	1605
	3x	8-16dx2½	1975 ¹	—	—
	2-2x	8-10d	1570	1255	—
	4x	8-16d	2250 ¹	—	—
HIT Series	3x	10-16dx2½	2835	—	—
	2-2x	10-10d	2525	—	—
	4x	10-16d	3050 ¹	—	—

1. These hangers may deflect an additional ½" at design load.

OPTIONAL NAILING FOR INCREASED UPLIFT

Model	Fasteners			Allowable Uplift Loads	
	Top	Face	Joist	(133)	(160)
ITT	4-10dx1½	4-10dx1½	4-10dx1½	485	575
	4-10d	4-10d	4-10dx1½	485	575
	4-16d	4-16d	4-10dx1½	485	575
MIT	4-10dx1½	4-10dx1½	4-10dx1½	480	575
	4-16d	4-16d	4-10dx1½	480	575
HIT	4-16d	6-16d	4-10dx1½	480	575
	4-16dx2½	6-16dx2½	4-10dx1½	480	575
	4-16d	6-16d	6-10dx1½	720	850

- Loads are based on Doug Fir, and have been increased 33% and 60% for wind or earthquake loading with no further increase allowed. Reduce according to the code for normal loading criteria such as in cantilever construction.
- Web stiffeners are required on I-joist for additional nailing.