

One size works with any number of girder plies. The TBE transfers load from the truss or girder to plates for bearing-limited conditions, and provides exceptional uplift capacity. Replaces nail-on scabs that provide lower load transfer, or in some cases, an additional ply when needed for bearing.

The table lists allowable loads for TBE4 used on 2x4 and TBE6 used on 2x6 top plates. The table gives the different loads calculated for TBE with and without wood bearing. See Fastener Schedule below and page 123 for Alternate Installation.

MATERIAL: 18 gauge.

FINISH: Galvanized. See Corrosion-Resistance, page 5.

INSTALLATION: • Use all specified fasteners. See General Notes.

• TBE must be installed in pairs.

• Top plate size is 2x4 for TBE4, 2x6 for TBE6. Use alternate installation for TBE4 and TBE6 on larger plates or pre-sheathed walls. See page 123.

CODES: See page 10 for Code Listing Key Chart.

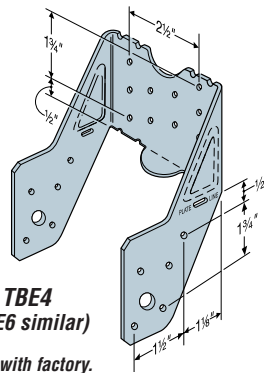

U.S. Patent 5,109,646
Canada Patent 2,044,440

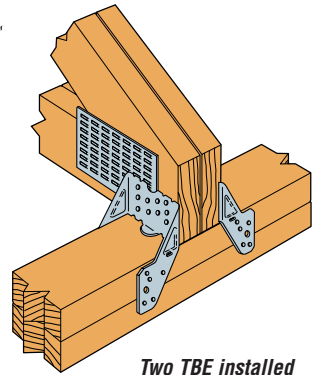

Two TBE installed with two ply girder truss

TBE FASTENER SCHEDULE

Available with additional corrosion protection. Check with factory.

Model No.	Truss Plys	Fasteners per each TBE	
		Rafter	Plate
TBE4	1	10-10dx1 1/2	10-10dx1 1/2
	2 or more	10-10d	10-10d
TBE6	1	10-10dx1 1/2	10-10dx1 1/2
	2 or more	10-10d	10-10d

No. of Truss Plys	Top Plate or Truss Wood Species ⁷	TBE Only Allowable Loads ^{1,4}							TBE & Wood Bearing Allowable Loads & Total Bearing Length (TBL) ^{1,4,8}							Code Ref.	
		Download				Uplift ³	Lateral (133)		(100)	TBL (in)	(115)	TBL (in)	(125)	TBL (in)	(133/160)		TBL (in)
		(100)	(115)	(125)	(133)	(133 & 160)	Parallel to Plate ⁶	Perp to Plate ⁵									
TBE4 ON 2x4 TOP PLATE																	
1	Doug-Fir-Larch	1820	2095	2230	2230	850	400	1000	5100	5.44	5375	5.73	5510	5.88	5510	5.88	33, 122, 127, 140
	Southern Pine	1820	2095	2230	2230	850	400	1000	4785	5.65	5060	5.97	5195	6.13	5195	6.13	
	Spruce-Pine-Fir	1560	1795	1950	2080	850	375	1000	3790	5.95	4025	6.32	4180	6.56	4310	6.76	
	Hem Fir	1560	1795	1950	2080	850	375	1000	3885	6.07	3920	6.45	4075	6.71	4205	6.92	
2	Doug-Fir-Larch	2220	2230	2230	2230	850	400	1000	8785	4.68	8795	4.69	8795	4.69	8795	4.69	
	Southern Pine	2220	2230	2230	2230	850	400	1000	8155	4.81	8165	4.82	8165	4.82	8165	4.82	
	Spruce-Pine-Fir	1920	2100	2100	2100	850	375	1000	6385	5.01	6565	5.15	6565	5.15	6565	5.15	
	Hem Fir	1920	2100	2100	2100	850	375	1000	6175	5.08	6355	5.23	6355	5.23	6355	5.23	
3	Doug-Fir-Larch	2220	2230	2230	2230	850	400	1000	12065	4.29	12075	4.29	12075	4.29	12075	4.29	
	Southern Pine	2220	2230	2230	2230	850	400	1000	11120	4.37	11130	4.38	11130	4.38	11130	4.38	
	Spruce-Pine-Fir	1920	2100	2100	2100	850	375	1000	8615	4.50	8795	4.60	8795	4.60	8795	4.60	
	Hem Fir	1920	2100	2100	2100	850	375	1000	8300	4.55	8480	4.65	8480	4.65	8480	4.65	
4	Doug-Fir-Larch	2220	2230	2230	2230	850	400	1000	15345	4.09	15355	4.09	15355	4.09	15355	4.09	
	Southern Pine	2220	2230	2230	2230	850	400	1000	14085	4.15	14095	4.16	14095	4.16	14095	4.16	
	Spruce-Pine-Fir	1920	2100	2100	2100	850	375	1000	10845	4.25	11025	4.32	11025	4.32	11025	4.32	
	Hem Fir	1920	2100	2100	2100	850	375	1000	10425	4.29	10605	4.36	10605	4.36	10605	4.36	
TBE6 ON 2x6 TOP PLATE																	
1	Doug-Fir-Larch	1820	2095	2275	2425	935	300	1000	6975	7.44	7250	7.73	7430	7.93	7580	8.09	33, 122, 127, 140
	Southern Pine	1820	2095	2275	2425	935	300	1000	6480	7.65	6755	7.97	6935	8.18	7085	8.36	
	Spruce-Pine-Fir	1560	1795	1950	2080	935	300	965	5065	7.95	5300	8.32	5455	8.55	5585	8.76	
	Hem Fir	1560	1795	1950	2080	935	300	965	4900	8.07	5135	8.45	5290	8.70	5420	8.92	
2	Doug-Fir-Larch	2220	2555	2735	2735	935	300	1000	12535	6.68	12870	6.86	13050	6.96	13050	6.96	
	Southern Pine	2220	2555	2735	2735	935	300	1000	11545	6.81	11880	7.01	12060	7.11	12060	7.11	
	Spruce-Pine-Fir	1920	2210	2400	2560	935	300	965	8935	7.01	9225	7.23	9415	7.38	9575	7.51	
	Hem Fir	1920	2210	2400	2560	935	300	965	8605	7.08	8895	7.32	9085	7.48	9245	7.61	
3	Doug-Fir-Larch	2220	2555	2735	2735	935	300	1000	17690	6.29	18025	6.41	18205	6.47	18205	6.47	
	Southern Pine	2220	2555	2735	2735	935	300	1000	16205	6.37	16540	6.50	16720	6.58	16720	6.58	
	Spruce-Pine-Fir	1920	2210	2400	2560	935	300	965	12440	6.50	12730	6.66	12920	6.75	13080	6.84	
	Hem Fir	1920	2210	2400	2560	935	300	965	11945	6.55	12235	6.71	12425	6.82	12585	6.90	
4	Doug-Fir-Larch	2220	2555	2735	2735	935	300	1000	22845	6.09	23180	6.18	23360	6.23	23360	6.23	
	Southern Pine	2220	2555	2735	2735	935	300	1000	20865	6.15	21200	6.25	21380	6.31	21380	6.31	
	Spruce-Pine-Fir	1920	2210	2400	2560	935	300	965	15945	6.25	16235	6.37	16425	6.44	16585	6.50	
	Hem Fir	1920	2210	2400	2560	935	300	965	15285	6.29	15575	6.41	15765	6.49	15925	6.55	

1. Loads are for two TBEs only. Allowable wood bearing load may be added as shown in the table.
2. Allowable loads for four wood species at F_{c⊥} for Douglas Fir-Larch = 625, Southern Pine = 565; Spruce-Pine-Fir = 425; Hem Fir = 405.
3. Allowable loads have been increased 33% and 60% for earthquake or wind loading with no further increase allowed; reduce where other loads govern.
4. Allowable loads are determined only by nail shear calculations or tests of the metal connectors based on the lowest of 0.125" of deflection or the ultimate load with a 3 times factor of safety. The attached wood members must be designed to withstand the loads imposed by the nails.

5. Perpendicular to Plate loads are reduced for Alternate Installation.
6. Parallel to Plate loads are not reduced for Alternate Installation.
7. Use lower of top plate or truss wood species.
8. Total bearing length, TBL, equals the plate width plus simulated bearing length provided by the TBE. TBE4 = 3 1/2" plate width; TBE6 = 5 1/2".

ALTERNATE INSTALLATION

(See illustrations at right)

Model No.	Alternate Installation Allowable Loads ^{5,6}			
	Doug-Fir-Larch/So. Pine		Spruce-Pine-Fir	
	(133/160)		(133/160)	
	F ₂	F ₃	F ₂	F ₃
TBE4	1000	300	860	260
TBE6				

See table footnotes on opposite page.

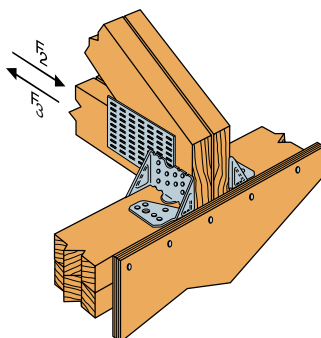

Pre-sheathed shearwall. Bend tab along slot and nail one leg to top of the plate.

Alternate Installation Allowable Down Loads are 0.80 of the TBE only table loads on page 122.

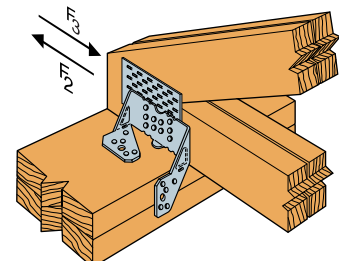

TBE6 Installed on Double 2x8 Top Plate