

DAMMON

ENGINEERING, INC.

554 Old Spanish Trail
Slidell, LA 70458
985.649.5832

www.dammonengineering.com
info@dammonengineering.com

Architects & Engineers

SHOP DRAWING and SAMPLE TRANSMITTAL

DATE: **5/13/2025**

TO: Cheri Rusich
M Natal Contractor, Inc.
P.O. Box 518
Slidell, La

FROM: Chuck Dammon

SUBMITTAL No.: 230000-001-0

REFERENCE: **STP Fire District 1 Training Center #2**

DE Project: 2507

WE TRANSMIT:

enclosed under separate cover _____

FOR YOUR:

use record approval
 review and comment information drafting

THE FOLLOWING:

drawing(s) contracts specifications
 shop drawings samples change order(s)
 product information warranty substitution request

# COPIES	DESCRIPTION	ACTION
Electronic	2 split system A/C unit	A

ACTION CODES:

- | | | | |
|----|---------------------------|----|---|
| A. | Reviewed/No Exceptions | D. | No Action Required |
| B. | Reviewed/Exceptions Noted | E. | For Signature and Return to this Office |
| C. | Revise and Resubmit | F. | See Remarks Below |
| G. | Rejected | | |

REMARKS:

2 split system A/C unit

COPIES TO: File



Project: STFD No.1 New Training Facility-Slidell #2
 34780 S. Range Road
 Slidell, Louisiana 70460

SUBMITTAL COVER SHEET

Arch. Project No: _____

MNC Project No: 830

To: Dammon Engineering, Inc.
554 Old Spanish Trail
Slidell, Louisiana 70458
info@dammonengineering.com

From: Cheri Rusich
M Natal Contractor, Inc.
P.O. Box 518
Slidell, LA 70459

Attn. David Dammon
Chuck Dammon

Sent Via E-Mail

General Contractor's Review:

M Natal Contractor, Inc.

CONTRACTOR'S REVIEW:

SUBMITTAL NO: 230000.001.0
SPEC. SEC. NO: 230000
VENDOR/SUB: Lanes AC
DESCRIPTION: 2 split system A/C unit

NO EXCEPTIONS TAKEN
FURNISH AS CORRECTED
REJECTED; RESUBMIT
PARTIAL APPROVAL; SUBMIT ADD'L ITEM(S)

Reviewing is for conformance with the design concept of the project and compliance with the information given in the Contract Documents. The Vendor/Subcontractor is responsible for dimensions to be confirmed and correlated at the site for information that pertains solely to the fabrication process or to the means, method, technician, sequences, and procedures of construction; and for coordination of the work with all trades.

BY CR DATE: 05/13/2025

Architect/Engineer Review:

DAMMON ENGINEERING, INC

Date: 05-13-25 Project: New Training Facility #2
 Reviewed: _____
 Reviewed as noted: _____
 Revise and ReSubmit: _____
 Rejected: _____
 Other: _____

Correction or comments made on the shop drawings during this review do not relieve the contractor from compliance with requirements of the drawings and specifications. This check is only for review of the general conformance with the design concept of the project and general compliance with the information given in the contract documents. This contractor is responsible for: confirming and correlating all quantities and dimensions, selecting fabrication processes and techniques of construction; coordinating his or her work with that of all other trades and performing all in a safe and satisfactory manner.

Submittal item: 2 Split System A/C Unit
 Comments: _____



Submittal

Prepared For:
Lane's AC & Htg

Date: May 07, 2025

Job Name:
STPFDF Fire Protection Dist 1 New Training Facility

Opportunity ID: 7543371

Trane U.S. Inc. is pleased to provide the following submittal for your review and approval.

Product Summary

Qty Product

2 Split System Air Conditioning Units (Small)

Kimberly Fricke
Trane U.S. Inc.
4013 N Interstate 10 Service Rd W
Metairie, LA 70002
Office Phone: (504) 733-6789

The attached information describes the equipment we propose to furnish for this project and is submitted for your approval.

Submittal acceptance and return is a critical step, so please ensure submittals are returned with approval to release to production within 14 days of submittal date.

Product performance and submittal data is valid for a period of 6 months from the date of submittal generation. If six months or more has elapsed between submittal generation and equipment release, the product performance and submittal data will need to be verified. It is the customer's responsibility to obtain such verification.

Table of Contents

Product Summary	1
Split System Air Conditioning Units (Small) (Items A1, A2)	3
Tag Data	3
Product Data.....	3
Performance Data.....	4
Mechanical Specifications	5
Dimensional Drawings.....	6
Weight, Clearance & Rigging	10
Field Installed Options - Part/Order Number Summary	11
Split System Air Conditioning Units (Small)	11

Tag Data - Split System Air Conditioning Units (Small) (Qty: 2)

Item	Tag(s)	Qty	Description	Model Number
A1	AHU-HP-1	1	1.5 - 5 Ton Unitary Split Systems (SSC)	5TWR7048A1 - 5TAM5D06AC41S
A2	AHU-HP-2	1	1.5 - 5 Ton Unitary Split Systems (SSC)	5TWR7048A1 - 5TAM5D07AC51S

Product Data - Split System Air Conditioning Units (Small)**All Units**

5TWR7 Split System Single Stage Heat Pump Outdoor Unit, R-454B

4 Ton Nominal Cooling Capacity

200/230/60/1

5TAM - Hyperion Air Handler, R-454B

Multi-position upflow/downflow/horizontal left/horizontal right

23.5" Cabinet Width

Constant Torque Motor

208-230/60/1

24 Volt Controls

Touchscreen Programmable Thermostat, 4H/2C (Field Installed)

2.88/3.84 kW Heater 208/240/60/1 (Field Installed)

Item: A1 Qty: 1 Tag(s): AHU-HP-1

36 - 60 MBH Cooling Capacity

4 Tons

Item: A2 Qty: 1 Tag(s): AHU-HP-2

42 - 60 MBH Cooling Capacity

5 Tons

Performance Data - Split System Air Conditioning Units (Small)

Tags	AHU-HP-1	AHU-HP-2
Design cooling EDB (F)	80.00	80.00
Design cooling EWB (F)	67.00	67.00
Design cooling outdoor DB (F)	95.00	95.00
Cooling EDB (F)	80.00	80.00
Cooling EWB (F)	67.00	67.00
Elevation (ft)	0.00	0.00
Heating outdoor DB (F)	17.00	17.00
Heating EDB (F)	70.00	70.00
ID AHRI Model (Each)	6763985.00	6763987.00

Mechanical Specifications - Split System Air Conditioning Units (Small)**Item: A1, A2 Qty: 2 Tag(s): AHU-HP-1, AHU-HP-2****5TAM5**

- Unique cabinet design-
 - Double Wall Foamed and Formed Cabinet System
 - Waterproofs Cabinet Design-
 - R-4.2 Insulating Value (Avg Insulating Value R-8.2)
 - Composite Doors -
 - Sweat Eliminating Cabinet Design-
 - Loose Fiber Eliminating Cabinet Design-
 - Smooth Cleanable Cabinet Design-
 - 2% or Less Air Leakage-
 - Precision Durable Door Seals- Modular Cabinet
- Multi-position up/down flow horizontal left/right
- Phillips head door fasteners
- Return Option
- Refrigerant Connections
- Condensate Connections
- Premarked Conduit Connection Locations
- Vortica Blower with Integrated Slide Deck for Easy Removal
- Polarized Plug connections on Blower
- Aluminum Coil with Integrated Slide Deck for Easy Removal
- Polarized Plug connections for Electric Heater
 - Labeled Panels and connections
- 1 1/4" to 1" And 3/4" to 1/2" Conduit connection on Left, Right and Top
- Molded in 1" Standard Filter rail
- R-454B Thermal Expansion Valve
- Low Voltage Pigtail Connections
- Enhanced Coil Fin Patented
- Blow Through Design
- High Efficiency ECM Motor
- Maximum Width of 23.5"
- Compact 20.8" depth with doors removed
- Integrated Horizontal Drain pans
- Soft start fan motor operation
- Single Color
- Fused 24V Power

5TWR7 General

This unit is designed to operate at outdoor ambient temperatures from 55° F to 120° F in cooling. From -0° F to 66° F in heating (heat pumps only). Only AHRI approved indoor matches are approved for use with these models.

5TWR7 Casing

Unit casing is constructed of heavy gauge. G60 galvanized steel and painted with a weather-resistant powder paint on all louvered panels and prepaint on all other panels. Corrosion and weatherproof CMBP-G30 DuraTuff base

5TWR7 Refrigerant Controls

Refrigeration system controls include condenser fan, compressor inverter drive and high and low pressure switches. A factory supplied, field installed filter is standard.

5TWR7 Compressor

Inverter driven compressor with variable output capacities. Compressor protections reduce operating speed and current draw to maintain operation while protecting the compressor.

5TWR7 Condenser Coil

The Spine Fin outdoor coil provides low airflow resistance and efficient heat transfer. The coil is protected on all four sides by louvered panels.

Dimensional Drawings - Split System Air Conditioning Units (Small)

Item: A1, A2 Qty: 2 Tag(s): AHU-HP-1, AHU-HP-2

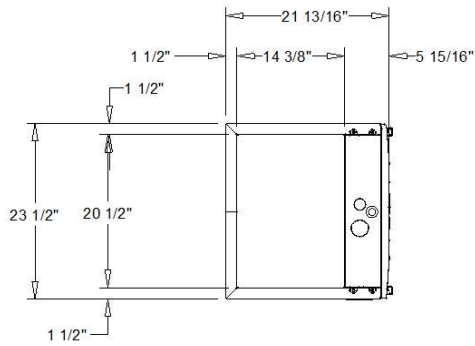

NOTES:
1. VERIFY WEIGHT, CONNECTION, AND ALL DIMENSION WITH INSTALLER DOCUMENTS BEFORE INSTALLATION

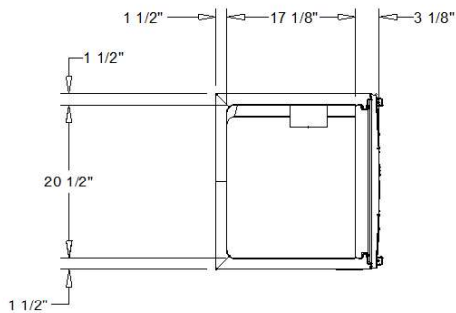
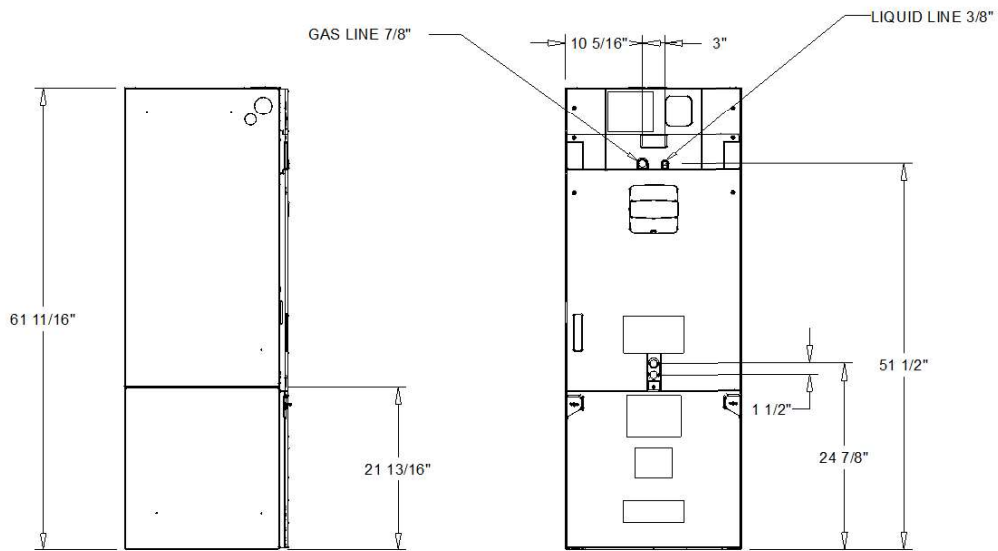

AIRHANDLER
DRAWING

Dimensional Drawings - Split System Air Conditioning Units (Small)
Item: A1 Qty: 1 Tag(s): AHU-HP-1

ELECTRICAL / GENERAL DATA

<p>GENERAL ⁽¹⁾⁽²⁾⁽⁴⁾</p> <p>Model: 5TAM5D06AC41SA</p> <p>Unit Primary Voltage: 208</p> <p>Unit Secondary Voltage: 230</p> <p>Unit Hertz: 60</p> <p>Unit Phase: 1</p>	<p>INDOOR MOTOR ⁽¹⁾</p> <p>Number: 1</p> <p>Horsepower: -</p> <p>Motor Speed (RPM): 1050</p> <p>Phase: 1</p> <p>Full Load Amps: 5.4</p> <p>Locked Rotor Amps:</p>	<p>FILTERS ⁽³⁾</p> <p>Type: Throwaway</p> <p>Furnished: No</p> <p>Number: 1</p> <p>Recommended: 22"x20"x1"</p>
<p>STANDARD ⁽⁵⁾</p> <p>230 Volt / 208 Volt</p> <p>Minimum Circuit Ampacity: 7.0/7.0</p> <p>Maximum Overload Protection: 15.0/15.0</p>	<p>REFRIGERANT</p> <p>Type: R-454A</p> <p>REF. Line Connections</p> <p>Coupling or Conn. Size - Gas: 7/8"</p> <p>Coupling or Conn. Size - Liq.: 3/8"</p>	<p>Weights</p> <p>Shipping: 176.0 lb</p> <p>Net: 166.0 lb</p>
<p>ELECTRIC HEAT</p> <p>240 Volt / 208 Volt</p> <p>Capacity Circuit #1: 3.84/2.88</p> <p>Capacity Circuit #2: N/A</p> <p>Capacity Circuit #3: N/A</p> <p># of Circuit: 1</p> <p>Phase: 1</p> <p>Heater Amps Per Circuit Circuit #1: 16.0/13.8</p> <p>Heater Amps Per Circuit Circuit #2: N/A</p> <p>Heater Amps Per Circuit Circuit #3: N/A</p> <p>Minimum Circuit Ampacity Circuit #1: 27.0/24.0</p> <p>Minimum Circuit Ampacity Circuit #2: N/A</p> <p>Minimum Circuit Ampacity Circuit #3: N/A</p> <p>Maximum Overload Protection Circuit #1: 30.0/25.0</p> <p>Maximum Overload Protection Circuit #2: N/A</p> <p>Maximum Overload Protection Circuit #3: N/A</p>	<p>NOTES:</p> <ol style="list-style-type: none"> 1. These air handlers are a.r.i. certified with various split system air conditioners and heat pumps (ari standard 210/240). refer tothesplit system outdoor unit product data guides for performance data. 2. 3/4" male plastic pipe (ref.: astm 1785-76) 3. Minimum filter size for horizontal applications will be based on airflow selection and will be calculated as follows: low velocity filter: face area (sq. ft.) = cfm / 300 high velocity filter: face area (sq. ft.) = cfm / 500 4. For customer ease of filter maintenance, it is recommended that a properly sized, remote filter and grille be installed for horizontal applications. airflow should not exceed the face value of the filter being used 5. Standard mca and mop without electric heat. 	

Dimensional Drawings - Split System Air Conditioning Units (Small)
Item: A1, A2 Qty: 2 Tag(s): AHU-HP-1, AHU-HP-2

ELECTRICAL / GENERAL DATA

MODEL:	5TWR7048A1000*
POWER CONNS. V/PH/HZ:	208/230/1/60
MINIMUM CIRCUIT AMPACITY:	36.0
MAXIMUM CIRCUIT BREAKER:	50.0
MINIMUM PROTECTION RATING:	50.0
MAC:	39.2
FAN HP:	0.50
MOC:	2.3
FAN DIA:	27 7/8"
COIL:	SPINE FIN
REFRIGERANT (R - 454B):	6.5 lb
LINE SIZE O.D. GAS:	7/8"
LINE SIZE O.D. LIQUID:	5/16"

1. CERTIFIED IN ACCORDANCE WITH THE UNITARY AIR-CONDITIONER EQUIPMENT CERTIFICATION PROGRAM WHICH IS BASED ON AHRI STANDARD 210/240.
2. CALCULATED IN ACCORDANCE WITH N.E.C. USE ONLY HACR CIRCUIT BREAKERS OR FUSES.
3. STANDARD LINE LENGTHS - 60'. STANDARD LIFT - 60' SUCTION AND LIQUID LINE. FOR GREATER LENGTHS AND LIFTS REFER TO REFRIGERANT PIPING SOFTWARE PUB# 32-3312-0
4. * = 15, 20, 25, 30, 40 AND 50 FOOT LINESET AVAILABLE.

WEIGHTS

SHIPPING:	264.0 lb
NET:	241.0 lb

NOTES:

- C1. TOP DISCHARGE SHOULD BE UNRESTRICTED FOR AT LEAST 60" ABOVE UNIT
- C2. PLACE UNIT FROM WALL
- C3. PLACE SHRUBBERY AT LEAST 12" FROM UNIT ON TWO SIDES, OTHER SIDES UNRESTRICTED
- C4. PLACE UNIT SO ROOF RUN-OFF DOES NOT FALL DIRECTLY ON UNIT

NOTES

1. TOP DISCHARGE AREA SHOULD BE UNRESTRICTED FOR AT LEAST 60" ABOVE UNIT. UNIT SHOULD BE PLACED SO ROOF RUN-OFF WATER DOES NOT POUR DIRECTLY ON UNIT, AND SHOULD BE AT LEAST 12" FROM WALL AND ALL SURROUNDING SHRUBBERY ON TWO SIDES. OTHER TWO SIDES UNRESTRICTED.
2. ELECTRICAL AND REFRIGERANT COMPONENT CLEARANCES PER PREVAILING CODES.
3. VERIFY WEIGHT, CONNECTION, AND ALL DIMENSION WITH INSTALLER DOCUMENTS BEFORE INSTALLATION

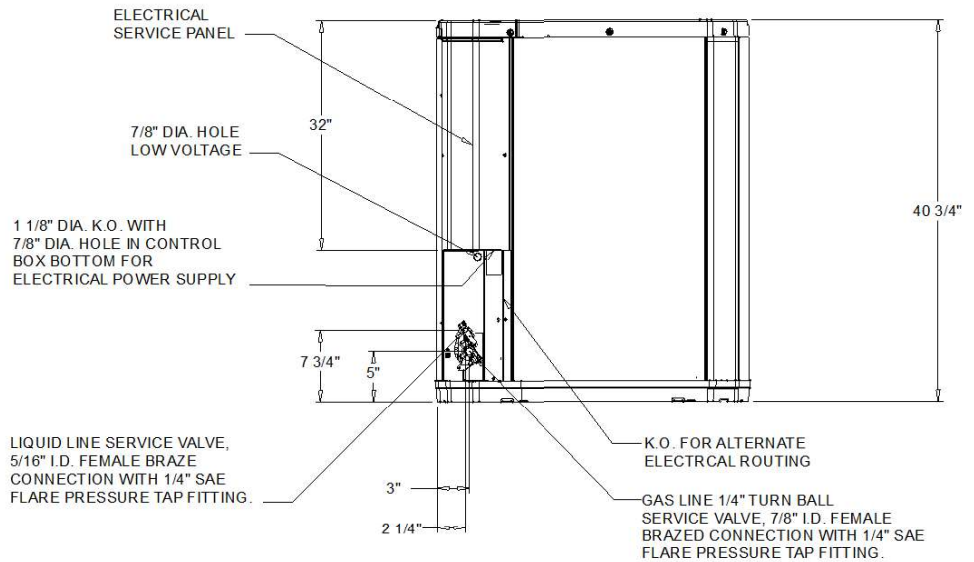
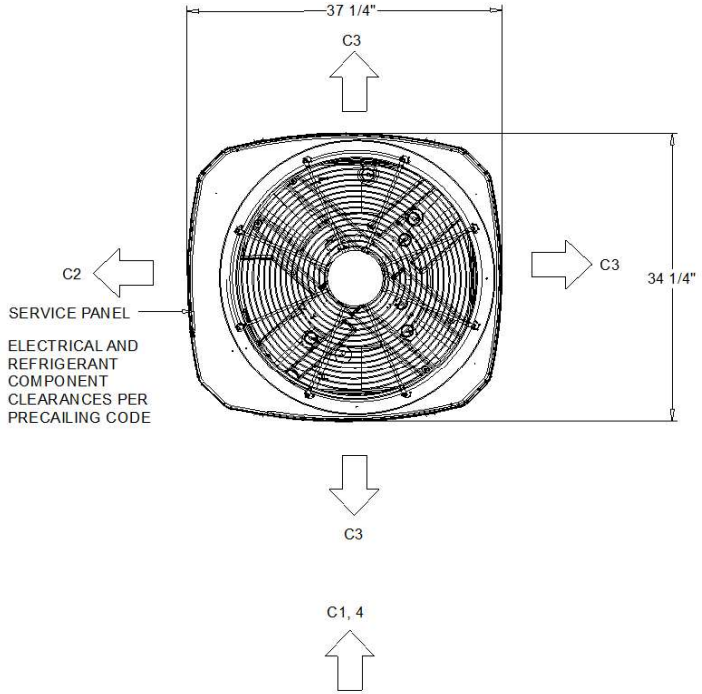

5TWR7048A1000A
 OUTLINE DRAWING

Dimensional Drawings - Split System Air Conditioning Units (Small)
Item: A2 Qty: 1 Tag(s): AHU-HP-2

ELECTRICAL / GENERAL DATA

<p>GENERAL ⁽¹⁾⁽²⁾⁽⁴⁾</p> <p>Model: 5TAM5D07AC51SA</p> <p>Unit Primary Voltage: 208</p> <p>Unit Secondary Voltage: 230</p> <p>Unit Hertz: 60</p> <p>Unit Phase: 1</p>	<p>INDOOR MOTOR ⁽¹⁾</p> <p>Number: 1</p> <p>Horsepower: -</p> <p>Motor Speed (RPM): 1050</p> <p>Phase: 1</p> <p>Full Load Amps: 7.0</p> <p>Locked Rotor Amps: -</p>	<p>FILTERS ⁽³⁾</p> <p>Type: Throwaway</p> <p>Furnished: No</p> <p>Number: 1</p> <p>Recommended: 22"x20"x1"</p>
<p>STANDARD ⁽⁵⁾</p> <p>230 Volt / 208 Volt</p> <p>Minimum Circuit Ampacity: 9.0/9.0</p> <p>Maximum Overload Protection: 15.0/15.0</p>	<p>REFRIGERANT</p> <p>Type: R-454B</p> <p>REF. Line Connections</p> <p>Coupling or Conn. Size - Gas: 7/8"</p> <p>Coupling or Conn. Size - Liq.: 3/8"</p>	<p>Weights</p> <p>Shipping: 180.0 lb</p> <p>Net: 170.0 lb</p>
<p>ELECTRIC HEAT</p> <p>240 Volt / 208 Volt</p> <p>Capacity Circuit #1: 3.84/2.88</p> <p>Capacity Circuit #2: N/A</p> <p>Capacity Circuit #3: N/A</p> <p># of Circuit: 1</p> <p>Phase: 1</p> <p>Heater Amps Per Circuit Circuit #1: 16.0/13.8</p> <p>Heater Amps Per Circuit Circuit #2: N/A</p> <p>Heater Amps Per Circuit Circuit #3: N/A</p> <p>Minimum Circuit Ampacity Circuit #1: 29.0/26.0</p> <p>Minimum Circuit Ampacity Circuit #2: N/A</p> <p>Minimum Circuit Ampacity Circuit #3: N/A</p> <p>Maximum Overload Protection Circuit #1: 30.0/30.0</p> <p>Maximum Overload Protection Circuit #2: N/A</p> <p>Maximum Overload Protection Circuit #3: N/A</p>	<p>NOTES:</p> <ol style="list-style-type: none"> 1. These air handlers are a.r.i. certified with various split system air conditioners and heat pumps (ari standard 210/240). refer tothesplit system outdoor unit product data guides for performance data. 2. 3/4" male plastic pipe (ref.: astm 1785-76) 3. Minimum filter size for horizontal applications will be based on airflow selection and will be calculated as follows: low velocity filter: face area (sq. ft.) = cfm / 300 high velocity filter: face area (sq. ft.) = cfm / 500 4. For customer ease of filter maintenance, it is recommended that a properly sized, remote filter and grille be installed for horizontal applications. airflow should not exceed the face value of the filter being used 5. Standard mca and mop without electric heat. 	

Weight, Clearance & Rigging - Split System Air Conditioning Units (Small)
Item: A1, A2 Qty: 2 Tag(s): AHU-HP-1, AHU-HP-2

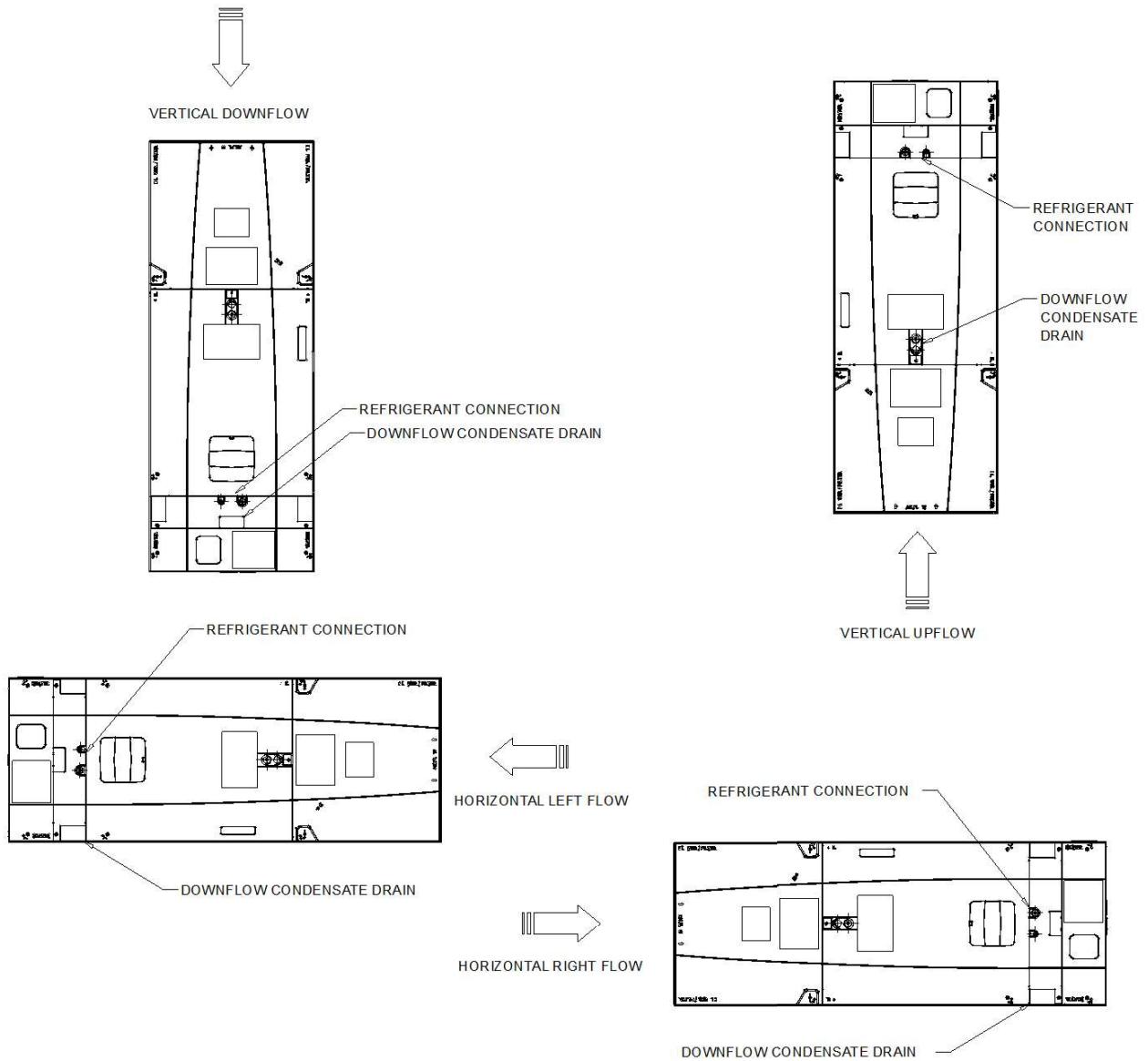

- NOTES**
1. NO INTERNAL MODIFICATIONS REQUIRED FOR ANY POSITION.
 2. BADGE ROTATION WILL BRAND IN CORRECT POSITION.

MINIMUM UNIT CLEARANCE TABLE		
	TO COMBUSTIBLE MATERIALS (REQUIRED)	SERVICE CLEARANCE (RECOMMENDED)
SIDE	0	2"
FRONT	0	21"
BACK	0	0
INLET DUCT	0	0
OUTLET DUCT	0	0

CLEARANCE NOTES:
 * 1" FOR THE FIRST 3 FT. OF OUTLET DUCT
 WHEN ELECTRIC HEATERS ARE INSTALLED EXCEPT
 MODELS BAYHTR1405, 1408, AND 1410 ARE APPROVED FOR
 0" PLENUM AND DUCT CLEARANCE IN THE UPFLOW
 CONFIGURATION ONLY ON TWE-P MODELS.

Field Installed Options - Part/Order Number Summary

This is a report to help you locate field installed options that arrive at the jobsite. This report provides part or order numbers for each field installed option, and references it to a specific product tag. It is NOT intended as a bill of material for the job.

Product Family - Split System Air Conditioning Units (Small)

Item	Tag(s)	Qty	Description	Model Number
A1	AHU-HP-1	1	1.5 - 5 Ton Unitary Split Systems (SSC)	5TWR7048A1 - 5TAM5D06AC41S
A2	AHU-HP-2	1	1.5 - 5 Ton Unitary Split Systems (SSC)	5TWR7048A1 - 5TAM5D07AC51S

Field Installed Option Description	Part/Ordering Number
Touchscreen Programmable Thermostat, 4H/2C	TCONT302AS42DA
2.88/3.84 kW Heater 208/240/60/1	BAYEA1304LG1AA