

# QT048

## Liquid Cooled Gas Engine Generator Sets

Standby Power Rating  
48 kW 60 Hz

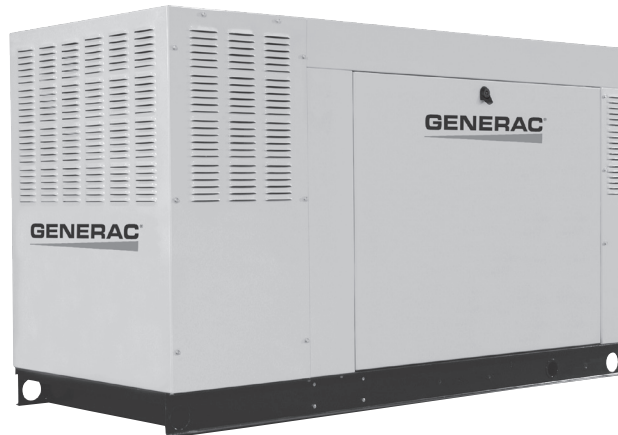

### GENERAC 4.2L ENGINE

Naturally Aspirated  
Gaseous Fueled  
Meets 2009 EPA Emission Regulations

## STANDARD EQUIPMENT

- All input connections in one single area
- High coolant temperature shutdown
- Low oil pressure shutdown
- Low coolant level automatic shutdown
- Overspeed automatic shutdown
- Crank timer
- Exercise timer
- Oil drain extension
- Cool flow radiator
- Closed coolant recovery system
- UV/Ozone resistant hoses
- Watertight state of the art electrical connectors
- Mainline circuit breaker
- Radiator drain extension
- Battery charge alternator
- 2 Amp static battery charger
- Battery cables
- Battery rack
- Fan and belt guards
- Isochronous governor
- Flex fuel line
- Hour meter

## FEATURES

- Innovative design and fully prototype tested
- UL2200 Listed
- Solid state frequency compensated voltage regulator
- Dynamic and static battery charger
- Sound attenuated acoustically designed enclosure
- Quiet test for low noise level exercise
- Acoustically designed engine cooling system
- High flow low noise factory engineered exhaust system
- State of the art digital control system with R100 digital control panel
- Watertight electrical connectors
- Rodent proof construction
- High efficiency, low distortion Generac designed alternator
- Vibration isolated from mounting base
- Matching Generac transfer switches engineered and tested to work as a system
- All components easily accessible for maintenance
- Electrostatically applied powder paint

# GENERAC®

# APPLICATION & ENGINEERING DATA

QT048

## GENERATOR SPECIFICATIONS

TYPE .....	Synchronous
ROTOR INSULATION.....	Class H
STATOR INSULATION.....	Class H
TOTAL HARMONIC DISTORTION.....	<5%
TELEPHONE INTERFERENCE FACTOR (TIF) .....	<50
ALTERNATOR OUTPUT LEADS 3 PHASE .....	4 wire
BEARINGS.....	Sealed Ball
COUPLING.....	Flexible Disc
LOAD CAPACITY (STANDBY RATING).....	48 kW
EXCITATION SYSTEM.....	Direct

**NOTE: Generator rating and performance in accordance with ISO8528-5, BS5514, SAE J1349, ISO3046, and DIN6271 standards.**

## VOLTAGE REGULATOR

TYPE .....	Electronic
SENSING .....	Single Phase
REGULATION.....	± 1%
FEATURES.....	V/F Adjustable Adjustable Voltage and Gain LED Indicators

## GENERATOR FEATURES

- Revolving field heavy duty generator
- Directly connected to the engine
- Operating temperature rise 120 °C above a 40 °C ambient
- Insulation is Class H rated at 150 °C rise
- All models are fully prototyped tested

## CONTROL PANEL FEATURES

- |  |  |
|--|--|
| <input type="checkbox"/> SEVEN LED INDICATOR LIGHTS <ul style="list-style-type: none"><li>• System ready</li><li>• Low fuel pressure</li><li>• Low battery</li><li>• Low oil pressure</li><li>• High coolant temp/low coolant temp</li><li>• Overspeed</li><li>• Overcrank</li></ul> | <input type="checkbox"/> ADDITIONAL FUNCTIONS <ul style="list-style-type: none"><li>• Utility sensing</li><li>• Delay on utility failure for engine start</li><li>• Engine warm-up before transfer</li><li>• Delay to retransfer to utility</li><li>• Engine cooldown timer</li><li>• Exerciser not set</li><li>• Hour meter</li></ul> |
|--|--|
- INTERNAL FUNCTIONS:
- 3 position switch (auto, off and manual)
  - 2 wire start for any transfer switch
  - Communicates with the Generac RTS transfer switch
  - Built-in 7 day exerciser
  - Selectable engine speed at exercise
  - Governor controller is built into the master control board
  - Temperature range -40 °C to 70 °C

## ENGINE SPECIFICATIONS

MAKE .....	Generac
MODEL.....	V6
CYLINDERS.....	6
DISPLACEMENT.....	4.2 Liter
BORE (inches) .....	3.81
STROKE (inches).....	3.74
COMPRESSION RATIO.....	9.3:1
INTAKE AIR SYSTEM.....	Naturally Aspirated
VALVE SEATS (Int. & Exh.) .....	Precision ground and hardened
LIFTER TYPE.....	Roller, Hydraulic

## GOVERNOR SPECIFICATIONS

TYPE .....	Electronic
FREQUENCY REGULATION.....	Isochronous
STEADY STATE REGULATION.....	± 0.25%

## ENGINE LUBRICATION SYSTEM

OIL PUMP .....	Gear
OIL FILTER.....	Full flow spin-on cartridge
CRANKCASE CAPACITY.....	6 Quarts

## ENGINE COOLING SYSTEM

TYPE .....	Pressurized Closed
WATER PUMP FLOW.....	10.8 gal/min
FAN SPEED .....	1050
FAN DIAMETER.....	22 inches
FAN MODE.....	Puller

## FUEL SYSTEM

FUEL TYPE.....	Natural gas, propane vapor
CARBURETOR.....	Down Draft
SECONDARY FUEL REGULATOR.....	Standard
FUEL SHUT OFF SOLENOID .....	Standard
OPERATING FUEL PRESSURE.....	5" - 14" H <sub>2</sub> O

## ELECTRICAL SYSTEM

BATTERY CHARGE ALTERNATOR.....	12V 30 Amp
STATIC BATTERY CHARGER .....	2 Amp
RECOMMENDED BATTERY .....	Group 24F, 525CCA
SYSTEM VOLTAGE.....	12 Volts

QT048

## OPERATING DATA

		QT048				
<b>KW RATING</b>		48				
<b>ENGINE SIZE</b>		4.2 Liter				
<b>GENERATOR OUTPUT VOLTAGE/KW - 60Hz</b>		<b>kW - LP</b>	<b>Amps</b>	<b>kW - NG</b>	<b>Amps</b>	<b>CB Size</b>
120/240V, 1-phase, 1.0 pf		48	200	46	192	200
120/208V, 3-phase, 0.8 pf		48	166	46	160	175
120/240V, 3-phase, 0.8 pf		48	144	46	138	150
277/480V, 3-phase, 0.8 pf		48	72	46	69	80
<b>GENERATOR LOCKED ROTOR KVA AVAILABLE @ VOLTAGE DIP OF 35%</b>						
Single phase or 208 3-phase		100				
480V 3-phase		110				
<b>ENGINE FUEL CONSUMPTION (Natural Gas) (Propane)</b>		<b>Natural Gas</b>		<b>Propane</b>		
		(ft <sup>3</sup> /hr.)	(gal/hr.)	cu ft/hr		
Exercise cycle		88	0.94	34.4		
25% of rated load		205	2.23	81		
50% of rated load		370	4.03	147		
75% of rated load		516	5.62	204		
100% of rated load		661	7.20	261		
<b>ENGINE COOLING</b>						
Air flow (inlet air including alternator and combustion air)	ft <sup>3</sup> /min.	2,460				
System coolant capacity	US gal.	3.0				
Heat rejection to coolant	BTU/hr.	165,000				
Max. operating air temp. on radiator	°C (°F)	60 (150)				
Max. ambient temperature	°C (°F)	50 (140)				
<b>COMBUSTION AIR REQUIREMENTS</b>						
Flow at rated power 60 Hz	cfm	235				
<b>SOUND EMISSIONS IN DBA</b>						
Exercising at 7 meters		60				
Normal operation at 7 meters		65				
<b>EXHAUST</b>						
Exhaust flow at rated output 60 Hz	cfm	395				
Exhaust temp. at muffler outlet	°F	1100				
<b>ENGINE PARAMETERS</b>						
Rated synchronous RPM	60 Hz	1800				
HP at rated KW	60 Hz	75				
<b>POWER ADJUSTMENT FOR AMBIENT CONDITIONS</b>						
Temperature Deration						
3% for every 10 °C above - °C		25				
1.65% for every 10 °F above - °F		77				
Altitude Deration						
1% for every 100 m above - m		183				
3% for every 1000 ft. above - ft.		600				

RATING: All three phase units are rated at 0.8 power factor. All single phase units are rated at 1.0 power factor. STANDBY RATING: Standby ratings apply to installations served by a reliable utility source. The standby rating is applicable to varying loads for the duration of a power outage. There is no overload capability for this rating. Ratings are in accordance with ISO-3046-1, BS5514, and DIN6271. Maximum wattage and current are subject to and limited by such factors as fuel Btu content, ambient temperature, altitude, engine power and condition. Design and specifications are subject to change without notice.

KW rating is based on LPG Fuel and may derate with natural gas.

# INTERCONNECTIONS

QT048

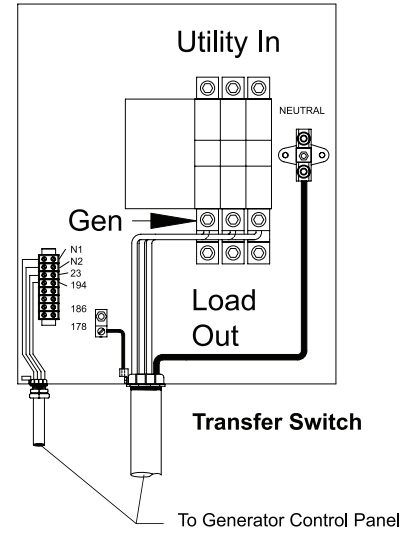
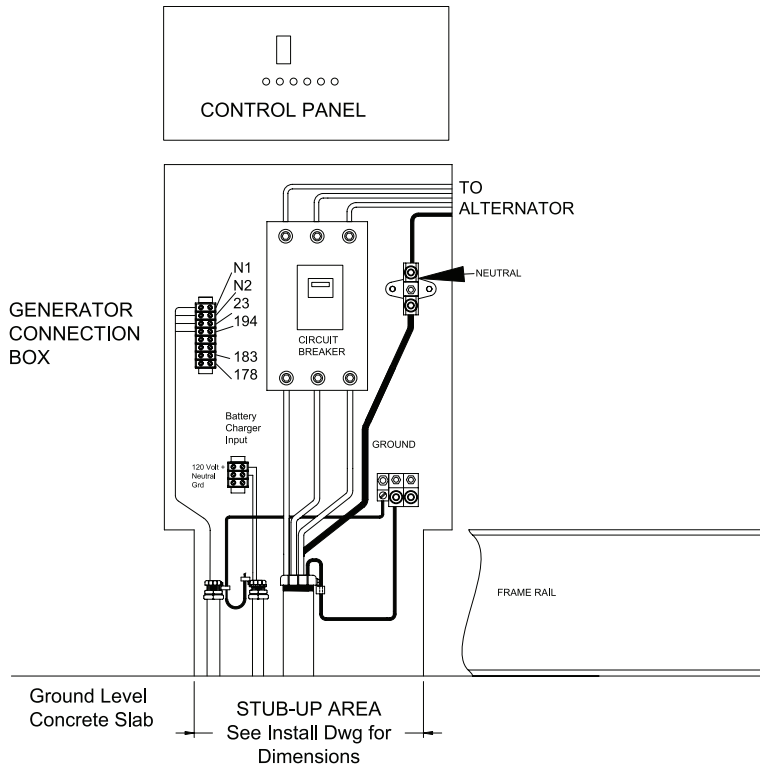

### CIRCUIT BREAKER SIZE

KW	VOLTS	AMPS	LUG SIZE
48/46	240 1Ø	200	#6 to 300 mcm
48/46	208 3Ø	175	#6 to 300 mcm
48/46	240 3Ø	150	#6 to 300 mcm
48/46	480 3Ø	80	#6 to 300 mcm

Installation Drawing Ref. No. 0G5868

# INSTALLATION LAYOUT

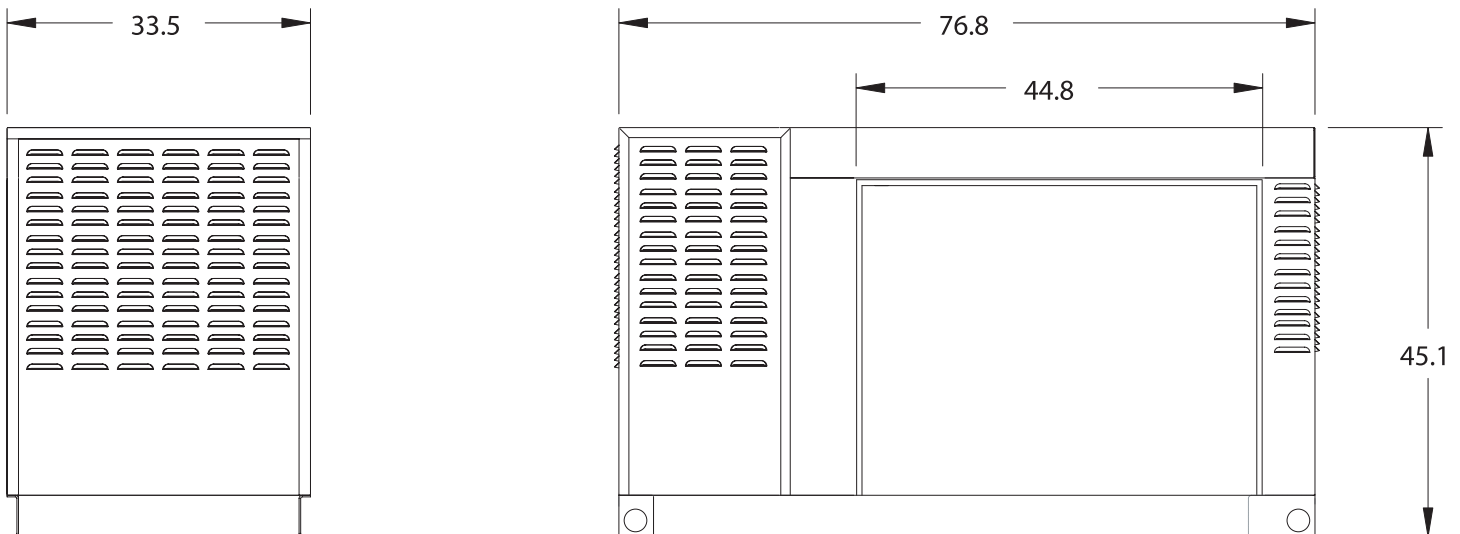

**WEIGHT: 1740 lbs.**



Generac Power Systems, Inc. • S45 W29290 HWY. 59, Waukesha, WI 53189 • generac.com

©2009 Generac Power Systems, Inc. All rights reserved. All specifications are subject to change without notice. Bulletin 0177730SBY/Printed in U.S.A.06.08, rev. 03.09