

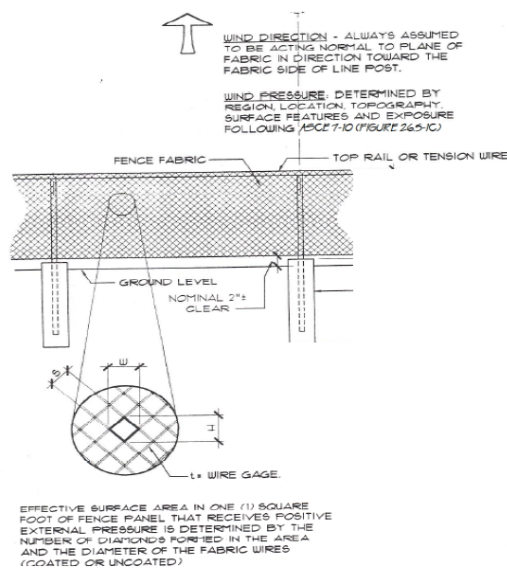

**CHAIN LINK FENCE
MANUFACTURERS INSTITUTE**

CHAIN LINK FENCE WIND LOAD GUIDE FOR THE SELECTION OF LINE POST AND LINE POST SPACING

(WLG 2445)



Revised June, 2014

Copyright (C) 2014 **Chain Link Fence Manufacturers Institute** All Rights Reserved.

10015 Old Columbia Road Suite B215
Columbia, MD 21046
Ph: 301-596-2583 Fax: 301-596-2594
Email: clfmihq@aol.com
www.chainlinkinfo.org



CLFMI Technical Support Team

To get answers to your questions regarding the content or usage of the information contained in this publication, contact one of these fence industry professionals for assistance.

BILL ULLRICH	email: bullrich.link@comcast.net	Phone: 410-849-2610
CHUCK NAEGELE	email: canaegele@aol.com	Phone: 570-586-7260
STEVE PETERS	email: smpeters@ldpeters.com	Phone: 914-576-5100
TED EYSENBACH	email: teyzen@spsfence.com	Phone: 1-800-451-2612
DON FINN	email: dfinn@westerntube.com	Phone: 310-537-6300
TOM STANEK	email: tom.stanek@wheatland.com	Phone: 1-800-257-8182
BILL PETERSON	email: bill@richardsfence.com	Phone: 330-773-0423

Published by:

Chain Link Fence Manufacturers Institute (CLFMI)
10015 Old Columbia Road • Suite B-215 • Columbia, MD 21046
Phone: (301) 596-2583 • Fax: (301) 596-2594
E-mail: info@chainlinkinfo.org
Website: www.chainlinkinfo.org

DISCLAIMER

The Wind Load Guide for the Selection of Line Post Spacings for Woven Wire Chain Link Fencing is published by the Chain Link Fence Manufacturers Institute as a general information service in the selection of spacing for fencing line posts for chain link fence systems. However, because exposure, workmanship, soils, drainage, emplacement problems, wind and other weather conditions may vary, even at various locations in a single site, each application should be assessed by a qualified professional engineer. Accordingly, no representation or warranty is made, and none should be implied, respecting the suitability or adequacy of the information in this Guide for any particular application, nor is this Guide intended to establish industry "standards" respecting the selection of spacing for fencing line posts, or for any purpose.

TABLE OF CONTENTS

• Introduction	1
• Factors Which Influence the Size and Spacing of Line Posts	2
• Figure 1, Line Post Spacing Details	3
• Methodology	4 to 5
• How to Use the Guide.....	6
• Examples.....	7 to 9
• Tables	10 to 22
• Table 1; Line Post Selection Guide for 105 MPH Wind	
• Table 2; Line Post Selection Guide for 110 MPH Wind	
• Table 3; Line Post Selection Guide for 120 MPH Wind	
• Table 4; Line Post Selection Guide for 130 MPH Wind	
• Table 5; Line Post Selection Guide for 140 MPH Wind	
• Table 6; Line Post Selection Guide for 150 MPH Wind	
• Table 7; Line Post Selection Guide for 160 MPH Wind	
• Table 8; Line Post Selection Guide for 170 MPH Wind	
• Table 9; Mesh and Fabric Size Coefficients "Cf1"	
• Table 10; Wind Exposure Category Coefficients "Cf2"	
• Table 11; Ice Exposure Effect Probability Coefficients "Cf3"	
• Table 12; Line Post Material Properties Table	
• Table 13; Wind Speed / Velocity Pressure Table	
• Figure 26.5-1C, Minimum Basic Wind Speeds Map.....	23 to 24
• Appendix	25 to 32
• References	33

INTRODUCTION

The Chain Link Fence Manufacturers Institute (CLFMI) would like to acknowledge Leonard Engineering, Inc. for the technical analysis of this Guide, as well as members of the CLFMI Technical Committee, for their complete and thorough editing effort on the original version. Also, further acknowledgement is extended to the American Society of Civil Engineers (ASCE) for agreeing to the use of its copyrighted materials, CLFMI wishes to extend special recognition to Charles Naegele, Chair of the CLFMI Technical Committee, for his leadership in the production of this Guide.

This Guide is intended to provide background information in the forms of charts and tables to assist fence designers and installers in the appropriate selection of fencing line posts for chain link fencing. However, because conditions vary from site to site, the information in the Guide should not be relied upon without the evaluation of a qualified professional engineer.

PLEASE READ THE DISCLAIMER.

The Guide includes eight tables for the spacings of line posts exposed to wind speeds of 105 MPH up to and including 170 MPH. These tables are based on the applicable ASCE 7-10 wind load standards. The spacing values listed in the eight tables must be adjusted using appropriate and selected coefficients to account for the size of the fabric gauge and mesh size, wind exposure and the probability for the development of icing conditions at that location. Moreover, the tables do not take into account wind speeds exceeding 170 MPH, which may occur in category 5 hurricanes, tornadoes, at high elevations, or as the result of explosions.

Seven of the more commonly used fabric wire gage sizes and seven of the most commonly used mesh sizes when used in any combination and acted upon by the several sets of wind pressures (not wind speed or velocity) offers the user choices in the selection and/or specifying line posts based on local wind conditions, economics, aesthetics and functionality of other design criteria established for a specific application. It should be noted that this guide is specifically designed for the use with chain link fence systems only and is not intended for use with other fence designs.

The guide considers the following assumptions as being applicable in the design analysis based on the wind loading criteria outlined in **ASCE 7-10, "Minimum Load Design Criteria for Buildings and Other Structures", Chapter 26, Wind Loads: General Requirements and Chapter 29, Wind Loads on Other Structures and Building Appurtenances—MWFRS.**

- Wind is acting in a direction normal to the plane of the fencing fabric and applied on the fabric side of the line post.
- Tension wire or rail at the base and top of the fence accommodates the normal tensile loading being applied to take up vertical sag of the fence.

Additionally the line posts are considered to be embedded in the ground surface in accordance with the minimum size and depth established according to the **2009 International Building Code and ASTM F567, "Standard Practice for Installation of Chain Link Fence"**. All posts are considered to be embedded in concrete, minimum 2,500 psi, air-entrained, of a depth consistent with local soil types and conditions.

FACTORS WHICH INFLUENCE THE SIZE AND SPACING OF LINE POSTS*

- HEIGHT OF FENCE** The height of the fence influences the actual amount of wind force that must be resisted by the post and the required anchorage to the ground. The fence height times the line post spacing sets the total force acting on a solid panel of the fence which is transferred to the line posts and then into the footing.
- STYLE AND SIZE OF FABRIC** The style and size of fabric determines the net surface area of the solid fence panel exposed to the wind pressure which in turn must possess adequate tensile strength to transfer the developed loading to the supporting members of the fence assembly; i.e., line posts, top rail and base tension wire.
- MATERIAL STRENGTH AND SHAPE OF POST** Material strength and shape of post determines the size of posts and their spacing which will provide the required resistance to the maximum expected wind forces that may develop over the anticipated normal life-span of the installation and to remain serviceable subsequent to the maximum wind event.
- UPDATED FOOTING ANALYSIS AS RELATED TO SOIL TYPE AND BEARING LOADS** The type of soil that will be encountered at the site of the fence installation will influence the post size and spacing by way of the passive soil pressures that can reasonably be expected to resist the tendency for the line posts to overturn and also to remain in an essentially plumb position after the wind event. For footing design criteria, it is advisable to contact a competent geotechnical professional for the appropriate soils information at the particular site. The minimum depth of footings in accordance with **ASTM F567** is 24" plus an additional 3" for each one (1) foot of fence height over 4 feet. The **2009 International Building Code, (Eq. 18-1)** is utilized to determine the required footing embedment depth, up to a maximum embedment depth of 12'-0" below finish grade

VARIABLES AND DEFINITIONS for the FORMULA FOR DETERMINING FOOTING DEPTH

- P** = Resultant concentrated wind force applied to post **d** = Diameter of post footing
c = Distance above top of footing at which "P" is applied to post **S1** = Allowable lateral soil-bearing pressure
D = Post footing embedment depth below finish grade **H** = Fence post height above top of footing

$$D = 0.5A * \{ 1 + [(4.36 * H) / A]^{1/2} \}$$

$$A = 2.34P/S1*d$$

SEE THE CALCULATION EXAMPLE 3 ON PAGE (8) FOR AN ILLUSTRATION OF THIS ANALYSIS

The table listed below (which is also found on page 32 of this Guide) shows the Presumptive Soil Load Bearing Values for calculations to determine footing sizes using this updated approach, which includes lateral as well as vertical factors.

TABLE 1806.2
PRESUMPTIVE LOAD-BEARING VALUES

CLASS OF MATERIALS	VERTICAL FOUNDATION PRESSURE (pst)	LATERAL BEARING PRESSURE (psf/ft below natural grade)	LATERAL SLIDING RESISTANCE	
			Coefficient of friction ^a	Cohesion (psf)b
1. Crystalline bedrock	12,000	1,200	0.70	-
2. Sedimentary and foliated rock	4,000	400	0.35	-
3. Sandy gravel and/or gravel (GW and GP)	3,000	200	0.35	-
4. Sand, silty sand, clayey sand, silty gravel and clayey gravel (SW, SP, SM, SC, GM and GC)	2,000	150	0.25	-
5. Clay, sandy clay, silty clay, clayey silt, silt and sandy silt (CL, ML, MH and CH)	1,500	100	-	130

For SI: 1 pound per square foot = 0.0479 kPa. 1 pound per square foot per foot = 0.157 kPa/m.

a. Coefficient to be multiplied by the dead load.

b. Cohesion value to be multiplied by the contact area, as limited by Section 1806.3.2.

- WIND PRESSURE** Wind pressure is the most dominant factor that influences the post size and spacing since it is the only force that can reasonably be predicted and will be acting on the posts under normal conditions. Reference Table 13 for values of various wind speeds and pressures. Wind pressure in itself is further influenced by other factors; i.e., geographical region, exposure, topography and ground surface features in the local area.

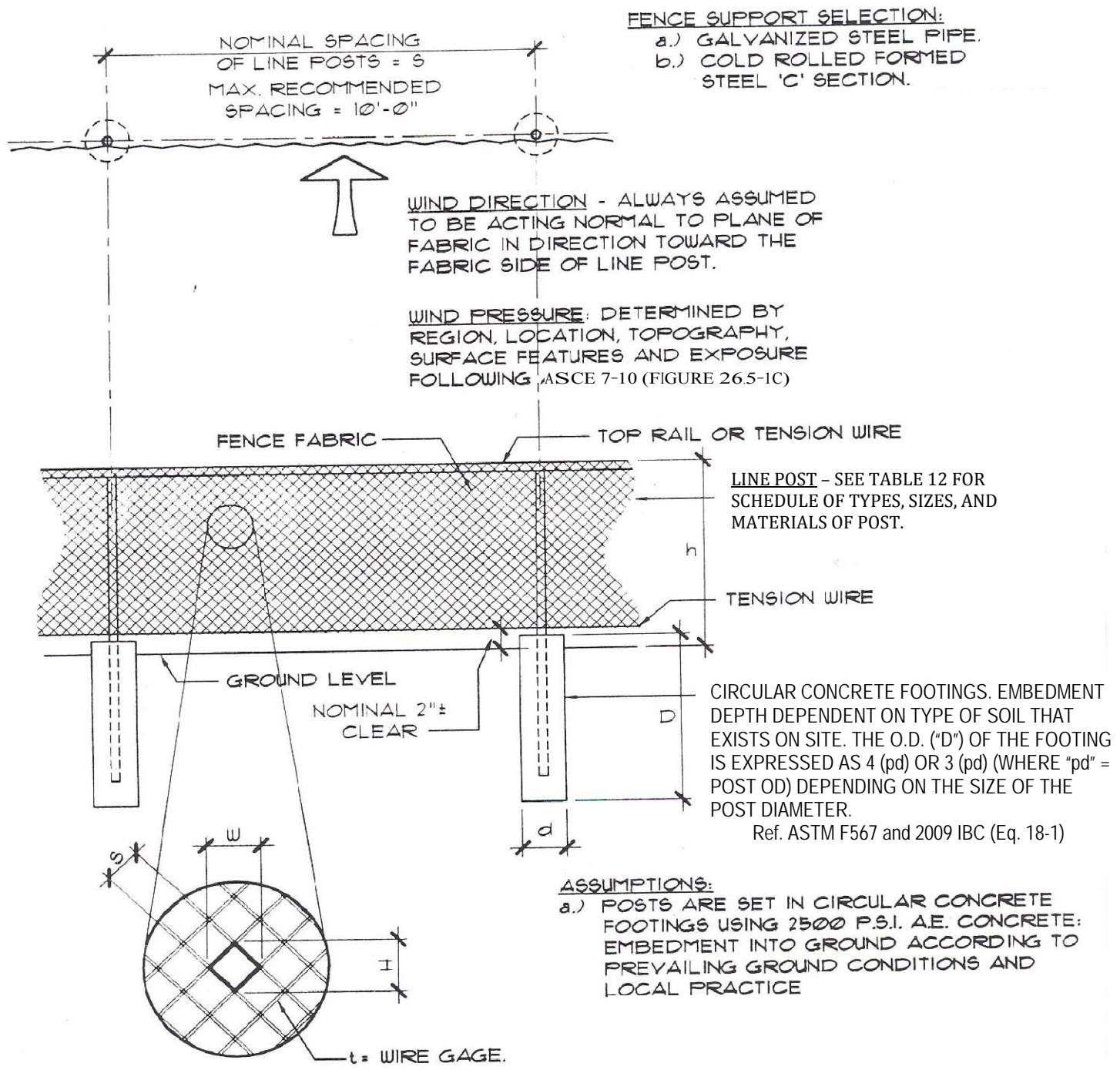

EFFECTIVE SURFACE AREA IN ONE (1) SQUARE FOOT OF FENCE PANEL THAT RECEIVES POSITIVE EXTERNAL PRESSURE IS DETERMINED BY THE NUMBER OF DIAMONDS FORMED IN THE AREA AND THE DIAMETER OF THE FABRIC WIRES (COATED OR UNCOATED)

FIGURE #1
LINE POST SPACING GUIDE DETAILS

METHODOLOGY

The methodology applied to develop the tabular values of "S", the unmodified maximum spacings of line post materials, sizes and shapes most commonly employed in the chain link fencing industry, for the fence heights and wind speeds was based on wind loading criteria outlined in **ASCE 7-10, Chapter 26, Wind Loads: General Requirements and Chapter 29, Wind Loads on Other Structures and Building Appurtenances—MWFRS**, excerpts of which are included in the Appendix of this Guide.

This application of the recommended loading criteria as it applies to fence construction takes into consideration all factors that influence the wind forces applied to the primary force resisting element of the fence; in this instance the line posts, which in-turn must transfer that loading to the ground. This guide is based on the assumption of a solid panel of fencing and uses multiplication factors for various percentages of free area of the fence panel.

To establish the magnitude of the wind force that will be acting on the line post, it must first be established what the net surface area of the fence panel will be; i.e., the solid panel area, "h x S" less the void spaces within the fence. The net surface area of the wire fabric is what the wind force impinges on and is directed on to the post. Since the panel of the fence is essentially a perforated plane, it is necessary to quantify the actual solid surface to void area. The area of wire surface was determined by establishing the number of diamonds in a square foot of fabric and totaling the length of wire in that area. This is the value used in combination with the computed wind velocity pressures that when applied as a load to the fence post acting as a flagpole design; i.e., a vertical cantilever, fixed at its base to the footing and ground.

Now with the value known for the wind velocity pressure that develops for each of the selected ranges of the eight Wind Speed Classes of 105 MPH through 170 MPH acting under normal conditions for a Wind Exposure Category "B", these forces are then applied to the face area of the fence panel assumed to be solid. With the height "H" of the fence known, the only variable that needs to be established to set the total gross area "A_g" of the panel is the line post spacing "S". The values of "S" were generated based on the loading applied to the post as a vertical cantilever, in a similar fashion as the "classic" flagpole design.

Table 1 through **Table 8** are set up for fence heights that range from 3 feet up to and including 20 feet and twenty-six combinations of line post sizes and types, in a solid panel configuration. The "S" values were computed on the basis of their physical, material properties and formulas listed in **Table 12** with a limiting value based on the maximum allowable stress.

To account for the variations in the fabric wire sizes and sizes of mesh, **Table 9** was developed and lists the Coefficient "C_{f1}" which accounts for the variation and is based on a ratio of net area to gross area of a solid panel for each of the commonly used styles employed in the industry.

The base program for the line post spacing was set up using the condition where Wind Exposure Category "B" is the normal situation. To account for the other two Wind Exposure Categories, "C" and "D", **Table 10** was developed to list the Coefficient "**Cf₂**" which is a ratio of the Wind Exposure Coefficient "**K_z**" for Exposure "B" to the other two exposure coefficients as listed in **ASCE 7-10, Table 29.3-1**.

In **Table 11**, Ice Effect Probability Coefficient "**Cf₃**" is included in the guide and was set up using arbitrary values to permit the designer the ability to make an intelligent decision relative to his perception and experience as to the probability that a severe icing condition may develop concurrent with the listed maximum wind speed for that particular geographical location for non-solid fencing.

Figure 26.5-1C from **ASCE 7-10** shows wind speed categories in the range of 105 MPH to 170 MPH, but also includes special wind speed regions and a 180 MPH wind speed for use in Guam. This guide provides values of wind speeds that cover the entire range of velocities that may be encountered in the continental United States and Hawaii but does not include Guam and will require separate analysis to determine wind speeds in the special wind speed regions as determined by local jurisdictions and/or case study. For any installations determined to have intermediate wind speeds, it is acceptable to interpolate linearly.

The user of this guide is advised that he may want to consider use of the full allowable stress of the material being employed which has a built-in Factor of Safety equivalent to 1.5; ie., $0.66 F_y$, **Reference Table 12**. The user may also want to consider the merits of using a higher maximum allowable stress increase due to the fact that wind loadings usually may not be a sustained condition for that specific location where the fence installation is being planned.

HOW TO USE THE GUIDE

For the fence fabric configuration and size of line post being considered, go to the appropriate table (Table 1,2,3, ,8) that closely agrees with the maximum anticipated wind speed designated by the local codes for that geographical area where the fence installation is planned. From that table, find the value of “**S**” for the line post size and height desired. This value of “**S**” must then be multiplied by correction coefficients that account for the type, size and mesh of the wire fabric, “**Cf1**” from **Table 9**; Wind exposure category coefficient, “**Cf2**” from **Table 10**; Icing effects probability coefficient, “**Cf3**” from **Table 11**.

The recommended post spacing **S' = S X Cf1 x Cf2 x Cf3**

EXAMPLE I:

Select a line post spacing for a 10' high Chain Link fence, constructed of #9 gage wire, having a mesh size pattern of 1-3/4". The installation location is for a park in an urban location in the Eastern U. S., where the wind exposure is considered “ Exposure C “. Assume the local governing code indicates that the maximum wind speed for this application is 105 MPH; localized icing effects are considered to be moderate. One possible line post material selection for this example is Group 1A, Schedule 40 steel pipe.

From **Table 1, Wind Speed 105 MPH**, for a **4.0**" outside diameter pipe, the listed “**S**” value for a 10' high fence is **3.6**.

From **Table 9**, the Coefficient “**Cf1**”, for a #9 gage, 1-3/4" mesh fabric = **6.4**

From **Table 10**, the Coefficient “**Cf2**”, for a Wind Exposure Category C = **0.67**

From **Table 11**, the Coefficient “**Cf3**”, for Moderate Icing Effects = **0.85**

Thus the recommended maximum spacing for the 4" outside diameter Schedule 40, steel pipe post for the 10' high fence with a #9 gage wire and 1-3/4" mesh would be:

$$\mathbf{S' = S X Cf1 x Cf2 x Cf3 = 3.6 x 6.4 x 0.67 x 0.85 = 13.12'}$$

The maximum recommended spacing would be **10'-0" c/c** for the posts.

EXAMPLE2

For a situation where the Wind Velocity is other than for one of the eight listed tables of line post spacings in the guide:

Select a line post size and spacing for a 16' high chain link fence installation for which the fabric is to be a #9 gage - 1/2" mesh pattern. Assume the fence location is in an open terrain where the Wind Exposure Category is "C" and the code listed maximum wind speed is 115 MPH; icing effects potential is considered to be moderate.

From **Table 9**, the coefficient "**Cf1**" for mesh size and gage = **2.20**

From **Table 10**, the coefficient "**Cf2**" for wind exposure "**C**" = **0.69**

From **Table 11**, the coefficient "**Cf3**" for moderate icing effect = **0.85**

From **Table 2**, for a 110 MPH wind and a 16' high fence, select a Trial line post size spacing factor "**S**" = **4.8** for a Group IA, 6-5/8" OD steel pipe.

For this arrangement the maximum spacing would be the result of $4.8 \times 2.20 \times 0.69 \times 0.85 = 6.19'$; This may not be an economical or practical spacing.

Therefore try the spacing for a Group IA, 8-5/8" OD steel pipe where "**S**" = **9.70** whose maximum recommended spacing would be $9.70/4.8 \times 6.19' = 12.51'$.

Since the wind speed being evaluated is **115 MPH** condition the recommended spacing would be $110/115 \times 12.51' = 11.97'$ or **10'- 0" on centers**, which would be more consistent with the usual standard spacing followed in the industry.

EXAMPLE 3:

For a site location with a high wind condition and the design selection of an appropriate footing size and depth:

Select a line post size, its spacing and footing for a 12' high chain link fence that will consist of a #9 gage-1-3/4" mesh fabric. Installation will be in Southern Florida in an open terrain with a wind exposure category "C" and a maximum wind velocity of 150 MPH. Soil condition is assumed to be a silty sand (Actual soil properties should be established by a qualified geotechnical engineer familiar with local soil conditions).

From **Table 6** for 150 MPH wind and under 12' high fence and a trial size line post of Group IA, 4" outside diameter steel pipe "**S**" = **1.2**

"**Cf1**" for the fabric size and gage = **6.4**

"**Cf2**" for the wind exposure category = **0.67**

"**Cf3**" for icing condition = **1.0**

Thus the maximum spacing for the Group IA, 4" outside diameter pipe = $1.2 \times 6.4 \times 0.67 \times 1.0 = 5.14'$. This may not be an economical spacing; try another trial size post.

Checking the spacing for a Group IA, 6-5/8" outside diameter pipe where "**S**" = 4.6, maximum spacing will be $4.6/1.2 \times 5.14' = 19.7'$ use 10'-0".

For the 6-5/8" outside diameter line post, the minimum footing size is 3 x Pipe outside diameter per ASTM F567 or 19.9"; however, it is recommended that footing size of 30" diameter be used. The minimum depth of footing embedment in the silty sand soil is to be calculated as follows:

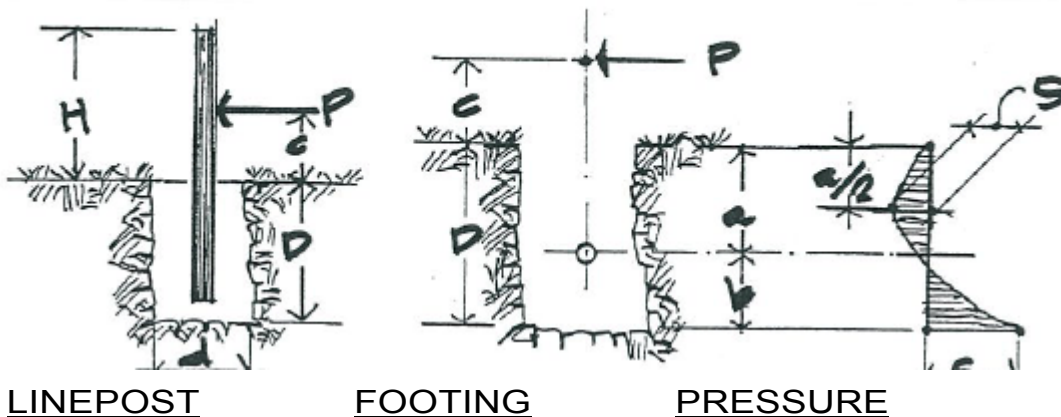

Allowable lateral soil bearing pressure (S_1) for silty sand = 150 psf *, as determined from the 2009 International Building Code Table 1806.2 Presumptive Soil Load-Bearing Values. See Appendix, pg. 32.

EXAMPLE3 (Continued):

Distance of applied force above footing "c" = $0.5H + 0.05H = 0.55 \times 12' = 6.60'$

Applied Force "P" = $(1/Cf1) \times \text{Net Area of Fence} \times \text{Wind Pressure}$ where Cf1 is the Mesh and Fabric Size Coefficient from Table 9 and the Wind Pressure is the Design Wind Pressure from Table 13.

$$P = (0.16 \text{ sf/sf}) (120 \text{ sf}) (30.84 \text{ lb/sf}) = 592 \text{ lbs}$$

Diameter of footing $d = 30" = 2.50'$

Solving for "D" $D = 0.5A * \{ 1 + [(4.36 * H) / A]^{1/2} \}$ (2009 IBC Eq. 18-1)

where $A = 2.34P/S1*d = 2.34 * (592 \text{ lbs }) / 150 \text{ psf } * 2.5$
 $= 3.69$

$$D = (0.5)(3.69) * \{ 1 + [4.36 * (12 / 3.69)]^{1/2} \}$$
$$= 8.79'$$

This required depth is less than the maximum embedment depth of 12.0' specified in the **2009 International Building Code** and also exceeds the minimum footing depth as set by **ASTM F567** which is $24" + [3" \times (12' - 4.0')] = 24" + 24" = 48"$. Therefore, the calculated depth is the preferred choice.

Use a footing depth of 9.0'

* Assumed allowable soil bearing pressure; actual value should be determined by appropriate means.

TABLE 1
LINE POST SELECTION: WIND SPEED 105 MPH
EXPOSURE CATEGORY "B"

LINE POST SIZE IN	LINE POST MAXIMUM SPACING, S (FEET) FOR USE IN EQUATION: $S' = S \times Cf1 \times Cf2 \times Cf3$ FENCE HEIGHT (FEET)																			
	3	3.5	4	5	6	7	8	9	10	11	12	13	14	15	16	17	18	19	20	
	Group IA: (ASTM F1043) Schedule 40 Steel Pipe, ASTM F1083 Regular Grade (30,000 psi yield)																			
1 7/8"	5.5	4.0	3.0	1.9	1.2	----	----	----	----	----	----	----	----	----	----	----	----	----	----	
2 3/8"	9.6	7.0	5.3	3.4	2.3	1.6	1.2	----	----	----	----	----	----	----	----	----	----	----	----	
2 7/8"	18.1	13.3	10.2	6.5	4.4	3.2	2.4	1.9	1.5	1.2	----	----	----	----	----	----	----	----	----	
3 1/2"	29.5	21.8	16.6	10.6	7.3	5.3	4.0	3.2	2.5	2.0	1.7	1.4	1.2	----	----	----	----	----	----	
4"	41.0	30.1	23.0	14.7	10.2	7.5	5.7	4.4	3.6	2.9	2.4	2.0	1.7	1.5	1.2	1.1	----	----	----	
6 5/8"	----	----	----	52.5	36.4	26.8	20.5	16.2	13.1	10.8	9.0	7.7	6.6	5.7	5.0	4.4	3.9	3.5	3.1	
8 5/8"	----	----	----	----	----	53.0	40.5	32.0	25.9	21.4	18.0	15.3	13.2	11.5	10.1	8.9	7.9	7.1	6.4	
GROUP IA: (ASTM F1043) Schedule 40 Steel Pipe, ASTM F1083 High Strength Grade (50,000 psi yield strength)																				
1 7/8"	9.2	6.7	5.0	3.2	2.0	----	----	----	----	----	----	----	----	----	----	----	----	----	----	
2 3/8"	16.0	11.7	8.8	5.7	3.8	2.7	2.0	----	----	----	----	----	----	----	----	----	----	----	----	
2 7/8"	30.2	22.2	17.0	10.8	7.3	5.3	4.0	3.2	2.5	2.0	----	----	----	----	----	----	----	----	----	
3 1/2"	49.2	36.0	27.7	17.7	12.2	8.8	6.7	5.3	4.2	3.3	2.8	2.3	2.0	----	----	----	----	----	----	
4"	68.3	50.2	38.3	24.5	17.0	12.5	9.5	7.3	6.0	4.8	4.0	3.3	2.8	2.5	2.0	1.8	----	----	----	
6 5/8"	----	----	----	----	60.7	44.7	34.2	27.0	21.8	18.0	15.0	12.8	11.0	9.5	8.3	7.3	6.5	5.8	5.2	
8 5/8"	----	----	----	----	----	----	67.5	53.3	43.2	35.7	30.0	25.5	22.0	19.2	16.8	14.8	13.2	11.8	10.7	
GROUP IC: (ASTM F1043) Steel Pipe (50,000 psi yield)																				
1 5/8"	5.5	3.9	3.0	1.8	1.1	----	----	----	----	----	----	----	----	----	----	----	----	----	----	
1 7/8"	7.9	5.8	4.3	2.7	1.7	1.2	----	----	----	----	----	----	----	----	----	----	----	----	----	
2 3/8"	13.9	10.1	7.7	4.9	3.3	2.3	1.7	1.2	----	----	----	----	----	----	----	----	----	----	----	
2 7/8"	25.0	18.4	14	8.9	6.1	4.4	3.3	2.5	2.0	1.5	1.2	----	----	----	----	----	----	----	----	
3 1/2"	38.3	28.1	21.5	13.7	9.5	6.9	5.2	4.0	3.2	2.6	2.1	1.7	1.4	1.2	----	----	----	----	----	
4"	50.9	37.4	28.6	18.3	12.6	9.2	7.0	5.5	4.4	3.6	2.9	2.4	2.0	1.7	1.5	1.2	1.1	----	----	
GROUP II: (ASTM F1043) High Strength Cold Rolled Formed C-Shape (50,000 psi yield)																				
1 7/8" x 1 5/8" x .105	5.9	4.3	3.3	2.0	1.3	----	----	----	----	----	----	----	----	----	----	----	----	----	----	
1 7/8" x 1 5/8" x .121	10.0	7.3	5.6	3.5	2.3	1.6	1.2	----	----	----	----	----	----	----	----	----	----	----	----	
2 1/4" x 1 5/8" x .121	11.6	8.5	6.4	4.0	2.7	1.9	1.3	----	----	----	----	----	----	----	----	----	----	----	----	
3 1/4" x 2 1/2" x .130	26.6	20.9	15.8	9.9	6.6	4.6	3.2	2.3	1.6	1.1	----	----	----	----	----	----	----	----	----	

See Table 12 for post dimensions and material properties.

TABLE 2
LINE POST SELECTION: WIND SPEED 110 MPH
EXPOSURE CATEGORY "B"

LINE POST SIZE IN	LINE POST MAXIMUM SPACING, S (FEET) FOR USE IN EQUATION: $S' = S \times Cf1 \times Cf2 \times Cf3$ FENCE HEIGHT (FEET)																			
	3	3.5	4	5	6	7	8	9	10	11	12	13	14	15	16	17	18	19	20	
	Group IA: (ASTM F1043) Schedule 40 Steel Pipe, ASTM F1083 Regular Grade (30,000 psi yield)																			
1 7/8"	5.3	3.9	2.9	1.8	1.2	----	----	----	----	----	----	----	----	----	----	----	----	----	----	
2 3/8"	9.2	6.8	5.1	3.2	2.2	1.6	1.1	----	----	----	----	----	----	----	----	----	----	----	----	
2 7/8"	17.5	12.8	9.8	6.2	4.3	3.1	2.3	1.8	1.4	1.1	----	----	----	----	----	----	----	----	----	
3 1/2"	28.4	20.9	16.0	10.2	7.0	5.1	3.9	3.0	2.4	2.0	1.6	1.3	1.1	----	----	----	----	----	----	
4"	39.6	29.0	22.2	14.2	9.8	7.2	5.5	4.3	3.4	2.8	2.3	1.9	1.6	1.4	1.2	1.0	----	----	----	
6 5/8"	----	----	----	50.7	35.2	25.8	19.7	15.6	12.6	10.4	8.7	7.4	6.4	5.5	4.8	4.3	3.8	3.4	3.0	
8 5/8"	----	----	----	----	----	51.1	39.1	30.9	25.0	20.6	17.3	14.8	12.7	11.1	9.7	8.6	7.6	6.8	6.2	
GROUP IA: (ASTM F1043) Schedule 40 Steel Pipe, ASTM F1083 High Strength Grade (50,000 psi yield strength)																				
1 7/8"	8.8	6.5	4.8	3.0	2.0	----	----	----	----	----	----	----	----	----	----	----	----	----	----	
2 3/8"	15.3	11.3	8.5	5.3	3.7	2.7	1.8	----	----	----	----	----	----	----	----	----	----	----	----	
2 7/8"	29.2	21.3	16.3	10.3	7.2	5.2	3.8	3.0	2.3	1.8	----	----	----	----	----	----	----	----	----	
3 1/2"	47.3	34.8	26.7	17.0	11.7	8.5	6.5	5.0	4.0	3.3	2.7	2.2	1.8	----	----	----	----	----	----	
4"	66.0	48.3	37.0	23.7	16.3	12.0	9.2	7.2	5.7	4.7	3.8	3.2	2.7	2.3	2.0	1.7	----	----	----	
6 5/8"	----	----	----	84.5	58.7	43.0	32.8	26.0	21.1	17.3	14.5	12.3	10.7	9.2	8.0	7.2	6.3	5.7	5.0	
8 5/8"	----	----	----	----	----	85.2	65.2	51.5	41.7	34.3	28.8	24.7	21.2	18.5	16.2	14.3	12.7	11.3	10.3	
GROUP IC: (ASTM F1043) Steel Pipe (50,000 psi yield)																				
1 5/8"	5.3	3.8	2.8	1.7	1.1	----	----	----	----	----	----	----	----	----	----	----	----	----	----	
1 7/8"	7.6	5.6	4.2	2.6	1.7	1.1	----	----	----	----	----	----	----	----	----	----	----	----	----	
2 3/8"	13.4	9.8	7.4	4.7	3.2	2.2	1.6	1.2	----	----	----	----	----	----	----	----	----	----	----	
2 7/8"	24.2	17.7	13.5	8.6	5.9	4.3	3.2	2.4	1.9	1.5	1.2	----	----	----	----	----	----	----	----	
3 1/2"	37.0	27.1	20.7	13.2	9.1	6.6	5.0	3.9	3.1	2.5	2.0	1.7	1.4	1.1	----	----	----	----	----	
4"	49.2	36.1	27.6	17.6	12.2	8.9	6.8	5.3	4.2	3.4	2.8	2.4	2.0	1.7	1.4	1.2	1.0	----	----	
GROUP II: (ASTM F1043) High Strength Cold Rolled Formed C-Shape (50,000 psi yield)																				
1 7/8" x 1 5/8" x .105	5.7	4.2	3.1	2.0	1.3	----	----	----	----	----	----	----	----	----	----	----	----	----	----	
1 7/8" x 1 5/8" x .121	9.7	7.1	5.4	3.3	2.2	1.6	1.1	----	----	----	----	----	----	----	----	----	----	----	----	
2 1/4" x 1 5/8" x .121	11.2	8.2	6.2	3.9	2.6	1.8	1.3	----	----	----	----	----	----	----	----	----	----	----	----	
3 1/4" x 2 1/2" x .130	27.6	20.1	15.3	9.5	6.4	4.4	3.1	2.2	1.6	1.1	----	----	----	----	----	----	----	----	----	

See Table 12 for post dimensions and material properties.

TABLE 3
LINE POST SELECTION: WIND SPEED 120 MPH
EXPOSURE CATEGORY "B"

LINE POST SIZE IN	LINE POST MAXIMUM SPACING, S (FEET) FOR USE IN EQUATION: $S' = S \times Cf1 \times Cf2 \times Cf3$ FENCE HEIGHT (FEET)																			
	3	3.5	4	5	6	7	8	9	10	11	12	13	14	15	16	17	18	19	20	
	Group IA: (ASTM F1043) Schedule 40 Steel Pipe, ASTM F1083 Regular Grade (30,000 psi yield)																			
1 7/8"	4.5	3.3	2.5	1.5	1.0	----	----	----	----	----	----	----	----	----	----	----	----	----	----	
2 3/8"	7.8	5.7	4.4	2.8	1.9	1.3	----	----	----	----	----	----	----	----	----	----	----	----	----	
2 7/8"	14.9	10.9	8.3	5.3	3.6	2.6	2.0	1.5	1.2	-----	----	----	----	----	----	----	----	----	----	
3 1/2"	24.2	17.7	13.6	8.7	6.0	4.4	3.3	2.6	2.1	1.7	1.4	1.1	----	----	----	----	----	----	----	
4"	33.6	24.7	18.9	12.1	8.4	6.1	4.7	3.6	2.9	2.4	2.0	1.7	1.4	1.2	1.0	----	----	----	----	
6 5/8"	----	----	----	43.1	29.9	21.9	16.8	13.2	10.7	8.8	7.4	6.3	5.4	4.7	4.1	3.6	3.2	2.9	2.6	
8 5/8"	----	----	----	----	----	43.4	33.2	26.2	21.2	17.5	14.7	12.5	10.8	9.4	8.2	7.3	6.5	5.8	5.2	
GROUP IA: (ASTM F1043) Schedule 40 Steel Pipe, ASTM F1083 High Strength Grade (50,000 psi yield strength)																				
1 7/8"	7.5	5.5	4.2	2.5	1.7	----	----	----	----	----	----	----	----	----	----	----	----	----	----	
2 3/8"	13.0	9.5	7.3	4.7	3.2	2.2	----	----	----	----	----	----	----	----	----	----	----	----	----	
2 7/8"	24.8	18.2	13.8	8.8	6.0	4.3	3.3	2.5	2.0	-----	----	----	----	----	----	----	----	----	----	
3 1/2"	40.3	29.5	22.7	14.5	10.0	7.3	5.5	4.3	3.5	2.8	2.3	1.8	----	----	----	----	----	----	----	
4"	56.0	41.2	31.5	20.2	14.0	10.2	7.8	6.0	4.8	4.0	3.3	2.8	2.3	2.0	1.7	----	----	----	----	
6 5/8"	----	----	----	71.8	49.8	36.5	28.0	22.0	17.8	14.7	12.3	10.5	9.0	7.8	6.8	6.0	5.3	4.8	4.3	
8 5/8"	----	----	----	----	----	72.3	55.3	43.7	35.3	29.2	24.5	20.8	18.0	15.7	13.7	12.2	10.8	9.7	8.7	
GROUP IC: (ASTM F1043) Steel Pipe (50,000 psi yield)																				
1 5/8"	4.5	3.2	2.4	1.4	----	----	----	----	----	----	----	----	----	----	----	----	----	----	----	
1 7/8"	6.5	4.7	3.6	2.2	1.4	----	----	----	----	----	----	----	----	----	----	----	----	----	----	
2 3/8"	11.4	8.3	6.3	4.0	2.7	1.9	1.4	1.0	----	----	----	----	----	----	----	----	----	----	----	
2 7/8"	20.5	15.1	11.5	7.3	5.0	3.6	2.7	2.1	1.6	1.3	1.0	----	----	----	----	----	----	----	----	
3 1/2"	31.4	23.1	17.6	11.2	7.8	5.6	4.3	3.3	2.6	2.1	1.7	1.4	1.2	-----	----	----	----	----	----	
4"	41.8	30.7	23.5	15.0	10.4	7.6	5.7	4.5	3.6	2.9	2.4	2.0	1.7	1.4	1.2	1.0	-----	----	----	
GROUP II: (ASTM F1043) High Strength Cold Rolled Formed C-Shape (50,000 psi yield)																				
1 7/8" x 1 5/8" x .105	4.8	3.5	2.7	1.7	1.1	----	----	----	----	----	----	----	----	----	----	----	----	----	----	
1 7/8" x 1 5/8" x .121	8.2	6.0	4.6	2.8	1.9	1.3	----	----	----	----	----	----	----	----	----	----	----	----	----	
2 1/4" x 1 5/8" x .121	9.5	6.9	5.3	3.3	2.2	1.5	1.1	----	----	----	----	----	----	----	----	----	----	----	----	
3 1/4" x 2 1/2" x .130	23.4	17.1	13	8.1	5.4	3.8	2.7	1.9	1.3	----	----	----	----	----	----	----	----	----	----	

See Table 12 for post dimensions and material properties.

TABLE 4
LINE POST SELECTION: WIND SPEED 130 MPH
EXPOSURE CATEGORY "B"

LINE POST SIZE IN	LINE POST MAXIMUM SPACING, S (FEET) FOR USE IN EQUATION: $S^2 = S \times Cf1 \times Cf2 \times Cf3$ FENCE HEIGHT (FEET)																		
	3	3.5	4	5	6	7	8	9	10	11	12	13	14	15	16	17	18	19	20
	Group IA: (ASTM F1043) Schedule 40 Steel Pipe, ASTM F1083 Regular Grade (30,000 psi yield)																		
1 7/8"	3.8	2.8	2.1	1.3	---	---	---	---	---	---	---	---	---	---	---	---	---	---	---
2 3/8"	6.7	4.9	3.7	2.3	1.6	1.1	---	---	---	---	---	---	---	---	---	---	---	---	---
2 7/8"	12.6	9.3	7.1	4.5	3.1	2.2	1.7	1.3	1.0	---	---	---	---	---	---	---	---	---	---
3 1/2"	20.6	15.1	11.5	7.4	5.1	3.7	2.8	2.2	1.8	1.4	1.2	---	---	---	---	---	---	---	---
4"	28.6	21	16.1	10.3	7.1	5.2	4.0	3.1	2.5	2.0	1.7	1.4	1.2	1.0	---	---	---	---	---
6 5/8"	---	---	---	36.6	25.4	18.7	14.3	11.3	9.1	7.5	6.3	5.4	4.6	4.0	3.5	3.1	2.7	2.4	2.2
8 5/8"	---	---	---	---	---	36.9	28.3	22.3	18.1	14.9	12.5	10.7	9.2	8.0	7.0	6.2	5.5	4.9	4.4
GROUP IA: (ASTM F1043) Schedule 40 Steel Pipe, ASTM F1083 High Strength Grade (50,000 psi yield strength)																			
1 7/8"	6.3	4.7	3.5	2.2	---	---	---	---	---	---	---	---	---	---	---	---	---	---	---
2 3/8"	11.2	8.2	6.2	3.8	2.7	1.8	---	---	---	---	---	---	---	---	---	---	---	---	---
2 7/8"	21.0	15.5	11.8	7.5	5.2	3.7	2.8	2.2	1.7	---	---	---	---	---	---	---	---	---	---
3 1/2"	34.3	25.2	19.2	12.3	8.5	6.2	4.7	3.7	3.0	2.3	2.0	---	---	---	---	---	---	---	---
4"	47.7	35.0	26.8	17.2	11.8	8.7	6.7	5.2	4.2	3.3	2.8	2.3	2.0	1.7	---	---	---	---	---
6 5/8"	---	---	---	61.0	42.3	31.2	23.8	18.8	15.2	12.5	10.5	9.0	7.7	6.7	5.8	5.2	4.5	4.0	3.7
8 5/8"	---	---	---	---	---	61.5	47.2	37.2	30.2	24.8	20.8	17.8	15.3	13.3	11.7	10.3	9.2	8.2	7.3
GROUP IC: (ASTM F1043) Steel Pipe (50,000 psi yield)																			
1 5/8"	3.8	2.8	2.1	1.2	---	---	---	---	---	---	---	---	---	---	---	---	---	---	---
1 7/8"	5.5	4.0	3.0	1.9	1.2	---	---	---	---	---	---	---	---	---	---	---	---	---	---
2 3/8"	9.7	7.1	5.4	3.4	2.3	1.6	1.2	---	---	---	---	---	---	---	---	---	---	---	---
2 7/8"	17.5	12.8	9.8	6.2	4.3	3.1	2.3	1.8	1.4	1.1	---	---	---	---	---	---	---	---	---
3 1/2"	26.7	19.6	15.0	9.6	6.6	4.8	3.6	2.8	2.2	1.8	1.5	1.2	---	---	---	---	---	---	---
4"	35.5	26.1	19.9	12.7	8.8	6.4	4.9	3.8	3.1	2.5	2.0	1.7	1.4	1.2	1.0	---	---	---	---
GROUP II: (ASTM F1043) High Strength Cold Rolled Formed C-Shape (50,000 psi yield)																			
1 7/8" x 1 5/8" x .105	4.1	3.0	2.3	1.4	---	---	---	---	---	---	---	---	---	---	---	---	---	---	---
1 7/8" x 1 5/8" x .121	7.0	5.1	3.9	2.4	1.6	1.1	---	---	---	---	---	---	---	---	---	---	---	---	---
2 1/4" x 1 5/8" x .121	8.1	5.9	4.5	2.8	1.9	1.3	---	---	---	---	---	---	---	---	---	---	---	---	---
3 1/4" x 2 1/2" x .130	19.9	14.5	11.0	6.9	4.6	3.2	2.3	1.6	1.1	---	---	---	---	---	---	---	---	---	---

See Table 12 for post dimensions and material properties.

TABLE 5
LINE POST SELECTION: WIND SPEED 140 MPH
EXPOSURE CATEGORY "B"

LINE POST SIZE IN	LINE POST MAXIMUM SPACING, S (FEET) FOR USE IN EQUATION: S'=S X Cf1 x Cf2 x Cf3 FENCE HEIGHT (FEET)																		
	3	3.5	4	5	6	7	8	9	10	11	12	13	14	15	16	17	18	19	20
	Group IA: (ASTM F1043) Schedule 40 Steel Pipe, ASTM F1083 Regular Grade (30,000 psi yield)																		
1 7/8"	3.3	2.4	1.8	1.1	---	---	---	---	---	---	---	---	---	---	---	---	---	---	---
2 3/8"	5.7	4.1	3.2	2.0	1.4	---	---	---	---	---	---	---	---	---	---	---	---	---	---
2 7/8"	10.8	7.9	6.0	3.8	2.6	1.9	1.4	1.1	---	---	---	---	---	---	---	---	---	---	---
3 1/2"	17.5	12.8	9.8	6.3	4.3	3.2	2.4	1.9	1.5	1.2	---	---	---	---	---	---	---	---	---
4"	24.3	17.8	13.6	8.7	6.0	4.4	3.4	2.6	2.1	1.7	1.4	1.2	1.0	---	---	---	---	---	---
6 5/8"	---	---	---	31.1	21.6	15.9	12.1	9.6	7.7	6.4	5.4	4.5	3.9	3.4	3.0	2.6	2.3	2.1	1.9
8 5/8"	---	---	---	---	---	31.4	24.0	19.0	15.4	12.7	10.6	9.1	7.8	6.8	6.0	5.3	4.7	4.2	3.8
GROUP IA: (ASTM F1043) Schedule 40 Steel Pipe, ASTM F1083 High Strength Grade (50,000 psi yield strength)																			
1 7/8"	5.5	4.0	3.0	1.8	---	---	---	---	---	---	---	---	---	---	---	---	---	---	---
2 3/8"	9.5	6.8	5.3	3.3	2.3	---	---	---	---	---	---	---	---	---	---	---	---	---	---
2 7/8"	18.0	13.2	10	6.3	4.3	3.2	2.3	1.8	---	---	---	---	---	---	---	---	---	---	---
3 1/2"	29.2	21.3	16.3	10.5	7.2	5.3	4.0	3.2	2.5	2.0	---	---	---	---	---	---	---	---	---
4"	40.5	29.7	22.7	14.5	10.0	7.3	5.7	4.3	3.5	2.8	2.3	2.0	1.7	---	---	---	---	---	---
6 5/8"	---	---	---	51.8	36.0	26.5	20.2	16.0	12.8	10.7	9.0	7.5	6.5	5.7	5.0	4.3	3.8	3.5	3.2
8 5/8"	---	---	---	---	---	52.3	40.0	31.7	25.7	21.2	17.7	15.2	13.0	11.3	10.0	8.8	7.8	7.0	6.3
GROUP IC: (ASTM F1043) Steel Pipe (50,000 psi yield)																			
1 5/8"	3.2	2.3	1.7	1.0	---	---	---	---	---	---	---	---	---	---	---	---	---	---	---
1 7/8"	4.7	3.4	2.6	1.6	1.0	---	---	---	---	---	---	---	---	---	---	---	---	---	---
2 3/8"	8.2	6.0	4.6	2.9	1.9	1.4	---	---	---	---	---	---	---	---	---	---	---	---	---
2 7/8"	14.8	10.9	8.3	5.3	3.6	2.6	2.0	1.5	1.2	---	---	---	---	---	---	---	---	---	---
3 1/2"	22.7	16.7	12.7	8.1	5.6	4.1	3.1	2.4	1.9	1.5	1.2	1.0	---	---	---	---	---	---	---
4"	30.2	22.2	17.0	10.8	7.5	5.5	4.1	3.2	2.6	2.1	1.7	1.4	1.2	1.0	---	---	---	---	---
GROUP II: (ASTM F1043) High Strength Cold Rolled Formed C-Shape (50,000 psi yield)																			
1 7/8" x 1 5/8" x .105	3.5	2.6	1.9	1.2	---	---	---	---	---	---	---	---	---	---	---	---	---	---	---
1 7/8" x 1 5/8" x .121	5.9	4.3	3.3	2.1	1.4	---	---	---	---	---	---	---	---	---	---	---	---	---	---
2 1/4" x 1 5/8" x .121	6.9	5.0	3.8	2.4	1.6	1.1	---	---	---	---	---	---	---	---	---	---	---	---	---
3 1/4" x 2 1/2" x .130	16.9	12.4	9.4	5.9	3.9	2.7	1.9	1.4	---	---	---	---	---	---	---	---	---	---	---

See Table 12 for post dimensions and material properties.

TABLE 6
LINE POST SELECTION: WIND SPEED 150 MPH
EXPOSURE CATEGORY "B"

LINE POST SIZE IN	LINE POST MAXIMUM SPACING, S (FEET) FOR USE IN EQUATION: $S' = S \times Cf1 \times Cf2 \times Cf3$ FENCE HEIGHT (FEET)																			
	3	3.5	4	5	6	7	8	9	10	11	12	13	14	15	16	17	18	19	20	
	Group IA: (ASTM F1043) Schedule 40 Steel Pipe, ASTM F1083 Regular Grade (30,000 psi yield)																			
1 7/8"	2.8	2.0	1.5	----	----	----	----	----	----	----	----	----	----	----	----	----	----	----	----	
2 3/8"	4.8	3.5	2.7	1.7	1.1	----	----	----	----	----	----	----	----	----	----	----	----	----	----	
2 7/8"	9.1	6.7	5.1	3.3	2.2	1.6	1.2	----	----	----	----	----	----	----	----	----	----	----	----	
3 1/2"	14.8	10.9	8.3	5.3	3.7	2.7	2.0	1.6	1.3	1.0	----	----	----	----	----	----	----	----	----	
4"	20.6	15.2	11.6	7.4	5.1	3.8	2.9	2.2	1.8	1.5	1.2	1.0	----	----	----	----	----	----	----	
6 5/8"	----	----	----	26.4	18.4	13.5	10.3	8.1	6.6	5.4	4.6	3.9	3.3	2.9	2.5	2.2	2.0	1.8	1.6	
8 5/8"	----	----	----	----	----	26.7	20.4	16.1	13.0	10.8	9.0	7.7	6.6	5.8	5.1	4.5	4.0	3.6	3.2	
GROUP IA: (ASTM F1043) Schedule 40 Steel Pipe, ASTM F1083 High Strength Grade (50,000 psi yield strength)																				
1 7/8"	4.7	3.3	2.5	----	----	----	----	----	----	----	----	----	----	----	----	----	----	----	----	
2 3/8"	8.0	5.8	4.5	2.8	1.8	----	----	----	----	----	----	----	----	----	----	----	----	----	----	
2 7/8"	15.2	11.2	8.5	5.5	3.7	2.7	2.0	----	----	----	----	----	----	----	----	----	----	----	----	
3 1/2"	24.7	18.2	13.8	8.8	6.2	4.5	3.3	2.7	2.2	1.7	----	----	----	----	----	----	----	----	----	
4"	34.3	25.3	19.3	12.3	8.5	6.3	4.8	3.7	3.0	2.5	2.0	1.7	----	----	----	----	----	----	----	
6 5/8"	----	----	----	44.0	30.7	22.5	17.2	13.5	11.0	9.0	7.7	6.5	5.5	4.8	4.2	3.7	3.3	3.0	2.7	
8 5/8"	----	----	----	----	----	44.5	34.0	26.8	21.7	18.0	15.0	12.8	11.0	9.7	8.5	7.5	6.7	6.0	5.3	
GROUP IC: (ASTM F1043) Steel Pipe (50,000 psi yield)																				
1 5/8"	2.8	2.0	1.5	----	----	----	----	----	----	----	----	----	----	----	----	----	----	----	----	
1 7/8"	4.0	2.9	2.2	1.3	----	----	----	----	----	----	----	----	----	----	----	----	----	----	----	
2 3/8"	7.0	5.1	3.9	2.4	1.7	1.2	----	----	----	----	----	----	----	----	----	----	----	----	----	
2 7/8"	12.6	9.2	7.1	4.5	3.1	2.2	1.7	1.3	----	----	----	----	----	----	----	----	----	----	----	
3 1/2"	19.3	14.2	10.8	6.9	4.8	3.5	2.6	2.0	1.6	1.3	1.1	----	----	----	----	----	----	----	----	
4"	25.7	18.8	14.4	9.2	6.4	4.6	3.5	2.8	2.2	1.8	1.5	1.2	1.0	----	----	----	----	----	----	
GROUP II: (ASTM F1043) High Strength Cold Rolled Formed C-Shape (50,000 psi yield)																				
1 7/8" x 1 5/8" x .105	3.0	2.2	1.6	1.0	----	----	----	----	----	----	----	----	----	----	----	----	----	----	----	
1 7/8" x 1 5/8" x .121	5.1	3.7	2.8	1.7	1.2	----	----	----	----	----	----	----	----	----	----	----	----	----	----	
2 1/4" x 1 5/8" x .121	5.8	4.3	3.2	2.0	1.3	----	----	----	----	----	----	----	----	----	----	----	----	----	----	
3 1/4" x 2 1/2" x .130	14.4	10.5	8.0	5.0	3.3	2.3	1.6	1.2	----	----	----	----	----	----	----	----	----	----	----	

See Table 12 for post dimensions and material properties.

TABLE 7
LINE POST SELECTION: WIND SPEED 160 MPH
EXPOSURE CATEGORY "B"

LINE POST SIZE IN	LINE POST MAXIMUM SPACING, S (FEET) FOR USE IN EQUATION: $S' = S \times C_{f1} \times C_{f2} \times C_{f3}$ FENCE HEIGHT (FEET)																		
	3	3.5	4	5	6	7	8	9	10	11	12	13	14	15	16	17	18	19	20
	Group IA: (ASTM F1043) Schedule 40 Steel Pipe, ASTM F1083 Regular Grade (30,000 psi yield)																		
1 7/8"	2.4	1.7	1.3	---	---	---	---	---	---	---	---	---	---	---	---	---	---	---	---
2 3/8"	4.1	3.0	2.3	1.4	---	---	---	---	---	---	---	---	---	---	---	---	---	---	---
2 7/8"	7.8	5.7	4.4	2.8	1.9	1.4	1.0	---	---	---	---	---	---	---	---	---	---	---	---
3 1/2"	12.6	9.3	7.1	4.5	3.1	2.3	1.7	1.3	1.1	---	---	---	---	---	---	---	---	---	---
4"	17.6	12.9	9.9	6.3	4.4	3.2	2.4	1.9	1.5	1.2	1.0	---	---	---	---	---	---	---	---
6 5/8"	---	---	---	22.5	15.6	11.5	8.8	6.9	5.6	4.6	3.9	3.3	2.8	2.5	2.1	1.9	1.7	1.5	1.3
8 5/8"	---	---	---	---	---	22.7	17.3	13.7	11.1	9.2	7.7	6.5	5.6	4.9	4.3	3.8	3.4	3.0	2.7
GROUP IA: (ASTM F1043) Schedule 40 Steel Pipe, ASTM F1083 High Strength Grade (50,000 psi yield strength)																			
1 7/8"	4.0	2.8	2.2	---	---	---	---	---	---	---	---	---	---	---	---	---	---	---	---
2 3/8"	6.8	5.0	3.8	2.3	---	---	---	---	---	---	---	---	---	---	---	---	---	---	---
2 7/8"	13.0	9.5	7.3	4.7	3.2	2.3	1.7	---	---	---	---	---	---	---	---	---	---	---	---
3 1/2"	21.0	15.5	11.8	7.5	5.2	3.8	2.8	2.2	1.8	---	---	---	---	---	---	---	---	---	---
4"	29.3	21.5	16.5	10.5	7.3	5.3	4.0	3.2	2.5	2.0	1.7	---	---	---	---	---	---	---	---
6 5/8"	---	---	---	37.5	26.0	19.2	14.7	11.5	9.3	7.7	6.5	5.5	4.7	4.2	3.5	3.2	2.8	2.5	2.2
8 5/8"	---	---	---	---	---	37.8	28.8	22.8	18.5	15.3	12.8	10.8	9.3	8.2	7.2	6.3	5.7	5.0	4.5
GROUP IC: (ASTM F1043) Steel Pipe (50,000 psi yield)																			
1 5/8"	2.3	1.7	1.3	---	---	---	---	---	---	---	---	---	---	---	---	---	---	---	---
1 7/8"	3.4	2.5	1.9	1.1	---	---	---	---	---	---	---	---	---	---	---	---	---	---	---
2 3/8"	5.9	4.3	3.3	2.1	1.4	---	---	---	---	---	---	---	---	---	---	---	---	---	---
2 7/8"	10.7	7.9	6.0	3.8	2.6	1.9	1.4	1.1	---	---	---	---	---	---	---	---	---	---	---
3 1/2"	16.4	12.0	9.2	5.9	4.0	2.9	2.2	1.7	1.4	1.1	---	---	---	---	---	---	---	---	---
4"	21.8	16.0	12.2	7.8	5.4	3.9	3.0	2.3	1.9	1.5	1.3	1.0	---	---	---	---	---	---	---
GROUP II: (ASTM F1043) High Strength Cold Rolled Formed C-Shape (50,000 psi yield)																			
1 7/8" x 1 5/8" x .105	2.5	1.8	1.4	---	---	---	---	---	---	---	---	---	---	---	---	---	---	---	---
1 7/8" x 1 5/8" x .121	4.3	3.1	2.4	1.5	---	---	---	---	---	---	---	---	---	---	---	---	---	---	---
2 1/4" x 1 5/8" x .121	5.0	3.6	2.7	1.7	1.1	---	---	---	---	---	---	---	---	---	---	---	---	---	---
3 1/4" x 2 1/2" x .130	12.2	8.9	6.8	4.2	2.8	2.0	1.4	---	---	---	---	---	---	---	---	---	---	---	---

See Table 12 for post dimensions and material properties

TABLE 8
LINE POST SELECTION: WIND SPEED 170 MPH
EXPOSURE CATEGORY "B"

LINE POST SIZE IN	LINE POST MAXIMUM SPACING, S (FEET) FOR USE IN EQUATION: $S' = S \times Cf1 \times Cf2 \times Cf3$ FENCE HEIGHT (FEET)																			
	3	3.5	4	5	6	7	8	9	10	11	12	13	14	15	16	17	18	19	20	
	Group IA: (ASTM F1043) Schedule 40 Steel Pipe, ASTM F1083 Regular Grade (30,000 psi yield)																			
1 7/8"	2.0	1.5	1.1	---	---	---	---	---	---	---	---	---	---	---	---	---	---	---	---	
2 3/8"	3.5	2.5	1.9	1.2	---	---	---	---	---	---	---	---	---	---	---	---	---	---	---	
2 7/8"	6.6	4.8	3.7	2.4	1.6	1.2	---	---	---	---	---	---	---	---	---	---	---	---	---	
3 1/2"	10.7	7.9	6.0	3.8	2.7	1.9	1.5	1.1	---	---	---	---	---	---	---	---	---	---	---	
4"	14.9	11.0	8.4	5.4	3.7	2.7	2.1	1.6	1.3	1.1	---	---	---	---	---	---	---	---	---	
6 5/8"	---	---	---	19.7	13.3	9.7	7.4	5.9	4.8	3.9	3.3	2.8	2.4	2.1	1.8	1.6	1.4	1.3	1.1	
8 5/8"	---	---	---	---	---	19.3	14.7	11.6	9.4	7.8	6.5	5.6	4.8	4.2	3.7	3.2	2.9	2.6	2.3	
GROUP IA: (ASTM F1043) Schedule 40 Steel Pipe, ASTM F1083 High Strength Grade (50,000 psi yield strength)																				
1 7/8"	3.3	2.5	1.8	---	---	---	---	---	---	---	---	---	---	---	---	---	---	---	---	
2 3/8"	5.8	4.2	3.2	2.0	---	---	---	---	---	---	---	---	---	---	---	---	---	---	---	
2 7/8"	11.0	8.0	6.2	4.0	2.7	2.0	---	---	---	---	---	---	---	---	---	---	---	---	---	
3 1/2"	17.8	13.2	10.0	6.3	4.5	3.2	2.5	1.8	---	---	---	---	---	---	---	---	---	---	---	
4"	24.8	18.3	14.0	9.0	6.2	4.5	3.5	2.7	2.2	1.8	---	---	---	---	---	---	---	---	---	
6 5/8"	---	---	---	31.8	22.2	16.2	12.3	9.8	8.0	6.5	5.5	4.7	4.0	3.5	3.0	2.7	2.3	2.2	1.8	
8 5/8"	---	---	---	---	---	32.2	24.5	19.3	15.7	13.0	10.8	9.3	8.0	7.0	6.2	5.3	4.8	4.3	3.8	
GROUP IC: (ASTM F1043) Steel Pipe (50,000 psi yield)																				
1 5/8"	2.0	1.4	1.1	---	---	---	---	---	---	---	---	---	---	---	---	---	---	---	---	
1 7/8"	2.9	2.1	1.6	---	---	---	---	---	---	---	---	---	---	---	---	---	---	---	---	
2 3/8"	5.0	3.7	2.8	1.8	1.2	---	---	---	---	---	---	---	---	---	---	---	---	---	---	
2 7/8"	9.1	6.7	5.1	3.2	2.2	1.6	1.2	---	---	---	---	---	---	---	---	---	---	---	---	
3 1/2"	13.9	10.2	7.8	5.0	3.4	2.5	1.9	1.5	1.2	---	---	---	---	---	---	---	---	---	---	
4"	18.5	13.6	10.4	6.6	4.6	3.4	2.5	2.0	1.6	1.3	1.1	---	---	---	---	---	---	---	---	
GROUP II: (ASTM F1043) High Strength Cold Rolled Formed C-Shape (50,000 psi yield)																				
1 7/8" x 1 5/8" x .105	2.1	1.6	1.2	---	---	---	---	---	---	---	---	---	---	---	---	---	---	---	---	
1 7/8" x 1 5/8" x .121	3.7	2.7	2.0	1.3	---	---	---	---	---	---	---	---	---	---	---	---	---	---	---	
2 1/4" x 1 5/8" x .121	4.2	3.1	2.3	1.5	---	---	---	---	---	---	---	---	---	---	---	---	---	---	---	
3 1/4" x 2 1/2" x .130	10.4	7.6	5.8	3.6	2.4	1.7	1.2	---	---	---	---	---	---	---	---	---	---	---	---	

See Table 12 for post dimensions and material properties.

TABLE 9**Mesh and Fabric Size Coefficients (Cf₁)***

FABRIC WIRE SIZE (O.D.)		3/8"	1/2	5/8"	1"	1 1/4"	1 3/4"	2"	2 1/4"
metric equiv. (mm) =>		9.5	12.7	15.8	25.4	31.8	44.5	50.8	57.1
diam. (in) diam.(mm)									
<i>#5 (0.207)</i>	5.26				2.92	3.52	4.73	5.33	5.92
<i>#6 (0.192)</i>	4.88				3.30	3.75	5.06	5.71	6.37
<i>#8 (0.162)</i>	4.11				3.58	4.36	5.89	6.67	7.44
<i>#9 (0.148)</i>	3.76	1.77	2.20	2.60	3.87	4.73	6.40	7.26	8.09
<i>10 (0.135)</i>	3.43	1.88	2.36	2.80	4.19	5.13	6.96	7.90	8.82
<i>11 (0.120)</i>	3.0	2.06	2.60	3.10	4.65	5.71	7.77	8.83	9.86
<i>12 (0.113)</i>	2.87	2.16	2.72	3.25	4.91	6.04	8.22	9.35	10.44
* - (Cf₁) =1 for solid panel fence									

TABLE 10**WIND EXPOSURE CATEGORY COEFFICIENTS (Cf₂)**

EXPOSURE CATEGORY	Kz		WIND COEFFICIENT: (Kz EXP B) / (Kz)		
	Fence height	0-15 FT	15-20 FT	0-15 FT	15-20 FT
B		0.57	0.62	1.00	1.00
C		0.85	0.9	0.67	0.69
D		1.03	1.08	0.55	0.57

NOTES:

EXPOSURE B: Urban and suburban areas, wooded areas or other terrain with numerous closely spaced obstructions having the size of single-family dwellings or larger.

EXPOSURE C: Open terrain with scattered obstructions having heights generally less than 30 ft. This includes flat open country, grasslands, and all water surfaces in hurricane prone regions.

EXPOSURE D: Flat, unobstructed areas and water surfaces outside hurricane-prone regions. This category includes smooth mud flats, salt flats, and unbroken ice.

TABLE 11
Ice Exposure Coefficients (Cf₃)

Regional Conditions	Cf ₃
Regions likely to experience heavy ice storms	0.45
Regions subject to moderate icing effects	0.85
Regions not subject to the effects of icing	1.00

NOTES

1. Maximum spacing of posts may be limited by top rail design.
2. Recommended maximum spacing of posts not to exceed 10'-0".
3. For solid fence use exposure coefficient (Cf₃) = 1.0.
4. Ice exposure coefficient is an arbitrary value that may be assigned based on the judgment of the designer, considering the probability of an event occurring where maximum ice accumulation and peak wind velocity occurs at the same time in the locality the fence is installed.

TABLE 13**Design Wind Pressure, q (LB / SF)**

EXPOSURE CATEGORY	Height (ft)	Kz	Wind Velocity (MPH)							
			105	110	120	130	140	150	160	170
B	0 - 15	0.57	16.00	16.58	19.74	23.16	26.86	30.84	35.09	39.61
	15 - 20	0.62	16.44	18.04	21.47	25.19	29.22	33.54	38.16	43.08
C	0 - 15	0.85	22.53	24.73	29.43	34.54	40.06	45.99	52.32	59.07
	15 - 20	0.90	23.86	26.18	31.16	36.57	42.42	48.69	55.40	62.54
D	0 - 15	1.03	27.30	29.97	35.66	41.85	48.54	55.72	63.40	71.57
	15 - 20	1.08	28.63	31.42	37.39	43.89	50.90	58.43	66.48	75.05

NOTES:

$$q = (0.00256)(Kz)(Kzt)(Kd)G(Cf)(V^2)$$

Kz = EXPOSURE COEFFICIENT (GIVEN ABOVE)

Kzt = 1.0 (TOPOGRAPHIC FACTOR, PRESUMED = 1 FOR NO TOPOGRAPHIC EFFECTS)

Kd = 0.85 (DIRECTIONALITY FACTOR)

G = .85 (GUST FACTOR)

Cf = 1.3 (FORCE COEFFICIENT)

V = VELOCITY (GIVEN ABOVE)

REF: ASCE 7-10, "MINIMUM DESIGN LOADS FOR BUILDINGS AND OTHER STRUCTURES"

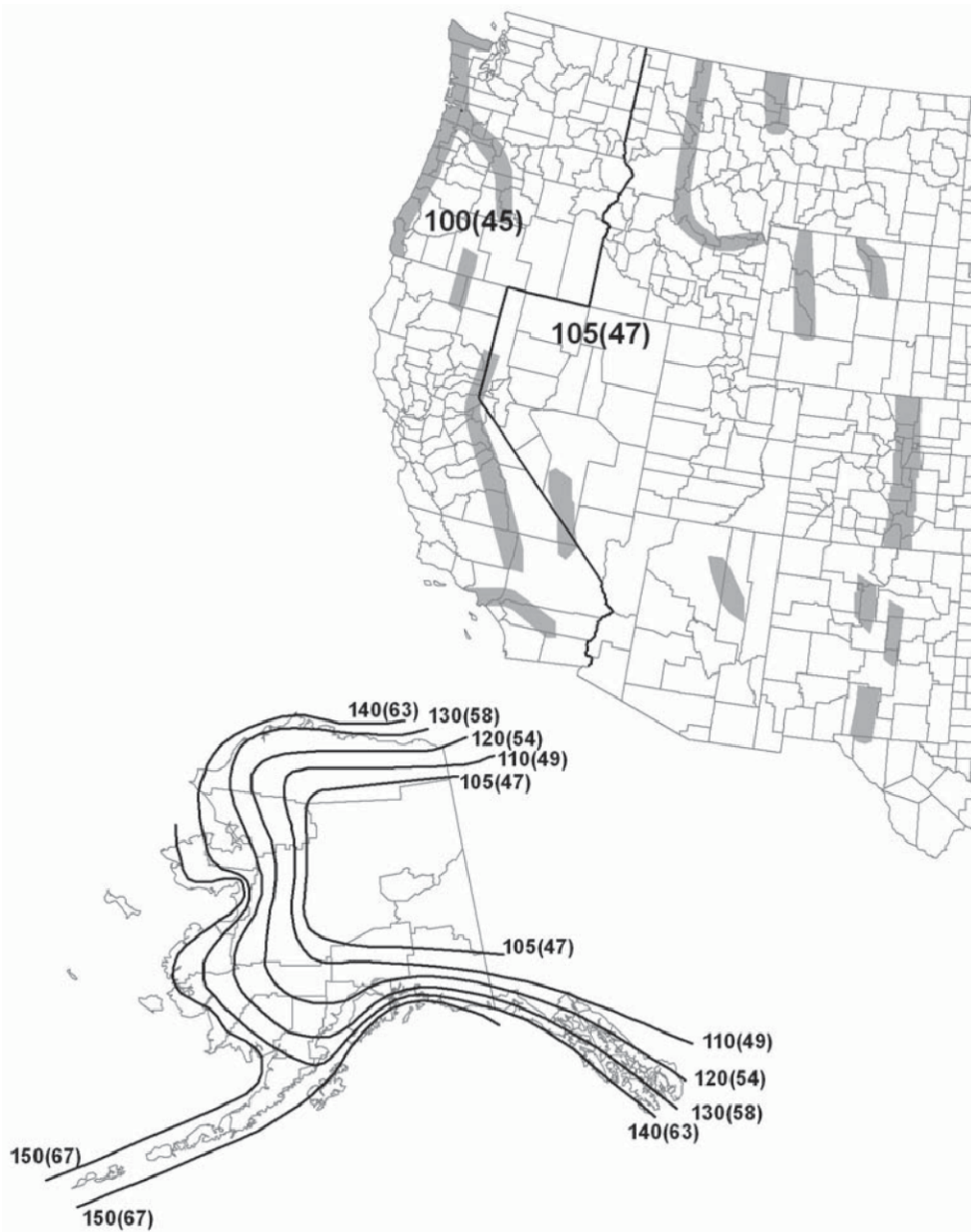

Figure 26.5-1C Basic Wind Speeds for Occupancy Category I Buildings and Other Structures.

Notes:

1. Values are nominal design 3-second gust wind speeds in miles per hour (m/s) at 33 ft (10m) above ground for Exposure C category.
2. Linear interpolation between contours is permitted.
3. Islands and coastal areas outside the last contour shall use the last wind speed contour of the coastal area.
4. Mountainous terrain, gorges, ocean promontories, and special wind regions shall be examined for unusual wind conditions.
5. Wind speeds correspond to approximately a 15% probability of exceedance in 50 years (Annual Exceedance Probability = 0.00333, MRI = 300 Years).

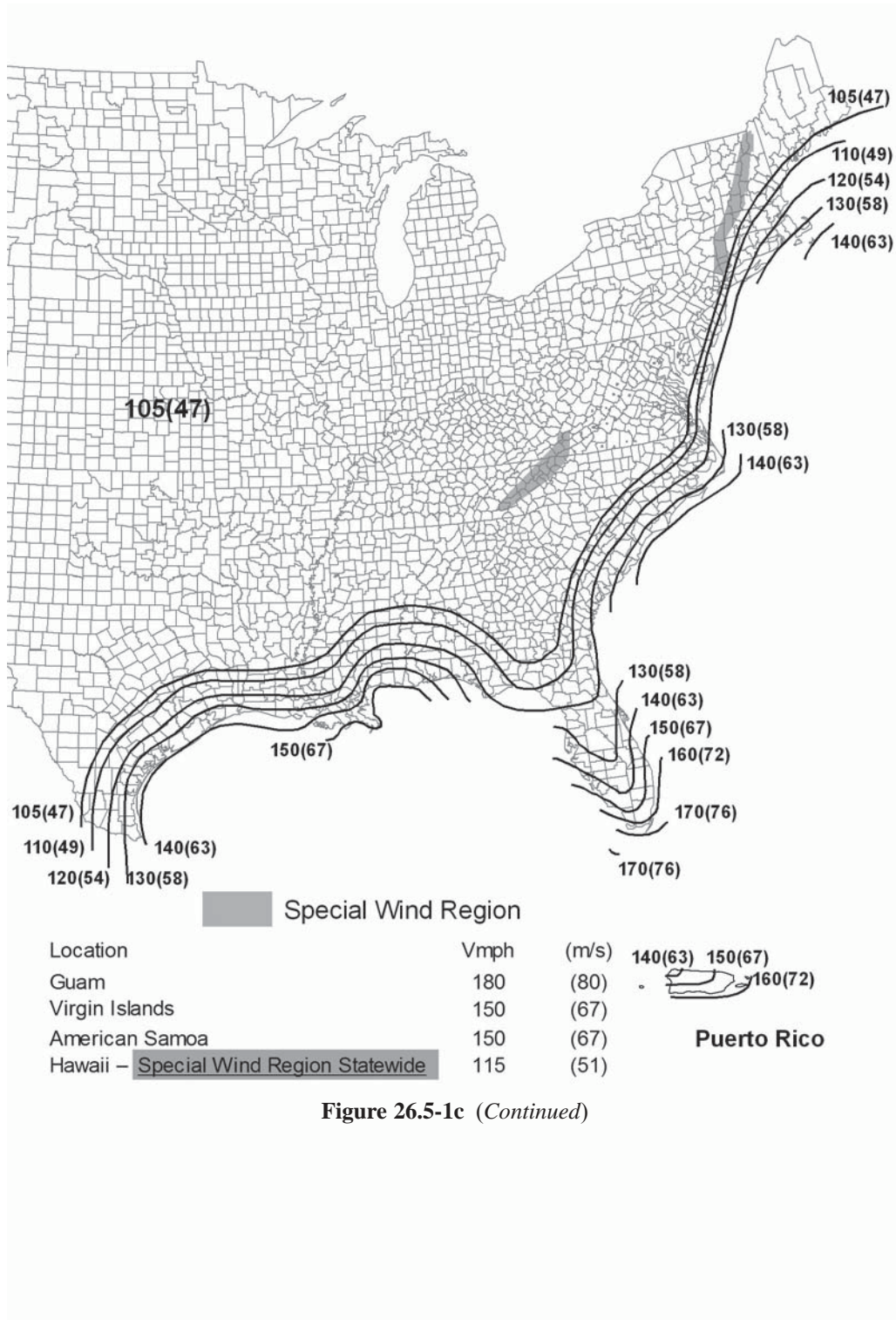

Figure 26.5-1c (Continued)

APPENDIX

METRIC CONVERSION FACTORS

LENGTH:

$$1 \text{ Ft} = 0.3048 \text{ m}$$

$$1 \text{ In} = 25.4 \text{ mm}$$

AREA:

$$1 \text{ sq ft} = 0.0929 \text{ sq m}$$

$$1 \text{ sq in} = 645.16 \text{ sq mm}$$

VELOCITY, SPEED:

$$1 \text{ Mph} = 1.6093 \text{ km/h}$$

MASS:

$$1 \text{ lb} = 0.4536 \text{ kg}$$

MASS PER UNIT AREA:

$$1 \text{ lb/sq ft} = 4.88224 \text{ kg/sq m}$$

FORCE:

$$1 \text{ kip (1,000 lbf)} = 4.44822 \text{ kN}$$

$$1 \text{ lbf (pound-force)} = 4.44822 \text{ N}$$

FORCE PER UNIT LENGTH:

$$1 \text{ lb/ft} = 14.5939 \text{ N/m}$$

$$1 \text{ lb/in} = 175.1268 \text{ N}$$

PRESSURE, STRESS, MODULUS OF ELASTICITY (FORCE/UNIT AREA):

$$1 \text{ lb/sq in} = 6.8947 \text{ kPa}$$

$$1 \text{ lb/sq ft} = 47.8803 \text{ Pa}$$

Terrain Exposure Constants

Table 26.9-1

Exposure	α	z (ft)	\hat{a}	\hat{b}	$\bar{\alpha}$	\bar{b}	c	z (ft)	\bar{z}	z_{min} (ft)*
B	7.0	1200	1/7	0.84	1/4.0	0.45	0.30	320	1/3.0	30
C	9.5	900	1/9.5	1.00	1/6.5	0.65	0.20	500	1/5.0	15
D	11.5	700	1/11.5	1.07	1/9.0	0.80	0.15	650	1/8.0	7

* z_{min} = minimum height used to ensure that the equivalent height \bar{z} is greater of $0.6h$ or z_{min} .
For buildings with $h \leq z_{min}$, \bar{z} shall be taken as z_{min} .

In metric

Exposure	α	z (m)	\hat{a}	\hat{b}	$\bar{\alpha}$	\bar{b}	c	z (m)	\bar{z}	z_{min} (m)*
B	7.0	365.76	1/7	0.84	1/4.0	0.45	0.30	97.54	1/3.0	9.14
C	9.5	274.32	1/9.5	1.00	1/6.5	0.65	0.20	152.4	1/5.0	4.57
D	11.5	213.36	1/11.5	1.07	1/9.0	0.80	0.15	198.12	1/8.0	2.13

* z_{min} = minimum height used to ensure that the equivalent height \bar{z} is greater of $0.6h$ or z_{min} .
For buildings with $h \leq z_{min}$, \bar{z} shall be taken as z_{min} .

26.7.3 Exposure Categories

Exposure B: For buildings with a mean roof height of less than or equal to 30 ft (9.1 m), Exposure B shall apply where the ground surface roughness, as defined by Surface Roughness B, prevails in the upwind direction for a distance greater than 1,500 ft (457 m). For buildings with a mean roof height greater than 30 ft (9.1 m), Exposure B shall apply where Surface Roughness B prevails in the upwind direction for a distance greater than 2,600 ft (792 m) or 20 times the height of the building, whichever is greater.

Exposure C: Exposure C shall apply for all cases where Exposures B or D do not apply.

Exposure D: Exposure D shall apply where the ground surface roughness, as defined by Surface Roughness D, prevails in the upwind direction for a distance greater than 5,000 ft (1,524 m) or 20 times the building height, whichever is greater. Exposure D shall also apply where the ground surface roughness immediately upwind of the site is B or C, and the site is within a distance of 600 ft (183 m) or 20 times the building height, whichever is greater, from an Exposure D condition as defined in the previous sentence. For a site located in the transition zone between exposure categories, the category resulting in the largest wind forces shall be used.

EXCEPTION: An intermediate exposure between the preceding categories is permitted in a transition zone provided that it is determined by a rational analysis method defined in the recognized literature.

29.3.2 Velocity Pressure

Velocity pressure, q_z , evaluated at height z shall be calculated by the following equation:

$$q_z = 0.00256 K_z K_{zt} K_d V^2 \text{ (lb/ft}^2\text{)} \text{ (29.3-1)}$$

$$\text{[In SI: } q_z = 0.613 K_z K_{zt} K_d V^2 \text{ (N/m}^2\text{); } V \text{ in m/s]}$$

where:

K_d = wind directionality factor defined in Section 26.6

K_z = velocity pressure exposure coefficient defined in Section 29.3.1

K_{zt} = topographic factor defined in Section 26.8.2

V = basic wind speed from Section 26.5.

q_h = velocity pressure calculated using Eq. 29.3-1 at height h

The numerical coefficient 0.00256 (0.613 in SI) shall be used except where sufficient climatic data are available to justify the selection of a different value of this factor for a design application.

Wind Directionality Factor, K_d	
Table 26.6-1	
Structure Type	Directionality Factor K_d*
Buildings	
Main Wind Force Resisting System	0.85
Components and Cladding	0.85
Arched Roofs	0.85
Chimneys, Tanks, and Similar Structures	
Square	0.90
Hexagonal	0.95
Round	0.95
Solid Freestanding Walls and Solid Freestanding and Attached Signs	0.85
Open Signs and Lattice Framework	0.85
Trussed Towers	
Triangular, square, rectangular	0.85
All other cross sections	0.95
<p>*Directionality Factor K_d has been calibrated with combinations of loads specified in Chapter 2. This factor shall only be applied when used in conjunction with load combinations specified in Sections 2.3 and 2.4.</p>	

Velocity Pressure Exposure Coefficients, K_h and K_z				
Table 29.3-1				
Height above ground level, z		Exposure		
ft	(m)	B	C	D
0-15	(0-4.6)	0.57	0.85	1.03
20	(6.1)	0.62	0.90	1.08
25	(7.6)	0.66	0.94	1.12
30	(9.1)	0.70	0.98	1.16
40	(12.2)	0.76	1.04	1.22
50	(15.2)	0.81	1.09	1.27
60	(18)	0.85	1.13	1.31
70	(21.3)	0.89	1.17	1.34
80	(24.4)	0.93	1.21	1.38
90	(27.4)	0.96	1.24	1.40
100	(30.5)	0.99	1.26	1.43
120	(36.6)	1.04	1.31	1.48
140	(42.7)	1.09	1.36	1.52
160	(48.8)	1.13	1.39	1.55
180	(54.9)	1.17	1.43	1.58
200	(61.0)	1.20	1.46	1.61
250	(76.2)	1.28	1.53	1.68
300	(91.4)	1.35	1.59	1.73
350	(106.7)	1.41	1.64	1.78
400	(121.9)	1.47	1.69	1.82
450	(137.2)	1.52	1.73	1.86
500	(152.4)	1.56	1.77	1.89

Notes:

1. The velocity pressure exposure coefficient K_z may be determined from the following formula:

For $15 \text{ ft.} \leq z \leq z_g$	For $z < 15 \text{ ft.}$
$K_z = 2.01 (z/z_g)^{2/\alpha}$	$K_z = 2.01 (15/z_g)^{2/\alpha}$
2. α and z_g are tabulated in Table 26.9.1.
3. Linear interpolation for intermediate values of height z is acceptable.
4. Exposure categories are defined in Section 26.7.

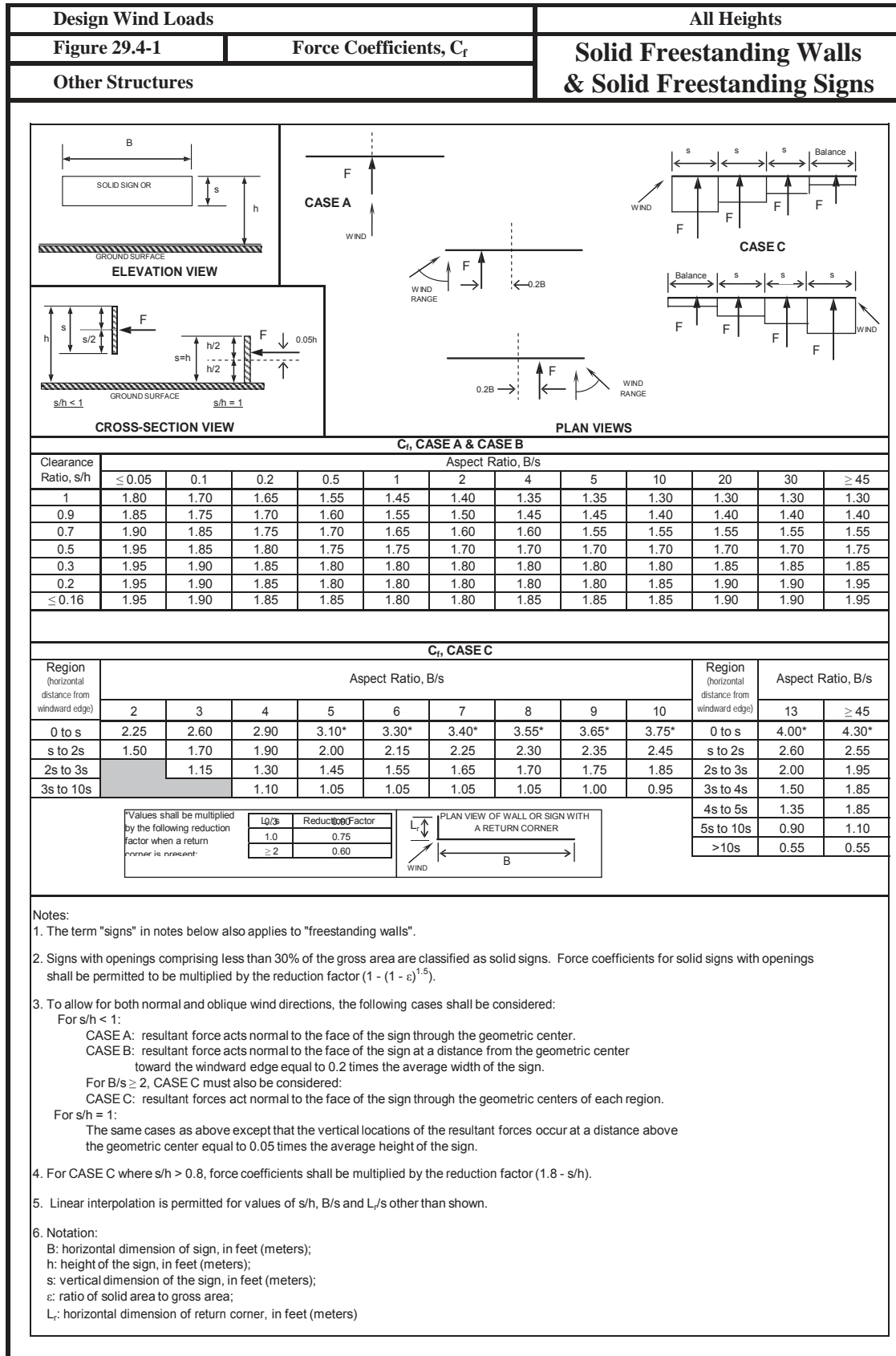

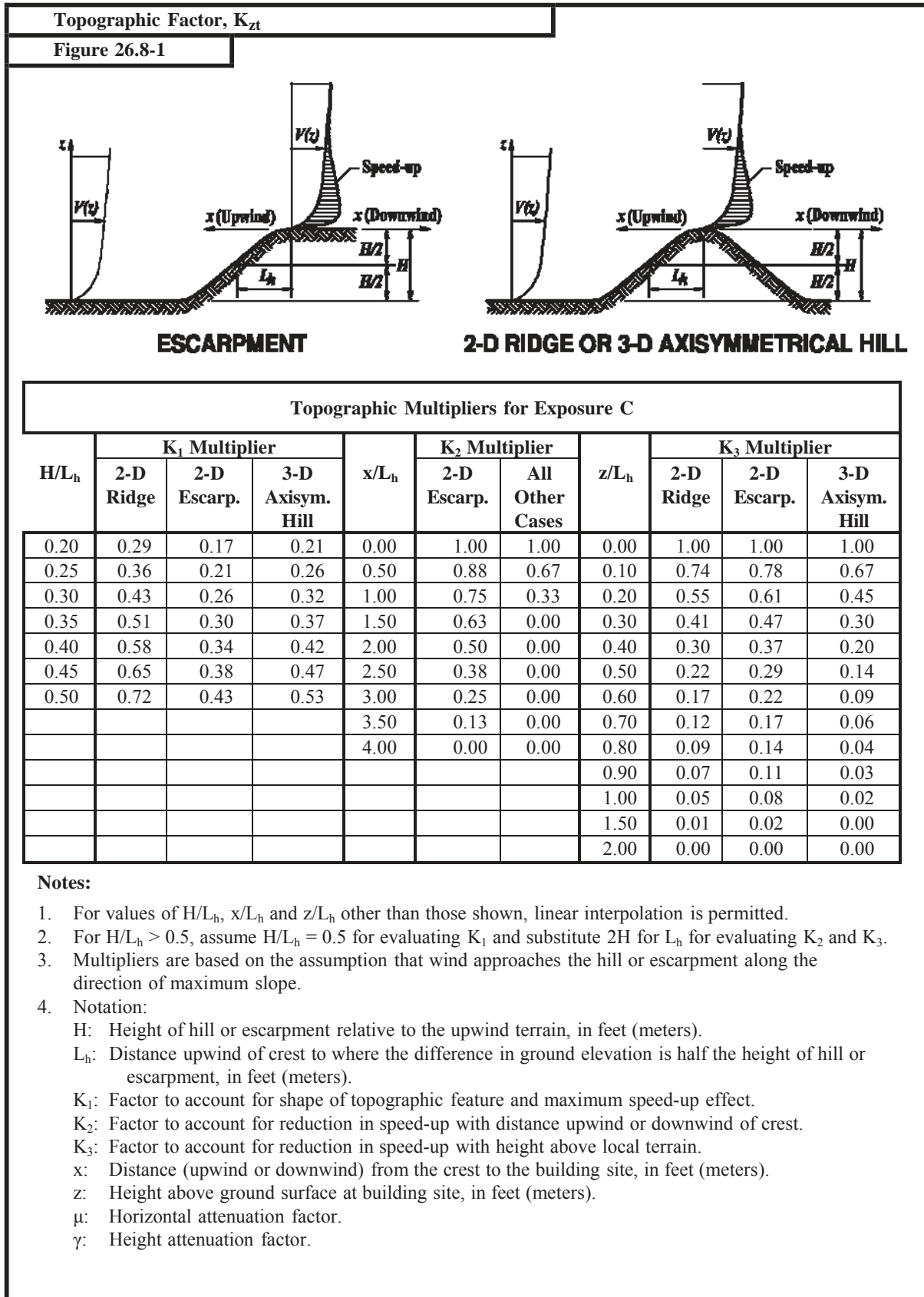

loads, the calculations shall be in accordance with Sections 1806.3.1 through 1806.3.4.

1806.3.1 Combined resistance. The total resistance to lateral loads shall be permitted to be determined by combining the values derived from the lateral bearing pressure and the lateral sliding resistance specified in Table 1806.2.

1806.3.2 Lateral sliding resistance limit. For clay, sandy clay, silty clay, clayey silt, silt and sandy silt, in no case shall the lateral sliding resistance exceed one-half the dead load.

1806.3.3 Increase for depth. The lateral bearing pressures specified in Table 1806.2 shall be permitted to be increased by the tabular value for each additional foot (305 mm) of depth to a maximum of 15 times the tabular value.

1806.3.4 Increase for poles. Isolated poles for uses such as flagpoles or signs and poles used to support buildings that are not adversely affected by a 1/2 inch (12.7 mm) motion at the ground surface due to short-term lateral loads shall be permitted to be designed using lateral bearing pressures equal to two times the tabular values.

**SECTION 1807
FOUNDATION WALLS, RETAINING WALLS AND
EMBEDDED POSTS AND POLES**

1807.1 Foundation walls. Foundation walls shall be designed and constructed in accordance with Sections 1807.1.1 through 1807.1.6. Foundation walls shall be supported by foundations designed in accordance with Section 1808.

1807.1.1 Design lateral soil loads. Foundation walls shall be designed for the lateral soil loads set forth in Section 1610.

1807.1.2 Unbalanced backfill height. Unbalanced backfill height is the difference in height between the exterior finish ground level and the lower of the top of the concrete footing that supports the foundation wall or the interior finish ground level. Where an interior concrete slab on grade is provided and is in contact with the interior surface of the foundation wall, the unbalanced backfill height shall be permitted to be measured from the exterior finish ground level to the top of the interior concrete slab.

1807.1.3 Rubble stone foundation walls. Foundation walls of rough or random rubble stone shall not be less than 16 inches (406 mm) thick. Rubble stone shall not be used for foundation walls of structures assigned to *Seismic Design Category* C, D, E or F.

1807.1.4 Permanent wood foundation systems. Permanent wood foundation systems shall be designed and installed in accordance with AF & PA PWF. Lumber and plywood shall be treated in accordance with AWPA UI (Commodity Specification A, Use Category 4B and Section 5.2) and shall be identified in accordance with Section 2303.1.8.1.

1807.1.5 Concrete and masonry foundation walls. Concrete and masonry foundation walls shall be designed in accordance with Chapter 19 or 21, as applicable.

Exception: Concrete and masonry foundation walls shall be permitted to be designed and constructed in accordance with Section 1807.1.6.

TABLE 1806.2
PRESUMPTIVE LOAD-BEARING VALUES

CLASS OF MATERIALS	VERTICAL FOUNDATION PRESSURE (psf)	LATERAL BEARING PRESSURE (psf/f below natural grade)	LATERAL SLIDING RESISTANCE	
			Coefficient of friction ^a	Cohesion (psf) ^b
1. Crystalline bedrock	12,000	1,200	0.70	-
2. Sedimentary and foliated rock	4,000	400	0.35	-
3. Sandy gravel and/or gravel (GW and GP)	3,000	200	0.35	-
4. Sand, silty sand, clayey sand, silty gravel and clayey gravel (SW, SP, SM, SC, GM and GC)	2,000	150	0.25	-
5. Clay, sandy clay, silty clay, clayey silt, silt and sandy silt (CL, ML, MH and CH)	1,500	100	-	130

For SI: 1 pound per square foot = 0.0479 kPa, 1 pound per square foot per foot = 0.157 kPa/m.

a. Coefficient to be multiplied by the dead load.

b. Cohesion value to be multiplied by the contact area, as limited by Section 1806.3.2.

REFERENCES

ASCE Publication ASCE 7-10, "Minimum Load Design Criteria for Buildings and Other Structures," Section 26, Wind Loads.

American Society of Testing Materials Standard, ASTM F1043, Standard Specification for Strength and Protective Coatings on Metal Industrial Chain Link Fence Framework

American Society of Testing Materials Standard, ASTM F567, Standard Practice for Installation of Chain Link Fence.

American Society of Testing Materials Standard, ASTM F1083, Pipe, Steel, Hot-Dipped Zinc Coated (Galvanized) Welded for Fence Structures

American Institute of Steel Construction, "Manual of Steel Construction-Allowable Stress Design"

*Copyrighted material reproduced by permission of the author and publisher, The American Society of Civil Engineers, from ASCE 7-10.