



Zoeller 841-0017, Model EX841, X840 Series, Explosion Proof High Flow Single Directional Grinder Pump, 2 HP, 230 Volts, 1 Phase, 1-1/4" NPT Vertical Discharge, 59 GPM Max, 125 ft Max Head, 20 ft Cord, Manual



SKU #: 841-0017 Brand: Zoeller

✔ Available For Order! ((Usually Ships 3-5 Days))

✔ Free Shipping

Price:

\$4,807.64

✔ Call Sales Counter!

Calculate Shipping

Ship

Weight (155.00 lbs)

QUESTIONS?



Ask Inspector Pumphead
1-800-429-0800

DESCRIPTION

FEATURES

Zoeller EX841 Explosion Proof Single Directional Grinder Pump

"The Shark" series of submersible grinder pumps is designed for use in residential or commercial wastewater applications in Class I, Division 1, Groups C and D environments. Each pump is FM/CSA approved and features innovative motor and electrical enclosures that are designed to reduce the risk of vapor ignition both inside and outside the pump. Should vapors inside the electrical enclosure become ignited, the enclosure is engineered to contain the event and prevent escalation. Each pump is constructed of hardware that will allow it to operate safely and efficiently in extreme conditions.

WARNING: Not for use in acidic, methanol, or ethyl acetate atmospheres

Features

- cFMus and CSA rated Class I, Division 1, Group C & D
- Cast iron construction
- Corrosion-resistant, powder coated epoxy finish
- Stainless steel cutter, plate and shaft
- Stainless steel screws, bolts and lifting bail
- 3450 RPM motor with automatic thermal overload protection
- Oil-filled, hermetically sealed motor with Class F insulation
- Hardened stainless steel cutter and disc Rockwell C55-60
- Reversible cutter action
- Non-clogging bronze vortex impeller
- Upper and lower ball bearing construction
- Dual mechanical seals with leak detection
- Carbon/ceramic tandem seals
- Legs provide for free standing installation
- 20 ft UL listed SOOW power cord- 20 ft sensor cord
- Threaded conduit connection on pump cap to provide protection to power cord and sensor wires
- This model is also available with 35 and 50 ft cord lengths
- Thermal sensors- (overload) and moisture probes require circuit in control panel to function reversible feature

QUESTIONS?



**Ask Inspector Pumphead
1-800-429-0800**

COMPATIBILITY

MANUALS



FM2615 Owner's Manual, X800 Series 60 Hz.pdf



FM2855 Technical Data, X840 X841 X842 60 Hz.pdf

SPECIFICATIONS

Brand	Zoeller
Mfg. Number	841-0017
Series	X840
Model	EX841
Product Type	Explosion proof high flow single directional grinder pump
Application	Residential/Commercial wastewater
Operation	Manual
Horsepower	2 HP
Voltage	230 Volts
Phase	1
Frequency	60 Hz
Speed	3450 RPM
Pump Casing	Cast iron
Maximum Flow	62 GPM
Maximum Total Head	124 ft
Discharge Connection	1-1/4" NPT-vertical

QUESTIONS?



Ask Inspector Pumphead
1-800-429-0800

Maximum Current	17.2 Amps
Impeller Design	Non-clogging, vortex
Power Cord Length	20 ft
Impeller Material	Bronze
Maximum Temperature (Continuos)	104°F
Motor Insulation	Class F
Overload Protection	Yes

REPAIR PARTS

REPAIR DIAGRAM



[Zoeller_Grinder_Pumps_Shark_841_Series_Repair_Parts_9.pdf](#)

BUYERS GUIDES

QUESTIONS?



**Ask Inspector Pumphead
1-800-429-0800**

This series of submersible grinder pumps is designed for use in residential or commercial wastewater applications in Class I, Division 1, Groups C and D environments. Each pump is FM/CSA approved and features innovative motor and electrical enclosures that are designed to reduce the risk of vapor ignition both inside and outside the pump. Should vapors inside the electrical enclosures become ignited, the enclosures are engineered to contain the event and prevent escalation. Each pump is constructed of hardware that will allow it to operate safely and efficiently in extreme conditions. As with every Zoeller pump, each one is 100% factory tested to ensure quality and reliability for years of trouble free performance! This attention to detail is an inherent feature of every pump in this series, making it one of the most reliable in the industry.

Features

Surface temperature code T5 (1 Ph) or T6 (3 Ph).

Includes a stainless steel lifting bracket for easy installation and removal.

All models are hermetically sealed to be watertight, dust-tight, and completely submersible.

ZOELLER X840 SERIES GRINDER PUMPS



QUESTIONS?



Ask Inspector Pumphead
1-800-429-0800

Model Comparison Chart

Model	Discharge (NPT Vertical)	HP	Voltage	Phase	GPM	Max. Head
<u>FX840</u>	1-1/4"	2	230	3	45	104'
<u>GX840</u>	1-1/4"	2	460	3	45	104'
<u>JX840</u>	1-1/4"	2	200-208	3	45	104'
<u>EX840</u>	1-1/4"	2	230	1	45	104'
<u>IX840</u>	1-1/4"	2	200-208	1	45	104'
<u>FX841</u>	1-1/4"	2	230	3	59	125'
<u>FX842</u>	1-1/4"	2	230	3	34	125'
<u>GX841</u>	1-1/4"	2	460	3	59	125'
<u>GX842</u>	1-1/4"	2	460	3	34	125'
<u>JX841</u>	1-1/4"	2	200-208	3	59	125'
<u>JX842</u>	1-1/4"	2	200-208	3	34	125'
<u>EX841</u>	1-1/4"	2	230	1	59	125'
<u>EX842</u>	1-1/4"	2	230	1	34	125'
<u>IX841</u>	1-1/4"	2	200-208	1		
<u>IX842</u>	1-1/4"	2	200-208	1	34	125'

QUESTIONS?



**Ask Inspector Pumphead
1-800-429-0800**

PERFORMANCE CURVES

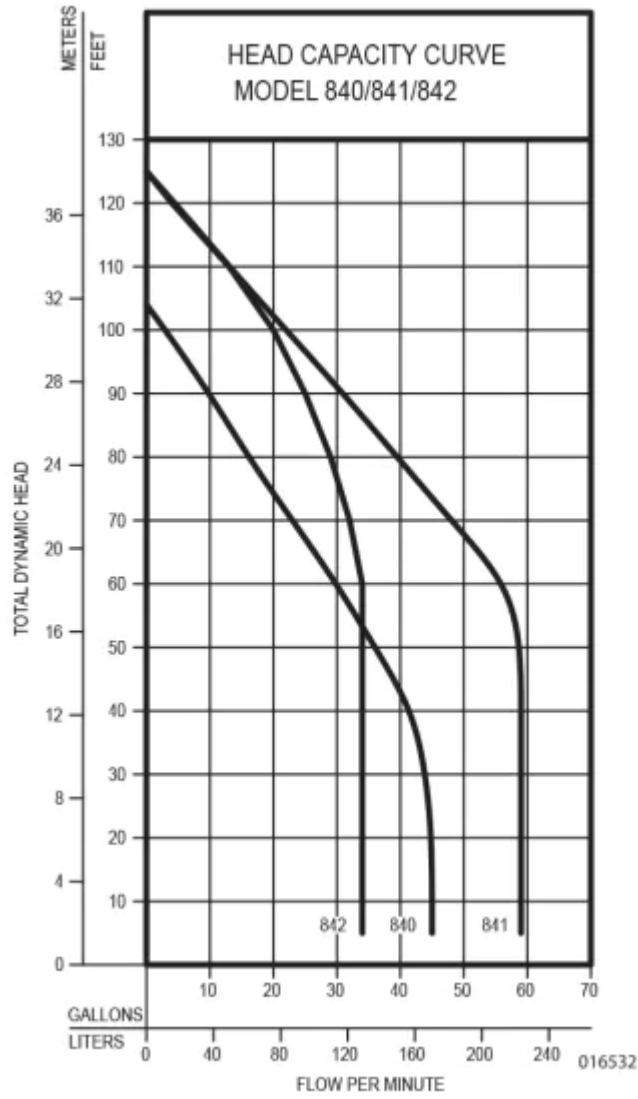

DIMENSIONS

QUESTIONS?



Ask Inspector Pumphead
1-800-429-0800

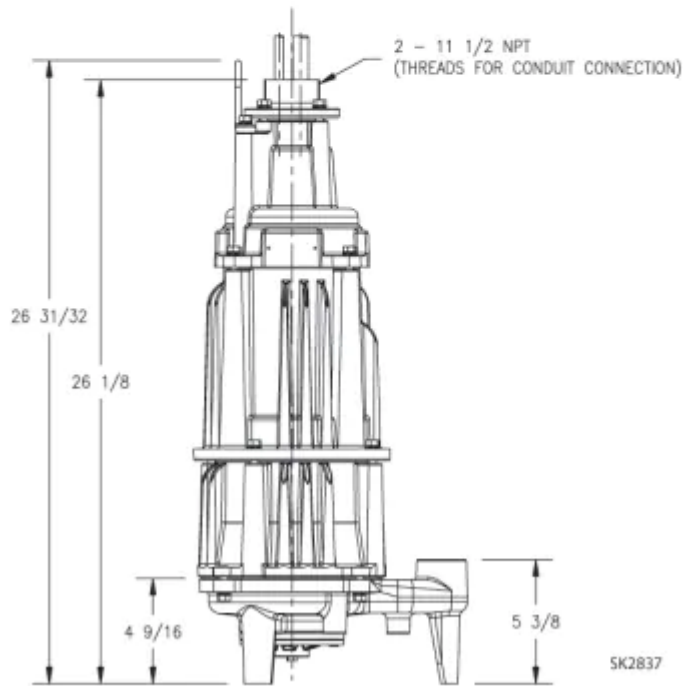
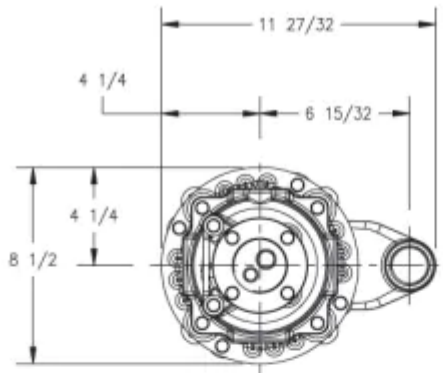

SERVICE CHECKLIST

QUESTIONS?



**Ask Inspector Pumphead
1-800-429-0800**

Service Checklist



⚠ WARNING Electrical precautions. Before servicing a grinder pump, always shut off the main power circuit. Make sure you are wearing insulated protective sole shoes and not standing in water. Under flooded conditions, contact your local electric company or a qualified licensed electrician for disconnecting electrical service to the pump prior to removal.



⚠ WARNING Grinder pumps contain oil which becomes pressurized and hot under operating conditions. Allow 2½ hours after shut down before servicing pump.

Condition	Common Causes
A. Pump will not start or run.	Blown panel or circuit breaker fuse, low voltage, thermal overload open, defective capacitor circuit, cutter or impeller clogged, float switch held down or defective, incorrect wiring in control panel, water in cap assembly.
B. Motor overheats and trips on overload.	Incorrect voltage, impeller or cutter blocked, negative head (discharge lower than intake of pump). Defective "off" float. Pump runs continuously at low water level. Low oil level in motor shell.
C. Pump will not shut off.	Air lock, debris under float assembly, defective switch, incoming sewage exceeds capacity of pump.
D. Pump operates but delivers little or no water.	Intake clogged with grease or sludge, pump air locked (clear vent hole), low or incorrect voltage, clogged discharge line, operating near shut-off head.
E. Pump starts and stops too often.	Check valve stuck open or defective. Sump pit too small to handle incoming sewage. Level control out of adjustment. Thermal overload tripping.
F. Large red flashing light comes on at control box.	High water in pit. Check pump for clogging, or overload trip. On single phase pumps, check the start capacitor in the control panel. See "A" and "D" above.
G. Grease and solids accumulate in pit around pump.	Break up solids and run pump with water running into the pit. Allow level to lower to the pump intake. Continue until solids are cleared from the pit. Do not drain kitchen grease down the sink.

SPECIFICATIONS

QUESTIONS?



**Ask Inspector Pumpehead
1-800-429-0800**

MOTOR	Horse Power	2
	Voltage	200 - 575
	Phase	1 or 3 Ph
	Hertz	60 Hz
	RPM	3450
	Type	Capacitor start / capacitor run or 3 Ph
	Insulation	Class F
	Amps	4.5 - 20.0
PUMP	Operation	Nonautomatic
	Discharge Size	1¼" NPT vertical
	Cord Length	20' (6 m) standard
	Cord Type	UL listed, SOOW
	Max. Head	125' (38.1 m)
	Max. Flow Rate	59 GPM (223 LPM)
	Max. Operating Temp.	104° F (40° C)
	Cooling	Oil filled
	Motor Protection	Auto reset thermal overload (1 Ph) or thermal sensor (3 Ph)
MATERIALS	Cap	Cast iron
	Motor Housing	Cast iron
	Adapter	Cast iron
	Pump Housing	Cast iron
	Upper Bearing	Ball bearing
	Lower Bearing	Ball bearing
	Mechanical Seals	Carbon/ceramic with stainless steel parts
	Impeller Type	Non-clogging vortex
	Impeller	Ductile iron or bronze
	Hardware	Stainless steel
	Motor Shaft	Stainless steel
	Square Rings	Neoprene
	Cutter	Hardened stainless steel, Rockwell C55-60

QUESTIONS?

TDH FLOW PER MINUTE



Ask Inspector Pumphead
1-800-429-0800

MODEL		X840		X841		X842	
Feet	Meters	Gal.	Liters	Gal.	Liters	Gal.	Liters
5	1.5	45	170	59	223	34	129
10	3.0	45	170	59	223	34	129
20	6.1	45	170	59	223	34	129
30	9.1	44	167	59	223	34	129
40	12.2	42	159	59	223	34	129
50	15.2	36	136	59	223	34	129
60	18.3	30	114	57	216	34	129
70	21.3	23	87	48	182	32	121
80	24.4	16	61	39.5	150	29	110
90	27.4	10	38	31	117	25	95
100	30.5	3	11	22	83	20	76
110	33.5	--	--	13	49	13	49
120	36.6	--	--	4.5	17	4	15
Shut-off Head:		104 ft (31.7 m)		125 ft (38.1 m)		125 ft (38.1 m)	

BROCHURE

Zoeller X840 Series Grinder Pumps Brochure

OWNER'S MANUAL

Zoeller X840 Series Grinder Pumps Owners Manual

TECHNICAL DATA

Zoeller X840 Series Grinder Pumps Technical Data

QUESTIONS?

Pump Products application engineers are standing by to help you find the right pump, as well as to provide price quotes, stocking availability and shipping information. Call our toll free number 1-800-429-0800 to speak to an expert today.



**Ask Inspector Pumphead
1-800-429-0800**

Call Our Sales Counter For Assistance, Price Quotes, Availability & To Place An Order

Inspector Pumphead & Our Customer Service Representatives Are Available

Mon-Fri 7:30 am to 5:00 pm EST

 Call Toll Free: **800-429-0800**



"Ask Inspector PumpHead"

* **Note:** Picture is illustrative and may not reflect the actual product. *

CONNECT WITH US

 [Find Us on Facebook](#)

 [Follow us on Twitter](#)

 [Watch us on YouTube](#)

 [Read our Blog](#)

 [View us on Instagram](#)

 [Network with us on LinkedIn](#)

SECURE SHOPPING



OUR MEMBERSHIPS



Ask Inspector Pumphead
1-800-429-0800



SERVICE EXCELLENCE



Product Experts
Available

**CALL US: 1-800-
429-0800**

COMPANY INFORMATION

[Company Profile](#)
[Meet The Team](#)
[Our Latest News](#)
[Company Information](#)

CUSTOMER SERVICE

[Contact Us](#)
[Website Suggestions](#)
[Privacy Policy](#)
[Terms of Use](#)
[Help FAQs](#)

BUYERS GUIDES

[Sump Pump](#)
[Well Pump](#)
[Pond Pump](#)
[Transfer Pump](#)
[View All Guides](#)

QUESTIONS?



**Ask Inspector Pumphead
1-800-429-0800**

PRODUCT SUPPORT

[Repair Parts Help](#)

[Quick Tips](#)

[Product Reviews](#)

[Technical Support](#)

[Brands](#)

ORDER SUPPORT

[Placing an Order](#)

[Track Your Order](#)

[Shipping & Delivery](#)

[Returns Policy](#)

[Update Your Account](#)

© Pump Products 2019 | [Tel.: 1-800-429-0800](tel:1-800-429-0800) | Fax. 201-497-6596 | info@pumpproducts.com

QUESTIONS?



**Ask Inspector Pumphead
1-800-429-0800**