

SHOP DRAWING and SAMPLE TRANSMITTAL

DATE: September 25, 2025

TO: James G. Cochran
 Cochran and Gill
 68361 Commercial Way
 Mandeville, LA 70471

FROM: David Dammon

SUBMITTAL No.: 28 31 00.01

REFERENCE: Office BuildOut Southern Interior Solutions
 DE Project: 2512

WE TRANSMIT:

- enclosed under separate cover _____

FOR YOUR:

- use record approval
- review and comment information drafting

THE FOLLOWING:

- drawing(s) contracts specifications
- shop drawings samples change order(s)
- product information warranty substitution request

# COPIES	DESCRIPTION	ACTION
E	Fire Alarm	A

- ACTION CODES:**
- A. Reviewed/No Exceptions
 - B. Reviewed/Exceptions Noted
 - C. Revise and Resubmit
 - G. Rejected
 - D. No Action Required
 - E. For Signature and Return to this Office
 - F. See Remarks Below

REMARKS:

SHOP DRAWING / SUBMITTAL REVIEW

~~XX~~ REVIEWED REVIEWED AS NOTED
 REVISE AND RESUBMIT REJECTED

Project No.: 2512 Submittal No.: 28 31 00.01

Corrections or comments made on the shop drawings during this review do not relieve the contractor from compliance with requirements of the drawings and specifications. This check is only for review of the general conformance with the design concept of the project and general compliance with the information given in the contract documents. This contractor is responsible for: confirming and correlating all quantities and dimensions; selecting fabrication processes and techniques of construction; coordinating his or her work with that and other trades and performing all in a safe and satisfactory manner.

By: David Dammon Date: 9/25/2025

DAMMON ENGINEERING, INC.

Slidell, LA



*ALARM DETECTION & SUPPRESSION SYSTEMS, LLC
NEW ORLEANS - BATON ROUGE – OCEAN SPRINGS*

30 VETERANS MEMORIAL BLVD., KENNER, LA 70062
TELEPHONE: (504) 471-0917 FAX: (504) 471-0924



FIRE ALARM submittal
332 N. NEW HAMPSHIRE
SIS OFFICE SPACE
COVINGTON, LA 70433

Date:09/19/2025

ADS Job# 6390

DESIGNED BY: WAYNE GUILLOT JR
SOLD BY: WAYNE LEVET



SECTION 1
Equipment List

SECTION 2
Data Sheets & Uls

SECTION 3
Battery Calculations

332 N. NEW HAMPSHIRE SIS OFFICE SPACE
COVINGTON, LA
ADS# 6390FA

30 VETERANS MEMORIAL BLVD KENNER, LA 70062
TELEPHONE: 504.471-0917 FAX: 504.471-0924
FIRE ALARM - SECURITY - VIDEO SURVEILLANCE - SOUND SYSTEMS
SERVICE - SALES - DESIGN- INSTALLATION

332N N. NEW HAMPSHIRE SIS OFFICE SPACE
FIRE ALARM EQUIPMENT LIST

<u>QTY</u>	<u>MODEL</u>	<u>DESCRIPTION</u>
EXISTING	NFW-100X	NOTIFIER INTELLIGENT FIRE ALARM CONTROL PANEL
EXISTING	NFC-50/100	NOTIFIER VOICE EVAC PANEL
01	NOT-BG12LX	NOTIFIER ADDRESSABLE PULL STATION
02	NP-200R	FIREWARDEN LOW PROFILE PHOTOELECTRIC SENSOR FOR DNR
02	DNR	HOUSING FOR DUCT CETECTOR
02	DST5	4-8 FOOT DUCT TUBE
02	NC-100R	NOTIFIER ADDRESSABLE RELAY MODULE
06	SPSCWLED	SYSTEM SENSOR CEILING MOUNT SPEAKER STROBE WHITE
04	SCWLED	SYSTEM SENSOR CEILING MOUNT STROBE WHITE

NFW-100X Intelligent Addressable FACP with Communicator

General

The **FireWarden-100X (NFW-100X)** is the latest intelligent addressable Fire Alarm Control Panel (FACP) within the FireWarden Series and is a direct replacement for the FireWarden-100 (NFW-100). The NFW-100X comes with a pre-installed communicator and supports up to 198 addressable devices (99 detectors and 99 modules). With an extensive list of powerful features, the NFW-100X programs just like FireWarden-100 products, yet fits into applications previously served only by conventional panels.

The pre-installed IPOTS-COM is a dual technology (POTS and IP) communicator. The POTS transmits system status (alarms, troubles, AC loss, etc.) to a Central Station via the public switched telephone network. The IP communicator's internet monitoring capability sends alarm signals over the Internet saving the monthly cost of two dedicated business telephone lines. Although not required, the secondary telephone line may be retained providing backup communication over the public switched telephone line. Optional cellular reporting is available using the CELL-MOD or CELL-CAB-N.

Remote and local programming of the control panel is possible using the FS-Tools Upload/Download utility. Programming databases can be uploaded/downloaded via the panel's USB port (and USB cable) or via an ethernet connection using the IPOTS-COM communicator. The USB port also allows for the download or upload of the entire program, history file, walk-test data, current status and system voltages by means of a USB flash drive.

The power supply and all electronics are contained on a circuit board supported on a new quick install chassis and housed in a metal cabinet. Available accessories include local and remote upload/download software, remote annunciators, and reverse polarity/city box transmitter (4XTM).

Features

- Listed to UL Standard 864, 10th edition
- Pre-installed IPOTS-COM Ethernet IP and POTS (Plain Old Telephone Service) Central Station Communicator over AlarmNet
- Optional CELL-MOD or CELL-CAB-N GSM Central Station Communicator over AlarmNet®
- Automated activation of the NFC-50/100 Emergency Command Center
- NFC-FFT Firefighter Telephone option
- Compatible with SWIFT® wireless devices
- Auto-programming (learn mode) reduces installation time. Reports two devices set to the same address
- Four built-in, independently programmable Style Z (Class A) or Style Y (Class B) NAC circuits
- Selectable strobe synchronization for System Sensor, Wheelock, and Gentex devices
- Notification Appliance Circuit End of Line resistor matching
- Four programmable function keys for ease of maintenance
- Two programmable relays and one fixed trouble relay
- Built-in Programmer
- Integral 80-character LCD display with backlighting
- Real-time clock/calendar with automatic daylight savings control
- History file with 1,000 event capacity
- Addressable sounder base compatibility
- Control module delay timer
- Automatic detector sensitivity testing (NFPA 72 compliant)
- Automatic device type-code verification
- Point trouble identification
- Waterflow selection per module point
- Alarm verification selection per detector point

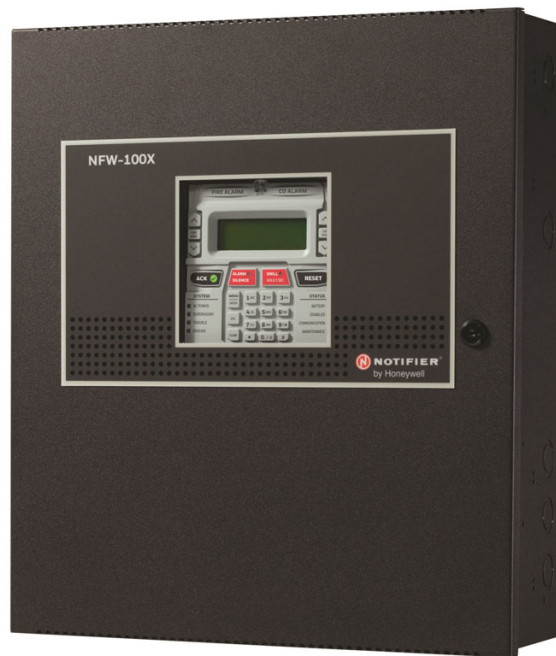

- Maintenance alert warns when smoke detector dust accumulation is excessive
- One-person audible or silent walk test with walk-test log and printout
- System alarm verification selection per detector point
- PAS (Positive Alarm Sequence) and Pre-signal per point (NFPA 72 compliant)
- Up to 16 ANN-BUS annunciators- 8 per each ANN-Bus
- Remote Acknowledge, Alarm Silence, Reset and Drill via addressable modules or remote annunciator
- Upload/Download of program and data via USB with optional FS-Tools Programming Utility

SLC COMMUNICATION LOOP

- Supports FlashScan® and CLIP protocols
- SLC operates up to 10,000 ft. (3,000 m) in FlashScan mode with twisted, unshielded wire
- Single addressable SLC loop which meets NFPA Class B and Class A requirements
- 198 addressable device capacity (99 addressable detectors and 99 modules)
- Compatible with NOTIFIER FireWarden and ONYX Series addressable devices (refer to the *FireWarden SLC Wiring Manual*)

NOTIFICATION APPLIANCE CIRCUITS (NACS)

- Four independently programmable output circuits. Circuits can be configured for the following outputs:
 - **Style Y** (Class B)
 - **Style Z** (Class A)
- Silence Inhibit and Autosilence timer options
- Continuous, March Time, Temporal, or California code for main circuit board NACs with two-stage capability
- Selectable strobe synchronization per NAC
- 2.5 A special application, 250mA regulated, total power for NACs

NOTE: Maximum or total 24VDC system power shared between all NAC circuits and the ANN-BUS is 2.7 A

PROGRAMMING AND SOFTWARE

- Autoprogramming (learn mode) reduces installation time
- Custom English labels (per point) may be manually entered or selected from an internal library file
- Two programmable Form-C relay outputs
- 99 software zones
- Continuous fire protection during online programming
- Program Check automatically catches common errors not linked to any zone or input point
- **OFFLINE PROGRAMMING:** Create the entire program in your office using FS-Tools, a Windows®-based software package, and upload/download system programming locally. Offline programming requires an ethernet connection. FS-Tools is available on www.notifier.com.

User interface

LED INDICATORS

- Fire Alarm (red)
- AC Power (green)
- Trouble (yellow)
- Battery fault (yellow)
- Maintenance (yellow)
- Alarm Silenced (yellow)
- CO Alarm (red)
- Supervisory (yellow)
- Ground fault (yellow)
- Disabled (yellow)
- Communication (yellow)
- F1-F4 Programmable Function Keys (yellow)

KEYPAD

- 16 key alpha-numeric pad
- Alarm Silence
- Four (4) programmable function keys
- Acknowledge
- Drill (Manual Evacuate)
- Reset (lamp test)

PRODUCT LINE INFORMATION

NFW-100X: Addressable Fire Alarm Control Panel with one SLC loop. Includes main circuit board with display chassis with transformer, backbox with door, plastic bag containing screws, cables, key, etc.

FS-Tools: Programming software for Windows®-based PC computer. Available for download at www.notifier.com.

CELL-CAB-N/CELL-MOD: Optional GSM communicators.

IPOTS-COM: Dual technology (POTS and IP) communicator. (replacement board)

DP-ES-R: Optional dress panel for the NFW-100X (red).

DP-ES-B: Optional dress panel for NFW-100X (black).

TR-CE-B: Optional trim ring for semi-flush mounting. (Black. For red, order **TR-CE**.)

BB-XP: Optional cabinet for one or two modules.

BB-25: Optional cabinet for up to six modules mounted on CHS-6 chassis.

BB-26: Battery backbox, holds up to two 25 AH batteries and CHG-75.

NFS-LBB: Battery box, houses two 55 AH batteries

CHS-6: Chassis, mounts up to six multi-modules in a BB-25 cabinet.

CHG-75: Battery charger for lead-acid batteries with a rating of 25 to 75 AH.

CHG-120: Remote battery charging system for lead-acid batteries with a rating of 55 to 120 AH. Requires additional NFS-LBB for mounting.

NOTE: CHG-120 or CHG-75 required for batteries larger than 18AH.

BAT Series: Batteries, see data sheet DN-6933.

PRN Series: UL listed compatible event printer. Uses tractor-fed paper.

OPTIONAL MODULES

4XTM Reverse Polarity Transmitter Module: Provides a super-

vised output for local energy municipal box transmitter, alarm and trouble. Includes a disable switch and disable trouble LED.

PWRMOD24 Power Expander Module: Optional power module. Increases alarm power output to 6 amps.

COMPATIBLE ANNUNCIATORS

N-ANN-80: Remote LCD annunciator mimics the information displayed on the FACP LCD display. Recommended wire type is unshielded. (Basic model is black; order -W for white; see DN-7114.)

N-ANN-100R: Remote LCD annunciator mimics the information displayed on the FACP LCD display. Recommended wire type is unshielded. For use in FM applications only. (Basic model is black; order R for red.)

N-ANN-I/O: LED Driver Module provides connections to a user supplied graphic annunciator. (See DN-7105.)

N-ANN-LED: Annunciator Module provides three LEDs for each zone: Alarm, Trouble, and Supervisory. Ships with red enclosure. (See DN-60242.)

N-ANN-RLED: Provides alarm (red) indicators for up to 30 input zones or addressable points. (See DN-60242.)

N-ANN-RLY: Relay Module provides 10 programmable Form-C relays. Can be mounted inside the cabinet. (See DN-7107.)

N-ANN-S/PG: Serial/Parallel Printer Gateway module provides a connection for a serial or parallel printer. (See DN-7103.)

ADDRESSABLE DEVICES

FSP-951: Addressable low-profile photoelectric smoke detector. FlashScan only.

FSP-951-IV: Addressable low-profile photoelectric smoke detector. Ivory. FlashScan and CLIP mode.

NP-200: Addressable low-profile photoelectric smoke detector. B300-6 base included, FlashScan only.

NP-200-IV: Addressable low-profile photoelectric smoke detector. Ivory, B300-6-IV base included. FlashScan and CLIP mode.

FSP-951T: Addressable low-profile photoelectric smoke detector with thermal sensor. FlashScan only.

FSP-951T-IV: Addressable low-profile photoelectric smoke detector with thermal sensor. Ivory. FlashScan and CLIP mode.

NP-200T: Addressable low-profile photoelectric smoke detector with thermal sensor. B300-6 base included. FlashScan only.

NP-200T-IV: Addressable low-profile photoelectric smoke detector with thermal sensor. Ivory, B300-6-IV base included. FlashScan and CLIP mode.

FSP-951R: Remote test capable addressable photoelectric smoke detector for use with DNR(W) duct detector housing. FlashScan only.

FSP-951R-IV: Remote test capable addressable photoelectric smoke detector for use with DNR(W) duct detector housing. Ivory. FlashScan and CLIP mode.

NP-200R: Remote test capable addressable photoelectric smoke detector for use with DNR(W) duct detector housing. FlashScan only.

NP-200R-IV: Remote test capable addressable photoelectric smoke detector for use with DNR(W) duct detector housing. Ivory, FlashScan and CLIP mode.

FST-951: Low-profile 135°F fixed thermal sensor. FlashScan only.

FST-951-IV: Low-profile 135°F fixed thermal sensor. Ivory. FlashScan and CLIP mode.

NH-200: Low-profile 135°F fixed thermal sensor. B300-6 base included, FlashScan only.

NH-200-IV: Low-profile 135°F fixed thermal sensor. Ivory. B300-6-IV base included, FlashScan and CLIP mode.

FST-951R: Low-profile, intelligent, rate-of-rise thermal sensor. FlashScan only.

FST-951R-IV: Low-profile, intelligent, rate-of-rise thermal sensor. Ivory. FlashScan and CLIP mode.

NH-200R: Low-profile 135°F fixed thermal sensor. B300-6 base included, FlashScan only.

NH-200R-IV: Low-profile 135°F fixed thermal sensor. Ivory. B300-6-IV base included, FlashScan and CLIP mode.

FST-951H: Low-profile intelligent 190°F/88°C fixed thermal sensor. FlashScan only.

FST-951H-IV: Low-profile intelligent 190°F/88°C fixed thermal sensor. Ivory. FlashScan and CLIP mode.

NH-200H: Low-profile intelligent 190°F/88°C fixed thermal sensor. B300-6 base included, FlashScan only.

NH-200H-IV: Low-profile intelligent 190°F/88°C fixed thermal sensor. Ivory. B300-6-IV base included, FlashScan and CLIP mode.

Legacy Devices

FSI-851: Addressable low-profile ionization smoke detector.

NI-100: Addressable low-profile ionization smoke detector.

FSP-851: Addressable low-profile photoelectric smoke detector.

NP-100: Addressable low-profile photoelectric smoke detector.

FSP-851T: Addressable low-profile photoelectric smoke detector with thermal sensor.

NP-100T: Addressable low-profile photoelectric smoke detector with thermal sensor.

FSP-851R: Remote test capable addressable photoelectric smoke detector for use with DNR(W) duct detector housing.

NP-100R: Remote test capable addressable photoelectric smoke detector for use with DNR(W) duct detector housing.

FST-851: Fast-response, low-profile heat detector.

NH-100: Fast-response, low-profile heat detector.

FST-851R: Fast-response, low-profile heat detector with rate-of-rise option.

NH-100R: Fast-response, low-profile heat detector with rate-of-rise option.

FST-851H: Fast-response, low-profile heat detector that activates at 190°F/88°C.

NH-100H: Fast-response, low-profile heat detector that activates at 190°F/88°C.

FAPT-851: Addressable low-profile multi-sensor detector.

NP-A100: Addressable low-profile multi-sensor detector.

B200S: Programmable, addressable sounder base.

B200SR: Addressable sounder base.

DNR: InnovairFlex low-flow non-relay duct-detector housing. (Order FSP-851R, FSP-951R, or NP-100R separately.)

DNRW: InnovairFlex low-flow non-relay duct-detector housing, with NEMA-4 rating. Watertight. (Order FSP-851R, FSP-951R, or NP-100R separately.)

Addressable Modules

FMM-1: Addressable Monitor Module for one zone of normally-open dry-contact initiating devices. Mounts in standard 4.0" (10.16 cm.) box. Includes plastic cover plate and end-of-line resistor. Module may be configured for either a Style B (Class B) or Style D (Class A) IDC.

NMM-100: Addressable Monitor Module for one zone of normally-open dry-contact initiating devices. Mounts in standard 4.0" (10.16 cm.) box. Includes plastic cover plate and end-of-line resistor. Module may be configured for either a Style B (Class B) or Style D (Class A) IDC.

FDM-1: Dual Monitor Module. Same as NMM-100 except it provides two Style B (Class B) only IDCs.

NDM-100: Dual Monitor Module. Same as NMM-100 except it provides two Style B (Class B) only IDCs.

FMM-101: Miniature version of NMM-100. Excludes LED and Style D option. Connects with wire pigtailed. May mount in device backbox.

NMM-100P: Miniature version of NMM-100. Excludes LED and Style D option. Connects with wire pigtailed. May mount in device backbox.

FZM-1: Similar to NMM-100. Addressable Monitor Module for one

zone of conventional two-wire detectors. Requires resettable 24 VDC power. Refer to the *Device Compatibility Document* for listed compatible devices and quantity limitation.

NZM-100: Similar to NMM-100. Addressable Monitor Module for one zone of conventional two-wire detectors. Requires resettable 24 VDC power. Refer to the *Device Compatibility Document* for listed compatible devices and quantity limitation.

FCM-1: Addressable Control Module for one Style Y/Z (Class B/A) zone of supervised polarized Notification Appliances. Mounts directly to a 4.0" (10.16 cm.) electrical box. NAC option requires external 24 VDC to power notification appliances.

NC-100: Addressable Control Module for one Style Y/Z (Class B/A) zone of supervised polarized Notification Appliances. Mounts directly to a 4.0" (10.16 cm.) electrical box. NAC option requires external 24 VDC to power notification appliances.

FRM-1: Addressable relay module containing two isolated sets of Form-C contacts, which operate as a DPDT switch. Mounts directly to a 4.0" (10.16 cm.) box, surface mount using the SMB500.

NC-100R: Addressable relay module containing two isolated sets of Form-C contacts, which operate as a DPDT switch. Mounts directly to a 4.0" (10.16 cm.) box, surface mount using the SMB500.

NBG-12LX: Addressable manual pull station with interface module mounted inside.

NOT-BG12LX: Addressable manual pull station with interface module mounted inside.

ISO-X: Fault Isolator Module.

N100-ISO: Fault Isolator Module.

ISO-6: Six-fault isolator module. Mount one or two modules in a BB-XP cabinet (optional). Mount up to six modules on a CHS-6 chassis in a CAB-3/CAB-4 series cabinet.

SMB500: Used to mount all modules except the FMM-101/NMM-100P.

NMM-100-10: Ten-input monitor module. Mount one or two modules in a BB-2F cabinet (optional). Mount up to six modules on a CHS-6 chassis in a BB-6F cabinet.

NZM-100-6: Six-zone interface module. Mount one or two modules in a BB-XP cabinet (optional). Mount up to six modules on a CHS-6 chassis in a CAB-3/CAB-4 series cabinet.

SWIFT Wireless Devices

FWSG: Wireless Gateway

FWD-200P: intelligent, wireless photo detector.

FWH-200ROR135: LiteSpeed intelligent wireless rate of rise (135°) heat detector.

FWD-200ACCLIMATE: Wireless Acclimate Detector

FWH-200FIX135: intelligent wireless fixed-temperature (135°) heat detector.

FW-MM: Intelligent wireless monitor module.

FW-RM: Intelligent wireless relay module.

NBG-12LW: Intelligent wireless pull station.

WAV-RL, WAV-WL, WAV-CRL, WAV-CWL: Intelligent AV bases.

W-USB: Wireless USB radio/antenna dongle that plugs into the USB port of a PC running SWIFT Tools.

SWIFT Tools: Programming and diagnostic utility for the Wireless Gateway and devices. Available for download from firelite.com.

NOTE: For more information on Compatible Addressable Devices for use with the FireWarden-100X, see the following data sheets (document numbers): NP-200 Series (DN-60979), NH-200 Series (DN-60980), FSP-851 Series (DN-6935), FSP-951 Series (DN-60977), FST-851 Series (DN-6936), FST-951 Series (DN-60975), FAPT-851 (DN-6937), N100-ISO (DN-6994), NP-100 series (DN-6995), NH-100/NH-100R (DN-6997), DNR/InnovairFlex (DN-60424, DN-60429), NP-A100 (DN-6998), NMM-100/NMM-100P/NDM-100/NZM-100 (DN-6999), NC-100 (DN-7000), NC-100R (DN-60383), NMM-100-10 (DN-6990), MM-1/FDM-1/FZM-1/FMM-101 (DN-6720), FCM-1/FRM-1 (DN-6724), NOT-BG12LX (DN-7001), NBG-12LX (DN-6726), and FireWarden SLC Manual (52304).

System Capacity

- Intelligent Signaling Line Circuits..... 1
- Addressable device capacity 198
- Programmable software zones 99
- Annunciators..... 16

Electrical Specifications

AC Power: Operates in either 120 or 240 VAC, 50/60 Hz, 3.25 A, auto-sensing- no switch required. Wire size: minimum 14 AWG (2.00 mm2) with 600 V insulation. Nonpower-limited, supervised.

Battery: Two 12 V 18 AH lead-acid batteries. Battery Charger Capacity: 7-18 AH (FireWarden-100X cabinet holds maximum of two 18 AH batteries.)

Communication Loop: Supervised and power-limited.

Notification Appliance Circuits: Terminal Block provides connections for four NACs, Style Y (Class B) or Style Z (Class A). Special Application power. Power-limited, supervised circuitry. Maximum signaling current per circuit: 2.5 amps special application, 250mA regulated. End-of-Line Resistor: 4.7k ohm, ½ watt (P/N 71252 UL listed) for Style Y (Class B) NAC; system capable of 1.9 kΩ - 22 kΩ ELR range. Refer to the *NOTIFIER Device Compatibility Document* for listed compatible devices.

Two Programmable Relays and One Fixed Trouble Relay: Contact rating: 2.0 A @ 30 VDC (resistive), 0.5 A @ 30 VAC (resistive). Form-C relays, non-power-limited, non-supervised.

Cabinet Specifications

Door: 19.26" (48.92 cm.) high x 16.82" (42.73 cm.) wide x 0.72" (1.82 cm.) deep. **Backbox:** 19.00" (48.26 cm.) high x 16.65" (42.29 cm.) wide x 5.25" (13.34 cm.) deep. **Trim Ring (TR-CE/B):** 22.00" (55.88 cm.) high x 19.65" (49.91 cm.) wide.

Shipping Specifications

Weight: 26.9 lbs. (12.20 kg.) **Dimensions:** 20.00" (50.80 cm.) high x 22.5" (57.15 cm.) wide x 8.5" (21.59 cm.) deep.

Temperature and Humidity Ranges

This system meets NFPA requirements for operation at 0 – 49°C/32 – 120°F and at a relative humidity 93% ± 2% RH (noncondensing) at 32°C ± 2°C (90°F ± 3°F). However, the useful life of the system's standby batteries and the electronic components may be adversely affected by extreme temperature ranges and humidity. Therefore, it is recommended that this system and its peripherals be installed in an environment with a normal room temperature of 15 – 27°C/60 – 80°F.

Addressable Device Accessories

End-of-Line Resistor Assembly (R-47K and R-3.9K): The 47k ohm assembly supervises the NMM-100-10, NDM-100, NMM-100P, and NC-100 module circuits. The 3.9k ohm assembly supervises the NZM-100-6 module circuit. These resistors are included with each module.

Power Supervision Relay: Supervises the power to 4-wire smoke detectors and notification appliances.

Wiring Requirements

While shielded wire is not required, it is recommended that all SLC wiring be twisted-pair to minimize the effects of electrical interference. Refer to the panel manual for wiring details.

NFPA Standards

The FireWarden-100X complies with the following NFPA 72 Fire Alarm Systems requirements:

- **LOCAL** (Automatic, Manual, Waterflow and Sprinkler Supervisory).
- **AUXILIARY** (Automatic, Manual and Waterflow) (requires 4XTM).
- **REMOTE STATION** (Automatic, Manual and Waterflow) (Where a DACT is not accepted, the alarm, trouble and supervisory relays may be connected to UL 864 listed transmitters. For reverse polarity signaling of alarm and trouble, 4XTM is required.)
- **PROPRIETARY** (Automatic, Manual and Waterflow).
- **CENTRAL STATION** (Automatic, Manual and Waterflow, and Sprinkler Supervised).
- **OT, PSDN** (Other Technologies, Packet-switched Data Network)
- **IBC 2012, IBC 2009, IBC 2006, IBC 2003, IBC 2000** (Seismic).
- **CBC 2007** (Seismic)

Agency Listings and Approvals

The listings and approvals below apply to the basic FireWarden-100X control panel. In some cases, certain modules may not be listed by certain approval agencies, or listing may be in process. Consult factory for latest listing status.

- **UL:** S635
- **CSFM:** 7165-0028:0505
- **FDNY:** COA #6268



This document is not intended to be used for installation purposes.
 We try to keep our product information up-to-date and accurate.
 We cannot cover all specific applications or anticipate all requirements.
 All specifications are subject to change without notice.

NOTIFIER

12 Clintonville Road
 Northford, CT 06472
 203.484.7161
 www.notifier.com

AlarmNet®, NOTIFIER®, FireWarden®, SWIFT®, and System Sensor® are registered trademarks of Honeywell International Inc. Microsoft® and Windows® are registered trademarks of the Microsoft Corporation.

©2018 by Honeywell International Inc. All rights reserved. Unauthorized use of this document is strictly prohibited.

Country of Origin: USA





UOJZ.S635 - CONTROL UNITS, SYSTEM

Control Units, System

See General Information for Control Units, System

NOTIFIER

12 Clintonville Rd
Northford, CT 06472-1610 USA

S635

UL 864 10th Edition Listed

Model	Control Unit System Type(s)	Initiating Device Type(s)	Signaling Type(s)
FireWarden-100X	AUX	A, M, WF	Rev Pol
	L	A, CO, M, SS, WF	March, NC, T4
	RS (PPU)	A, CO, M, SS, WF	DAC, PB, Rev Pol
	P (PPU)	A, CO, M, SS, WF	DAC, PB, Rev Pol
	CS (PPU)	A, CO, M, SS, WF	DAC, PB, Rev Pol
FireWarden-50X	AUX	A, M, WF	Rev Pol
	L	A, CO, M, SS, WF	March, NC, T4
	RS (PPU)	A, CO, M, SS, WF	DAC, PB, Rev Pol
	P (PPU)	A, CO, M, SS, WF	DAC, PB, Rev Pol
	CS (PPU)	A, CO, M, SS, WF	DAC, PB, Rev Pol
NFS2-3030 # (f) (c), NFS2-3030E # (f) (c), XLS3000 # (f) (c)	L	A, M, SS, WF	C, NC
	AUX	A, M, WF	NC
	RS (PPU)	A, M, SS, WF	DAC, PB, Rev Pol
	CS (PPU)	A, M, SS, WF	DAC, NC, PB
	P (PPU)	A, M, SS, WF	DAC, MX, NC, PB
NFS2-640 (R) # (g) (c), NFS2-640E (R) (c) # (g), NFS-320 (R) # (g), NFS-320E/C (R) # (g) (c), NFS-320SYS/(E)(-FR) # (g) (c)			
	L	A, M, SS, WF	C, MX, NC
	AUX	A, M, WF	NC
	RS (PPU)	A, M, SS, WF	DAC, PB, Rev Pol

	CS (PPU)	A, M, SS, WF	DAC, MX, NC, PB
	P (PPU)	A, M, SS, WF	DAC, MX, NC, PB
NFW-100X	AUX	A, M, WF	Rev Pol
	L	A, CO, M, SS, WF	March, NC, T4
	RS (PPU)	A, CO, M, SS, WF	DAC, PB, Rev Pol
	P (PPU)	A, CO, M, SS, WF	DAC, PB, Rev Pol
	CS (PPU)	A, CO, M, SS, WF	DAC, PB, Rev Pol
NFW-50X	AUX	A, M, WF	Rev Pol
	L	A, CO, M, SS, WF	March, NC, T4
	RS (PPU)	A, CO, M, SS, WF	DAC, PB, Rev Pol
	P (PPU)	A, CO, M, SS, WF	DAC, PB, Rev Pol
	CS (PPU)	A, CO, M, SS, WF	DAC, PB, Rev Pol

UL 864 9th Edition Listed

Model	Control Unit System Type(s)	Initiating Device Type(s)	Signaling Type(s)
Firewarden-100 (d)	L	A, M, SS, WF	March, NC
	AUX	A, M, WF	NC
	RS (PPU)	A, M, SS, WF	C
	RS (PPU)	A, M, SS, WF	Rev Pol
	RS (PPU)	A, M, SS, WF	DAC, OT
	P (PPU)	A, M, SS, WF	C, DAC, OT
	CS (PPU)	A, M, SS, WF	DAC
Firewarden-100-2 (d), Firewarden 100-2E (d)	L	A, M, SS, WF	March, NC
	AUX	A, M, WF	NC
	RS (PPU)	A, M, SS, WF	C
	RS (PPU)	A, M, SS, WF	Rev Pol

	RS (PPU)	A, M, SS, WF	DAC, OT
	P (PPU)	A, M, SS, WF	C, DAC, OT
	CS (PPU)	A, M, SS, WF	DAC, OT
FireWarden-50 (e), FireWarden-50E (e)	L	A, M, SS, WF	C, March, NC
	AUX	A, M, WF	NC
	RS (PPU)	A, M, SS, WF	DAC, NC, OT, Rev Pol
	P (PPU)	A, M, SS, WF	C, DAC, OT
	CS (PPU)	A, M, SS, WF	DAC, OT
NCS5-W-ONYX, NCS5-F-ONYX	CS, P (RU)	A, M, SS, WF	MX
NFW-100 (d)	L	A, M, SS, WF	March, NC
	AUX	A, M, WF	NC
	RS (PPU)	A, M, SS, WF	C
	RS (PPU)	A, M, SS, WF	Rev Pol
	RS (PPU)	A, M, SS, WF	DAC, OT
	P (PPU)	A, M, SS, WF	C, DAC, OT
	CS (PPU)	A, M, SS, WF	DAC
NFW-50 (e), NFW-50E (e)	L	A, M, SS, WF	C, March, NC
	AUX	A, M, WF	NC
	RS (PPU)	A, M, SS, WF	DAC, NC, OT, Rev Pol
	P (PPU)	A, M, SS, WF	C, DAC, OT
	CS (PPU)	A, M, SS, WF	DAC, OT

NFW2-100 (d), NFW2-100E (d)	L	A, M, SS, WF	March, NC
	AUX	A, M, WF	NC
	RS (PPU)	A, M, SS, WF	C
	RS (PPU)	A, M, SS, WF	Rev Pol
	RS (PPU)	A, M, SS, WF	DAC, OT
	P (PPU)	A, M, SS, WF	C, DAC, OT
	CS (PPU)	A, M, SS, WF	DAC, OT
NSP-25, NSP-25E	AUX	A, M, WF	-
	L	A, M, SS, WF	C, NC
	RS (PPU)	A, M, SS, WF	DAC, OT, Rev Pol
	CS (PPU)	A, M, SS, WF	DAC, OT
RP-1001*	L	A, M, SS, WF	NC
	AUX	A, M, WF	NC
	RS (PPU)	A, M, WF	NC
	RS (PPU)	A, M, WF	DAC
	P (PPU)	A, M, WF	NC
	CS (PPU)	A, M, WF	DAC
RP-1002*, RP-1002E*	L	A, M, SS, WF	NC
	AUX	A, M, WF	NC
	RS (PPU)	A, M, WF	NC
	RS (PPU)	A, M, WF	DAC
	P (PPU)	A, M, WF	NC
	CS (PPU)	A, M, WF	DAC
RP-2001 (2)(h), RP-2001E (2)(h), RP-2002 (2)(h), RP-2002E (2)(h)	L	A, M, SS, WF	March, NC

	AUX	A, M, WF	NC
	RS (PPU)	A, M, SS, WF	DAC, NC, Rev Pol
	P (PPU)	A, M, WF	C, DAC
	CS (PPU)	A, M, SS, WF	DAC
S5000 #(b)	AUX, L, P (PPU), RS (PPU)	A, M, SS, WF	C, NC
	CS (PPU)	A, M, WF	C, DAC, NC
	CS, RS (PPU)	A, M, SS, WF	DAC
	RS (PPU)	SS	Rev Pol
S5000E (b)	CS (PPU)	A, M, WF	C, DAC, NC
	CS, RS (PPU)	A, M, SS, WF	DAC
	RS (PPU)	SS	Rev Pol
SFP-2402 (a)	L	A, M, SS, WF	March, NC
	P (PPU)	A, M, SS, WF	C
	CS (PPU)	A, M, SS, WF	DAC
SFP-2402E (i), SFP-2404E (i)	L	A, M, SS, WF	March, NC
	AUX	A, M, WF	NC
	P (PPU)	A, M, SS, WF	C
	CS (PPU)	A, M, SS, WF	DAC
SFP-2404 (i)	L	A, M, SS, WF	March, NC
	AUX	A, M, WF	NC
	RS (PPU)	A, M, SS, WF	Rev Pol
	P (PPU)	A, M, SS, WF	C
	CS (PPU)	A, M, SS, WF	DAC

SFP-400*(j), SFP-400B*(j)	L	A, M, SS, WF	NC
	AUX	A, M, WF	NC
	RS (PPU)	A, M, SS, WF	Rev Pol
	RS (PPU)	A, M, WF	DAC
	P (PPU)	A, M, WF	NC
	CS (PPU)	A, M, WF	DAC
SFP-5UD (1)(h), SFP-10UD (1)(h), SFP-5UDE (1)(h), SFP-10UDE (1)(h), SFP-10UDC (1)(h), SFP-5UDC (1)(h)			
	L	A, M, SS, WF	March, NC
	AUX	A, M, WF	NC
	RS (PPU)	A, M, SS, WF	DAC, NC, OT, Rev Pol
	CS (PPU)	A, M, SS, WF	DAC, OT
	P (PPU)	A, M, SS, WF	C, DAC, OT
SGL-404	CS (PPU)	A, M, WF	NC
	AUX, L	A, M, SS, WF	NC
	RS (PPU)	A, M, WF	NC
XP Transponder #	L	A, M, WF	NC
	AUX, P (PPU)	A, M, WF	MX, NC

UL 864 10th Edition Listed

Subassembly, Model(s) AMPS-24 Power Supply, AMPS-24E Power Supply, BDA-25V Backup Digital Audio Amplifier, BDA-70V Backup Digital Audio Amplifier, CAB-AA4(n), CPS-24 Power Supply, CPS-24E Power Supply, CPU2-3030D CPU Board with Display, CPU2-640 Central Processing Unit Board, CPU2-640E Central Processing Unit Board, DAA-PS Power Supply, DS-FM, DS-RFM, DS-SFM Fiber Conversion Module, DVC, DVC-EM, DVC-EMF, DVC-EMSF Digital Voice Command, DVC-AO Audio Output Board, DVC-KD Keypad Board, LCM-320 Loop Control Module, LEM-320 Loop Expander Module, NCD Network Control Display, NCM-F, NCM-W Network Control Module, NCM-W Network Control Module, TM-4 Transmitter Module

Subassembly, amplifier, Model(s) AA-100, AA-100E, AA-120, AA-120E, AA-30, AA-30E

Subassembly, backbox, Model(s) SBB-A4(l), SBB-B4(l), SBB-C4(l), SBB-D4(l)

Subassembly, battery holder chassis, Model(s) CHS-BH1

Subassembly, chassis, Model(s) CHS-2D, CHS-4L, CHS-4N, CHS-M2, CHS-M3

Subassembly, door, Model(s) ADDR-B4(l), ADDR-C4(l), ADDR-D4(l), DR-A4(l), DR-AA4, DR-AA4BR, DR-AA4R, DR-B4(l), DR-C4(l), DR-D4(l), DR-PS1, EQDR-B4(l), EQDR-C4(l), EQDR-D4(l)

Subassembly, dress panel, Model(s) ADP-4B, BM-1B, BP-4, BP2-4, DP-1B, DP-DISP, DP-GDIS1, DP-GDIS2, DPA-1, DPA-1A4, DPA-2, DPDW-1B, DPSW-1B, MP-1B, VP-2B

Subassembly, enclosure, Model(s) ABF-1(m), ABF-2(m), ABF-4(l), ABS-1(l), ABS-1T(l), ABS-2(l), ABS-2D(l), ABS-4D(l), ABS-8R, ABS-TD, BB-100, BB-100R, BB-200, BB-200R, BB-UZC, CA-1, CA-2, CAB-A4(l), CAB-B4(l), CAB-C4(l), CAB-D4(l), CAB-PS1, CAB-RP, CAB-RPR, EQBB-B4(l), EQBB-C4(l), EQBB-D4(l), SBB-AA4, SBB-AA4B, SBB-AA4R

Subassembly, microphone chassis, Model(s) CMIC-1

UL 864 9th Edition Listed

Battery Boxes, Model(s) BB-17

Control Unit Subassemblies - Intended for use with compatible control units as described in the control unit installation manual, Model(s) N-CAC-5X (1) class A converter module

Fire Alarm System Enclosures, Model(s) NFS-LBRR

Proprietary System Ancillary Display, Model(s) NWS, NWS-2, NWS-3, ONYXWeb

Subassembly, Model(s) 4XLM LED Interface Module, 4XTM Transmitter Module, 4XZM Zone Relay Module, BacNet-GW-3 Interface, CMIC-RP Microphone, CPU2-3030ND CPU Board without Display, DS-AMP/E Digital Amplifier, DS-DB Distribution Board, DS-XF70V Audio Transformer, DVC-RPU Remote Paging Unit, GW-WEBPORTAL Supplementary Network Bridge, KAPS-24 Power Supply, KDM-R2 Keyboard Display Module, MODBUS-GW Interface, N-WEBPORTAL Supplementary Network Bridge, SK-WEBPORTAL Supplementary Network Bridge, Vesda-HLI-GW Interface

AUX - Auxiliary System

A - Automatic Fire Alarm: thermostats, smoke detectors, etc.

M - Manual Fire Alarm: manually operated boxes

WF - Waterflow Alarm: waterflow switches

Rev Pol - Reverse Polarity

L - Local System

CO - Carbon Monoxide Alarm: carbon monoxide detectors

SS - Supervisory: gate valves, water-level switches, temperature switches, carbon monoxide alarm, residential fire alarm control units, etc.

March - March Time

NC - Noncoded, Steady, Temporal 3 Pattern, etc.

T4 - Temporal 4 Pattern

RS (PPU) - Remote Station System (Protected Premises Unit)

DAC - Digital Alarm Communicator

PB - Performance Based Technologies

P (PPU) - Proprietary System (Protected Premises Unit)

CS (PPU) - Central Station System (Protected Premises Unit)

C - Coded

MX - Multiplex

OT - Other Transmission Technologies

CS - Central Station System

P (RU) - Proprietary System (Supervising Station Receiving Unit)

- When Local (L) Type, System control unit with additional emergency voice communication, emergency telephone communication and paging.

(1) - Models are complementary Listed to FSZI, SYZV and QVAX.

(2) - Models are complementary Listed to FSZI, SYZV and QVAX when the System Type is Local.

(a) - When the Type Signaling is Coded (C) or Digital Alarm Communicator (DAC), see footnote +.

(b) - When Central Station (PPU) Type or Type Signaling is Digital Alarm Communicator (DAC), see footnote +.

(c) - When type signaling is OTHER TECHNOLOGIES, see footnote +

- (d) - When Type Signaling is Digital Alarm Communicator (DAC), Coded (C) or Other Technologies (OT) see footnote +. When Type Signaling is Reverse Polarity - requires separately Listed Model 4XTMF transmitter module.
- (e) - Noncoded (NC) or Coded (C) Type Signaling (except when Type is Local (L) Rev. Pol. Type Signaling, see footnote +.
- (f) - When Type Signaling is Coded (C), Digital Alarm Communicator (DAC) or Reverse Polarity, see footnote +.
- (g) - When Type Signaling is Coded (C), see footnote +.
- (h) - When Type is Auxiliary or Type Signaling is Reverse Polarity- requires separately Listed Model 4XTMF transmitter Module. When the Type is any Protected Premises Unit (PPU) and the Type Signaling is Coded (C), Non Coded (NC) or Digital Alarm Communicator (DAC), see footnote +.
- (i) - When the Type is Auxiliary or the Type Signaling is Coded (C) or Digital Alarm Communicator (DAC), see footnote +.
- (j) - When Type Signaling is Reverse Polarity, see footnote +.
- (l) - May include /R, /F or /B suffix.
- (m) - May include /R, /F, /B or /D suffix.
- (n) - The CAB-AA4 backbox Series is made up of the SBB-AA4, SBB-AA4R, SBB-AA4B, SBB-AA4BR enclosures, and the DR-AA4, DR-AA4B, DR-AA4R, DR-AA4BR Doors.
- * - Protected Premises Unit when installed and interconnected with additional Listed equipment as described in the units installation instructions.
- + - Must be employed with additional specific Listed device(s) as indicated in installation instructions and wiring diagrams to provide indicated type service. The installation instructions for the Other Transmission Technologies transmitter will specify the compatible Notifier control unit model.

Last Updated on 2019-11-13

The appearance of a company's name or product in this database does not in itself assure that products so identified have been manufactured under UL's Follow-Up Service. Only those products bearing the UL Mark should be considered to be Certified and covered under UL's Follow-Up Service. Always look for the Mark on the product.

UL permits the reproduction of the material contained in the Online Certification Directory subject to the following conditions: 1. The Guide Information, Assemblies, Constructions, Designs, Systems, and/or Certifications (files) must be presented in their entirety and in a non-misleading manner, without any manipulation of the data (or drawings). 2. The statement "Reprinted from the Online Certifications Directory with permission from UL" must appear adjacent to the extracted material. In addition, the reprinted material must include a copyright notice in the following format: "© 2020 UL LLC"

NOTIFIER FirstCommand

NFC-50/100(E)



Voice Evacuation & Emergency Communications System

General

Notifier's First Command NFC-50/100 and NFC-50/100E are multipurpose emergency voice evacuation panels for fire applications, mass notification applications, or both. The First Command delivers 50 or 100 watts of audio power for distribution to up to eight speaker circuits (i.e. zones). The NFC-50/100(E) comes standard with a single speaker circuit and a built-in 50 watt, 25V amplifier. A secondary 50 watt amplifier (NFC-BDA-25/70V) can be added for single speaker circuit backup or to increase system capacity to two speaker circuits and an additional 50 watts of audio power. An optional NFC-CE6 module added to the NFC-50/100(E) will upgrade the system to a maximum of eight speaker circuit outputs. All speaker output circuits can be wired in either Style Y (Class B) or Style Z (Class A) configuration. The NFC-50/100(E) has fourteen field programmable messages (up to 60 seconds each), built-in field configurable pre- and post-announce tone generators and a fully supervised Notification Appliance Circuit (NAC) with 2.0 amps of synchronized NAC power. The NFC-50/100(E) includes three built-in Form-C relay contacts, (AC power, trouble and MNS active) a NAC follower and 500mA special application power. A built-in power supply delivers operational power and an onboard battery charger supports charging up to 26AH batteries (NFC cabinet holds up to 18AH batteries).

For fire protection applications, the NFC-50/100(E) is an adjunct (slave) to any UL listed FACP, providing reverse polarity or contact closure; can be used as a stand-alone unit for non-fire applications. For seamless integration between fire and mass notification, the NFC-50/100(E) can be directly activated via serial communication between the NFW2-100(Rev 3), NFS-320 or NFS2-640. Activation of the NFC-50/100(E) via other FACP's uses the eight on board Command Input Circuits (CMD's). Two of the eight CMD circuits (CMD 1 & CMD 2) can be individually field programmed for activation by an FACP Notification Appliance Circuit reverse polarity and all eight can be activated by a contact closure. In addition, the NFC-50/100(E) can be activated from a building's Private Branch Exchange (PBX) with the integral night ring feature.

All NFC-50/100(E) programming is done by using a simple, built-in programming utility accessed from any laptop. For added flexibility, the NFC-50/100(E) supports both 25V and 70V speaker output operation. By adding a 70V transformer conversion module (NFC-XRM-70V) or an additional 70 volt secondary amplifier (NFC-BDA-25/70V) the system supports 70 volt speaker devices.

The NFC-50/100(E) can expand in order to accommodate larger or more complex installations. To add more control and increase system capacity, any combination of up to eight external remote consoles (including the NFC-LOC, NFC-RPU, and NFC-RM) and up to eight distributed audio amplifiers (including the NFC-50DA(E), NFC-100DA(E) and NFC-125-DA(E) can be connected on the external data bus and audio riser data bus to create a fully integrated command center. A fully loaded system supports up to 1100 watts of total audio power and up to 24 speaker circuit outputs.

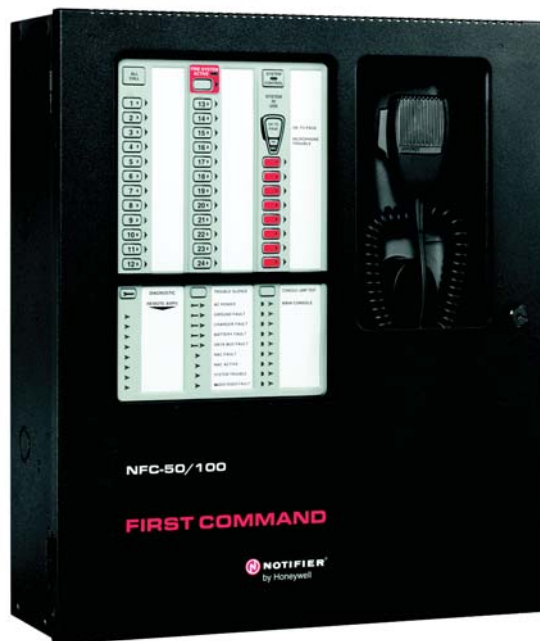

TYPICAL APPLICATIONS

- Schools
- Theaters
- Auditoriums
- Nursing Homes
- Military facilities
- Places of Worship
- Factories
- Restaurants
- Office Buildings

Features

- UL Listed to UL 2572 Communication (Control Units Mass Notification Systems) and UL 864 (emergency voice evacuation for fire).
- Modular design for system flexibility and easy expansion.
- Removable terminal blocks.
- 50 watts of 25V audio power (expandable to 100 watts) RMS.
- 2 amp Notification Appliance Circuit (NAC) output, sync generator, or follower for System Sensor, Wheelock or Gen-tex protocols.
- Optional 70V transformer available for the primary amplifier. (Note that speaker wiring continues to be supervised in standby, alarm and when background music is playing with this optional transformer installed).
- Eight Command Input Circuits to activate messages 1 to 8:
 - CMD1 and CMD2 are field selectable to be activated from 12 or 24 VDC Notification Appliance Circuits (reverse polarity) or contact closures.
 - CMD3-CMD8 are activated by contact closures.
- Speaker Circuits.
 - Single Style Y (Class B) or Style Z (Class A) speaker Circuit.

- Two Style Y (Class B) or Style Z (Class A) speaker circuits (with optional NFC-BDA-25/70V Audio Amplifier installed).
- Eight Style Y (Class B) or Style Z (Class A) speaker circuits (with optional NFC-BDA-25/70V and NFC-CE6 installed).
- 520Hz square wave tones available, which can be uploaded to the NFC-50/100 to meet NFPA Low Frequency requirements. (*Refer to the Device Compatibility Document 15378 for listed compatible speakers.*)
- NFC-50/100(E) can be controlled by an FACP via the ANN/ACS (EIA-485) link of the NFW2-100 (Rev 3), and via the ACS (EIA-485) link of the NFS-320 or NFS2-640. The NFS-320 or NFS2-640 must be firmware version 20.0 or higher.
- Integral supervised microphone.
- Microphone time-out feature which reverts back to pre-recorded message if emergency page exceeds the programmed time.
- 14 recorded messages.
- Field-selectable message and custom message recording capability using the local microphone, a USB port, or an external audio input.
- External Audio Input can be used for background music.
- Up to 60 second message duration for all messages.
- Integral tone generators field selectable for multiple tone types.
- Powered by integral AC power supply or batteries during AC fail.
- Programmable delay of immediate, 2 hours or 6 hours reporting of AC Loss.
- Piezo sounder for local trouble.
- 100 event history log.
- Three Form-C relays:
 - AC Power Loss Relay - TB1.
 - System Trouble Relay - TB2.
 - MNS Active - TB3.
- 500mA (0.5A) Special Application (auxiliary power) output for addressable modules when interfaced with compatible addressable FACP's and End-of-Line power supervision relays.
- System Status LEDs (refer to "Controls and Indicators" in product manual LS10001-001NF-E).
- Integral Dress Panel.
- Optional TR-CE-B semi-flush trim ring.
- Any combination of up to eight (8) external remote consoles:
 - Optional NFC-RM Remote Microphone (includes cabinet). See DN-60778.
 - Optional NFC-RPU Remote Page Unit (includes cabinet). See DN-60775.
 - Optional NFC-LOC Local operator console (includes cabinet). See DN-60777.
- Any combination of up to eight (8) distributed audio amplifiers:
 - Optional NFC-50DA(E) distributed amplifier, 50 watts. See DN-60776.
 - Optional NFC-125DA(E) distributed amplifier, 125 watts. See DN-60776.
 - Optional NFC-50/100 distributed amplifier with backup capability, 50/100 watts. See DN-60776.

Optional Internal Expansion Modules

NFC-CE6: Circuit Expander Module provides connections for up to six Style Z (Class A) or Style Y (Class B) speaker circuits. Circuits are configured through the web-based programming utility.

NFC-BDA-25V: 25V, 50 watt audio amplifier module. Adding a second speaker circuit increases the total NFC-50/100 power output to 100 watts or can also be used as a backup amplifier.

NFC-BDA-70V: 70V, 50 watt audio amplifier module. Adding a second speaker circuit increases the total NFC-50/100 power output to 100 watts or can also be used as a backup amplifier.

NFC-XRM-70V: 70V Transformer Conversion Module. Converts the NFC-50/100(E) primary amplifier to a 70V output. This transformer mounts directly to the NFC-50/100(E) main control board by two metal brackets.

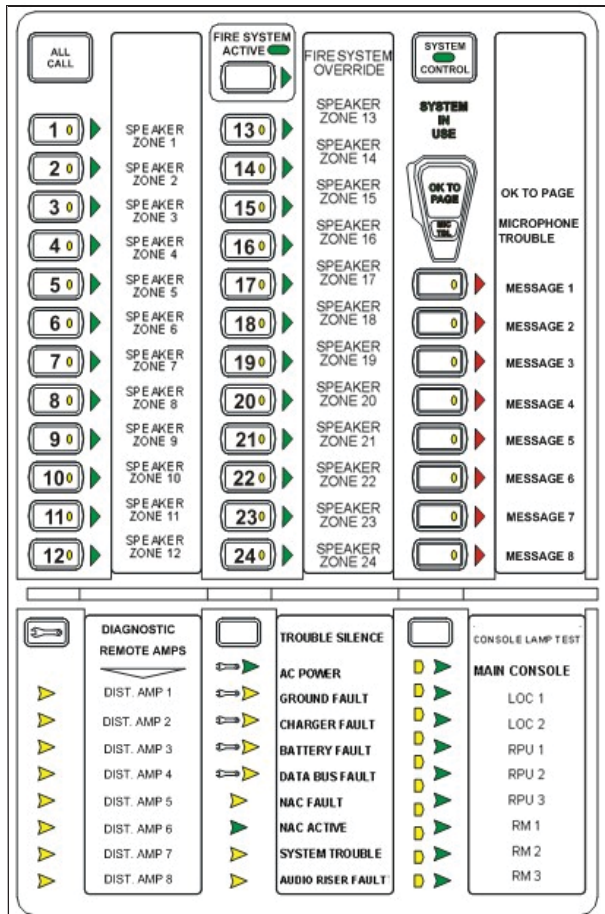

Control and Indicators

PUSH BUTTON CONTROLS

- All Call
- MNS Control
- System Control
- Speaker Select 1-24
- Message Select 1-14
- Diagnostic Select
- Trouble Silence
- Console Lamp Test

LED Status Indicators (visible with door closed)

- Fire System Active (green)
- MNS Control (green)
- System Control (green)
- System in Use (green)
- Speaker Zone 1-24 Active (green)
- Speaker Zone 1-24 Fault (yellow)
- OK to Page (green)
- Microphone Trouble (yellow)
- Message 1-8 Active (red)
- Message 1-8 Fault (yellow)
- Remote Amplifier 1-8 Fault (yellow)
- LOC/RPU/RM 1-8 Active (green)
- Main Console Fault (yellow)
- AC Power (green)
- Ground Fault (yellow)
- Charger Fault (yellow)
- Battery Fault (yellow)
- Data Bus Fault (yellow)
- NAC Fault (yellow)
- NAC Active (green)
- System Trouble (yellow)
- Audio Riser Fault (yellow)
- LOC/RPU/RM 1-8 Fault (yellow)

LED Indicators (visible with door and dress panel open)

- Speaker Volume Control Fault (yellow).
- Option Card Fault (yellow).
- Amplifier Over Current Fault (yellow).

Product Line Information

NFC-50/100: (Primary Operating Console) 50 Watt, 25V single speaker zone emergency voice evacuation system, integral microphone, built in tone generator and 14 recordable messages.

NFC-50/100E: Export version (Primary Operating Console) 50 Watt, 25V single speaker zone emergency voice evacuation system, integral microphone, built in tone generator and 14 recordable messages. (240 VAC, 50Hz).

NFC-CE6: Speaker Circuit/Zone Expander Module.

NFC-BDA-25V: 25V, 50 watt audio amplifier module. Adding a second speaker circuit increases the total NFC-50/100 power output to 100 watts or can also be used as a backup amplifier.

NFC-BDA-70V: 70V, 50 watt audio amplifier module. Adding a second speaker circuit increases the total NFC-50/100 power output to 100 watts or can also be used as a backup amplifier.

NFC-XRM-70V: 70V Transformer Conversion Module. Converts the NFC-50/100(E) primary amplifier to a 70V output. This transformer mounts directly to the NFC-50/100(E) main control board by two metal brackets.

NFC-LOC: Local Operator Console (Complete user interface), *Please refer to the data sheet DN-60777 for more information.*

NFC-RPU: Remote Page Unit Hand held microphone, 14 message buttons. *Please refer to the data sheet DN-60775 for more information.*

NFC-RM: Remote Microphone only. *Please refer to the data sheet DN-60778 for more information.*

NFC-50DA: Distributed (Remote) Audio Amplifier, 50 watts. *Please refer to the data sheet DN-60776 for more information.*

NFC-50DAE: Export version. Distributed (Remote) Audio Amplifier, 50 watts. (240 VAC, 50Hz). *Please refer to the data sheet DN-60776 for more information.*

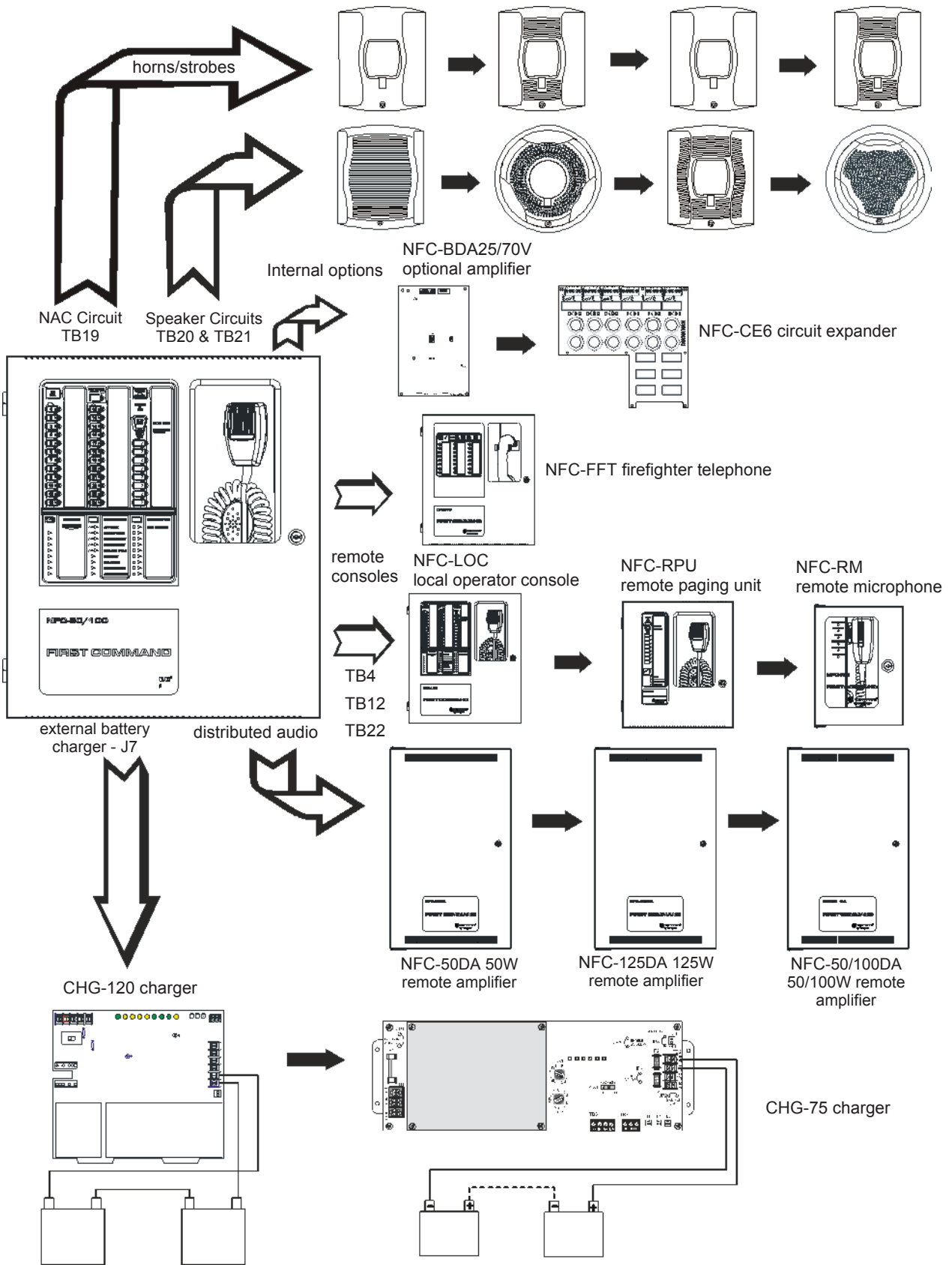

NFC-50/100(E) FirstCommand (Possible Configurations)

NFC-125DA: Distributed (Remote) Audio Amplifier, 125 watts. *Please refer to the data sheet DN-60776 for more information.*

NFC-125DAE: Export version. Distributed (Remote) Audio Amplifier, 125 watts. (240 VAC, 50Hz). *Please refer to the data sheet DN-60776 for more information.*

NFC-50/100DA: Distributed (Remote) Audio Amplifier with back up, 50 watts/100 watts at 25Vrms or 70Vrms. *Please refer to the data sheet DN-60776 for more information.*

NFC-50/100DAE: Export version. Distributed (Remote) Audio Amplifier with back up, 50 watts/100 watts (240 VAC, 50Hz). *Please refer to the data sheet DN-60776 for more information.*

NFC-BDA-BU: Expander card for ECC-50BDA remote amplifier for 100 watt primary / 50 watt back up operation. *Please refer to the data sheet DN-60776 for more information.*

NFC-CE4: Distributed Audio Speaker Circuit/Zone expander module.

NFC-FFT: Fire Fighter Telephone System. *Please refer to the data sheet DN-60779 for more information.*

NFC-RTZM: Remote Telephone Zone Module. *Allows for secure access to the NFC via cell phone or remote telephone means; not UL listed. Please refer to the data sheet DN-60818 for more information.*

N-FPJ: Remote Phone Jack.

FHS-F: Fire Fighters Remote Handset.

FHSC-R: Fire Fighters Handset Cabinet Recessed.

FHSC-S: Fire Fighters Handset Cabinet Surface Mount

TR-CE-B: Optional Trim Ring.

THUMBLTCH: Optional Thumb Latch. (Non UL-Listed).

CHG-75: 25 to 75 ampere-hours (AH) External Battery Charger.

CHG-120: 25-120 ampere-hours (AH) External Battery Charger.

ECC-MICROPHONE: Replacement Microphone only.

BAT-1270: Battery, 12 volt, 7.0 AH (Two required).

BAT-12120: Battery, 12 volt, 12.0 AH (Two required).

BAT-12180: Battery, 12 volt, 18.0 AH (Two required).

BAT-12260: Battery, 12 volt, 26.0 AH (Two required).

BB-26: Battery cabinet mounts up to two 26 AH batteries.

Wiring Requirements

See product manual, part number LS10001-001NF-E for detailed wiring requirements.

Total System Capacity: (NFC-50/100(E) only)

- Total Built-in Audio Power: 50 Watts.
- Total Expandable Audio Power: 100 Watts.
- Total Built-in Speaker Circuits: 2.
- Total Expandable Speaker Circuits: 8.
- Audio Message Max Time Duration: 60 seconds.
- External Audio Input: 1.

Total System Capacity: (Fully Loaded System)

- Total Distributed Audio Power: 1100 Watts.
- Total Speaker Circuits Per System: 24.
- Total Remote Consoles Supported: 8.
- Total Distributed Audio Amplifiers Supported: 8.

Electrical Specifications

PRIMARY (AC) POWER (TB15)

NFC-50/100: 120 VAC, 60 Hz, 3.5 amps.

NFC-50/100E: 240 VAC, 50 Hz, 2.0 amps.

Wire size: minimum #14 AWG (2.00mm²) with 600 V insulation.

SECONDARY POWER (BATTERY) CHARGING CIRCUIT (JT)

- Supports lead-acid batteries only.
- Float charge voltage at 27.3V
- Maximum charge current: 1.0 Amp
- Maximum battery charge capability: 2.8 Amps, 26AH (NFC cabinet holds max. 18AH battery).
- Minimum Battery size: 12 Amp Hour.

AC LOSS RELAY CONTACT RATING (TB3)

- 2.0 amps @ 30 VDC (resistive), 0.5 amps @ 30 VAC (resistive).

FORM C - TROUBLE RELAY CONTACT RATING (TB2)

- 2.0 amps @ 30 VDC (resistive), 0.5 amp @ 30 VAC (resistive).

MNS ACTIVE RELAY CONTACT RATING (TB1)

- 2.0 amps @ 30 VDC (resistive), 0.5 amps @ 30 VAC (resistive).

NOTIFICATION APPLIANCE CIRCUIT (NAC) OUTPUT RATING (TB19)

- One (1) Style Y (Class B) or Style Z (Class A) circuit.
- Power-limited circuitry, (Class 2) supervised.
- Nominal operating voltage: 24 VDC.
- Maximum signaling current for special application power: 2.0A.
- Maximum signaling current for regulated power: 200mA.
- Maximum wiring impedance: 1Ω.
- Current limit: fuse-less, electronic, power-limited.
- End-Of-Line Resistor: 4.7 KΩ, ½ watt, (P/N 71252) required for Style Y (Class B) operation.

Refer to the Device Compatibility Document 15378 for listed compatible devices.

NAC FOLLOWER OUTPUT REMOTE SYNC (TB18)

- Connections for FACP NAC synchronization trigger signal.
- Output terminals: pass-through to other system components.
- Trigger input voltage: 9 to 32 VDC, 24 VDC rated.
- Input current draw in Alarm condition: 10 mA at rated voltage.

SPECIAL APPLICATION POWER (AUX. POWER) (TB17)

- 500 mA @ 24 VDC.
- Used for powering addressable modules and associated End-of-Line power supervision relays.

Power-limited circuitry. Refer to the Device Compatibility Document 15378 for a list of compatible devices.

SPEAKER VOLUME CONTROL OVERRIDE (TB23)

- Style Y (Class B) or Style Z (Class A) circuit.
- Special application power.
- Power-limited circuitry, supervised.
- Nominal operating voltage: 24 VDC.
- Maximum signaling current: 0.25 amps.
- Current limit: fuse-less, electronic, power-limited.
- End-Of-Line Resistor: 4.7 KΩ, ½ watt, (P/N 71252) required for Style Y (Class B) operation.

Speaker Circuits

- Primary Speaker Circuit (TB20)
- Secondary Speaker Circuit (TB21) (with optional amplifier only).
 - Circuit can be wired Style Y (Class B) or Style Z (Class A).
 - Power-limited circuitry.
 - Normal Operating Voltage: 25 VRMS @ 2 amps max and maximum Load Impedance of 12.5Ω (70V @ 700 mA max. with maximum load Impedance of 100Ω operation possible by plugging optional NFC-XRM-70V conversion transformer into J12 of the main control board).
 - Output Power: 50 watts (10 watts when background music is employed).
 - Frequency Range: 400Hz - 4,000Hz.
 - Maximum total capacitance for each speaker circuit: 250 uF.
 - End-of-Line Resistor required for Style Y circuit: 15 KΩ, 1 watt (P/N: ELR-15K).

Command Input Circuits (alarm polarities shown)

CMD1 - TB4 Terminals 3(+) & 4(-) are input terminals and Terminals 1(-) and 2(+) are output terminals which provide feed through of the NAC circuits to NAC devices down stream.

CMD2 - TB5 Terminals 3(+) & 4(-) are input terminals and Terminals 1(-) and 2(+) are output terminals which provide feed through of the NAC circuits to NAC devices downstream.

CMD3 - TB6 Terminals 1(+) & 2(-) are input terminals for contact closure only.

CMD4 - TB6 Terminals 3(+) & 4(-) are input terminals for contact closure only.

CMD5 - TB7 Terminals 1(+) & 2(-) are input terminals for contact closure only.

CMD6 - TB7 Terminals 3(+) & 4(-) are input terminals for contact closure only.

CMD7 - TB8 Terminals 1(+) & 2(-) are input terminals for contact closure only.

CMD8 - TB8 Terminals 3(+) & 4(-) are input terminals for contact closure only.

- Power-limited and supervised circuitry.
- Normal Operating Voltage Range: 10.5 VDC - 29 VDC; (Maximum Voltage: 29 VDC).
- NAC Reverse Polarity Current (requires End-of-Line Resistor from NAC): 1.6 mA maximum.
- Contact Closure Operation Current (requires 4.7KΩ, ½ watt End-of-Line Resistor P/N 27072): 6.6 mA maximum.
- Maximum Wiring Impedance CMD1 - CMD8 (Contact Closure Operation): 200Ω.

NOTE: When the system is programmed for Mass Notification, CMD1 and CMD2 will be programmed for Reverse Polarity only. See manual P/N LS10001-001NF-E for more details.

MAXIMUM INPUT IMPEDANCE:

- CMD1 & CMD2 (Reverse Polarity Operation): 20KΩ.
- CMD1 - CMD8 (Contact Closure Operation): 4.75KΩ.

NIGHT RING INPUT - TB16, TERMINALS 1 (+) & 2 (-)

- Contact closure input.
- Isolated, non-supervised.
- Operation current: 3.8 mA, maximum.
- Maximum wiring impedance: 30KΩ.

- Minimum isolation withstand voltage: 1500 VRMS.

EXTERNAL OPERATOR INTERFACE POWER OUTPUT (TB24)

- Non-resettable power for external operator interface components.
- Power-limited circuitry, non-supervised.
- Nominal operating voltage: 24 VDC.
- Maximum output current: 0.80 amps.
- Current limit: fuse-less, electronic, power-limited circuit.

EXTERNAL DATA BUS (EIA-485) (TB12)

- Data connections for external operator interface components.
- Redundant transceiver circuitry for Class A operability.
- Power-limited circuitry, supervised.
- Maximum wiring impedance: 13.2Ω.

FACP DATA BUS (EIA-485) (TB13)

- Dedicated connection to FACP serial bus.
- Output terminals: pass-through to other system components.
- Isolated, supervised.
- Minimum isolation withstand voltage: 1500 VRMS.
- Maximum wiring impedance: 40Ω (ANN-BUS), 26Ω (ACS-BUS).
- External Audio Riser (TB22).
- Style Y (Class B) or Style Z (Class A) audio connections to external operator interface components.
- Power-limited circuitry, supervised.
- Audio signal level: 3.85 V, maximum.
- Frequency range: 400 Hz - 4 KHz RMS.
- Frequency range (NFC-50/125DA): 800Hz - 2KHz RMS.

EXTERNAL AUDIO INPUT (TB5)

- Input Impedance: 8.5KΩ nominal @1KHz.
- Input Voltage: 700 mV rms maximum.
- Input Current: 0.1 mA maximum @ 700 mV.

NOTE: Some laptops/personal computers only provide an audio output for headphones. It may be necessary to adjust the headphone output level for proper recording of voice messages.

NFC-CE6 Circuit Expander Module Specifications

- Power-limited circuitry.
- Up to six (6) circuits on the NFC-CE6 can be wired as Style Y (Class B) or Style Z (Class A).
- Normal Operating Voltage for Speaker Circuits: 25 V@ 2.0 amps max. (Maximum Load Impedance of 12.5Ω).
- 70.0 V @ 700 mA max. with maximum Load Impedance of 100Ω operation possible for the primary circuit by plugging in an optional NFC-XRM-70V conversion transformer into J12 of the main control board. The same operation is possible for the optional 50W amplifier by selecting the NFC-BDA-70V model.
- Speaker circuit wiring is supervised during standby, background music, and alarm.
- Output Power: 50 watts total; Frequency Range: 400Hz - 4,000Hz.
- Maximum total capacitance: 250 μF. (Note that the total capacitance for the speaker outputs must not exceed the maximum of 250 μF).
- End-of-Line Resistor required for Style Y (Class B) speaker circuit: 15 KΩ, 1 watt (P/N: ELR-15K)TB13 on the main control board: ACS/ANN (EIA-485) electrically isolated link to FACP provides programmed speaker control.

Cabinet Specifications

Backbox: 19.0"(48.26 cm) high x 16.65"(42.29 cm) wide x 5.20"(13.23 cm) deep.

Door: 19.26" (48.92 cm) high x 16.82"(42.73 cm) wide x 0.12"(0.30 cm) deep.

Trim Ring (TR-CE-B): 22.00" (55.88 cm) high x 19.65" (49.91 cm) wide.

Shipping Specifications

Base Unit Weight: 27.85 lbs (12.63 kg).

Temperature and Humidity ranges

This system meets NFPA requirements for operation at 0-49° C/32-120° F and at a relative humidity 93% ± 2% RH (non-condensing) at 32°C ± 2°C (90°F ± 3°F). However, the useful life of the system's standby batteries and the electronic components may be adversely affected by extreme temperature ranges and humidity. Therefore, it is recommended that this system and its peripherals be installed in an environment with a normal room temperature of 15-27° C/60-80° F.

Agency Listings and Approvals

The listings and approvals below apply to the basic NFC-50/100(E) control panel. In some cases, certain modules may not be listed by certain approval agencies or listing may be in process. Consult factory for latest listing status.

- UL/ULC Listed S635.
- Compliant with UFC 4-021-01.
- CSFM: 6911-0028:0265.
- NYC Fire Dept. Certificate of Approval: #6163

Standards and Codes

The NFC-50/100(E) complies with the following UL Standards and with NFPA 72 Fire Alarm system requirements.

- UL 864.
- UL 2572.

Notifier® is a registered trademark of Honeywell International Inc.
©2015 by Honeywell International Inc. All rights reserved. Unauthorized use
of this document is strictly prohibited.



This document is not intended to be used for installation purposes.
We try to keep our product information up-to-date and accurate.
We cannot cover all specific applications or anticipate all requirements.
All specifications are subject to change without notice.

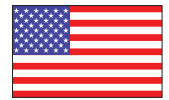

Made in the U.S. A.

For more information, contact Notifier. Phone: (203) 484-7161, FAX: (203) 484-7118.
www.notifier.com

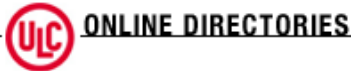

UOXXC.S635 Control Unit Accessories, System, Fire Alarm

[Page Bottom](#)

Control Unit Accessories, System, Fire Alarm

[See General Information for Control Unit Accessories, System, Fire Alarm](#)

NOTIFIER

12 Clintonville Rd
Northford, CT 06472-1610 USA

S635

Amplifier subassembly, Models NFC-BDA-25, NFC-BDA-70V, for use with Emergency Command Center - ACU, Model NFC-50/100.

Backboxes, Models SBB-A4(+), SBB-B4(+), SBB-C4(+), SBB-D4(+).

Backbox Series, CAB-AA4(+++).

Battery boxes, Model(s) BB-17, BB-55, NFS-LBB, NFS-LBBR.

Battery Holder Chassis, Models CHS-M2, CHS-M3, CHS-4N, CHS-BH1.

Circuit Expander subassembly, Model(s) NFC-CE6.

Color Graphic Annunciator (used only as Ancillary Equipment): Model CGAS II-M (c/w 350 mm monitor and mouse), Input: 120 V, 60 Hz, 0.9 A for monitor and 4.5 A for drive. Model CGAS II-T (touch screen type), Input: 120 V, 60 Hz, 1.0 A for monitor and 4.5 A for drive. Model NRT (with IBM 7532 computer), Input: 120 V, 60 Hz, 1.0 A for monitor and 4.5 A for drive. Model V-GAS, Version 3.1 or Model NCS-P3 Pentium III Computer @ 800 MHz with MON-19BLK monitor, Software Version 4.0 or UWS-P4 Pentium IV Computer @ 2 GHz with MON-17 LCD monitor, , Input: 120 V, 60 Hz, 10 A for computer, 0.9 A for monitor (for use only as Ancillary Equipment, not as Primary Annunciator) consists of computer, Model Gateway 2000 4DX2-66; monitor, Model Vivitron 21; and NION interface module; Input: 120 V, 60 Hz, 4.0 A for computer, 2.7 A for monitor, and 24 V dc, 60 mA for NION. Model UNI-NET, Version 4.0, color graphic annunciator/command centre for use as a Primary or Secondary Annunciator. Consists of Pentium 90 or Pentium 200 Intel Computer c/w keyboard, mouse, monitors (Vivitron or Mitsubishi), and NIONS interface modules; Input: 120 V, 60 Hz, 4.0 A for computer, 2.7 A for monitor, and 24 V dc, 60 mA for NIONS. Model UniNet 2000 color graphic annunciator/command centre for use as a Primary or Secondary Annunciator. Consists of wide and local area server, building communication interface 3.3 and NIONS, for use with Notifier and Fire-Lite listed control units; Input: 120 V, 60 Hz, 4.0 A for computer, 2.7 A for monitor, and 24 V dc, 60 mA for NIONS.

Audio Transponder: Model XPIQ, Input: 120 V ac, 60 Hz, 502 mA, Standby, 3.5 A alarm. Output: 25 V ac RMS @ 25 W or 70.7 Vac RMS @ 22 W for use with labelled control unit. Models AFP-300/400, AFC600, NFS-640 and NFS-3030.

Doors, Models DR-A4(+), DR-B4(+), DR-C4(+), DR-D4(+), ADDR-B4(+), ADDR-C4(+), ADDR-D4(+), EQDR-B4(+), EQDR-C4(+), EQDR-D4(+), DR-AA4, DR-AA4R, DR-AA4BR.

Dress Panels, Models DPA-1, DPA-2, BP-4, BP2-4, ADP-4B, DPDW-1B, DPSW-1B, DP-DISP, DPA-1A4, VP-2B, BMP-1, DP-1B, MP-1B, BM-1B.

Dual Monitor Module, Model FDM-1A, 15-32 Vdc, 6.4mA (maximum).

Control Module, Model FTM-1A, 15-32 Vdc, 7.5mA (maximum), FCM-1A, 15-32 Vdc, 6.5 mA (maximum); FRM-1A, 15-32 Vdc, 6.5 mA (maximum), FCM-1, JKM-FCM-1C, JKM-FCM-1 Supply voltage 15-32 Vdc, 6.5 mA maximum, Modules can be installed in the DNR duct housing (1999-05-05), FCM-1C Supply voltage 15-32 V dc, 6.5 mA maximum, Modules can be installed in the DNR and DNRW duct housing.

Enclosures, Models CAB-A4(+), CAB-B4(+), CAB-C4(+), CAB-D4(+), CAB-PS1, DR-PS1, BB-100(+++), BB-200(+++), ABF-1(++), ABF-2(++), ABF-4(+), ABS-1(+), ABS-1T(+), ABS-2(+), ABS-2D(+), ABS-4D(+), ABS-8R(+), CA-1, CA-2, EQBB-B4(+), EQBB-C4(+), EQBB-D4(+), SBB-AA4, SBB-AA4R, SBB-AA4B, BB-UZC, CAB-RP, CAB-RPR.

End-of-Line Resistors: Models ELR-47K, ELR-2.2K, ELR-470, ELR-120, ELR-6.8K, ELR-4.7K, ELR-10K, ELR-1.8K, ELR-27K, ELR-20k, R-10k, R-3.9k, R-47K.

End of line supervision devices, Models REL-2.2K, REL-4.7K, REL-47K.

Emergency Command Center (ACU), Model NFC-50/100, Input 120 V ac, 60 Hz, 3.5 A.

Input/Output Module, Model FDRM-1A, 24 Vdc, 24 mA (2011-09-15).

Input/output relay module, Model JSKM-CMM-9G, 15-32 Vdc, 2 mA.

Lamp Driver Annunciator Module: Models LDM-32, 24 V dc, 56 mA; LDM-E32, 24 V dc, 18 mA; and LDM-R32, 24 V dc, 288 mA.

Liquid Crystal Display Remote Annunciators: Models LCD-80, LCD-80TM and LCD2-80, 24 V dc, 100 mA; complete with ABS-1T and ABF-1 backboxes and AKS-1 key switch. (The ABF-1 may include the AKS-1 key switch).

Liquid Crystal Display Remote Indicators: Models FDU-80C, FDU-80GC, Input: 24 V dc, 56mA.

Local Operator Console, Model NFC-LOC, Input 24 V dc, 85 mA.

Microphone Chassis, Model CMIC-1.

Modem: Model FSK-2400, 24 V dc, 34 mA; and Model TPI-232, 8.25-32 V dc, 65 mA, for use with Notifier's labelled control units.

Monitor Module, Model FMM-1A, JSM-FMM-1C, JSM-FMM-1, 15-32 Vdc, 5.0 mA (maximum); FMM-101A, JSM-FMM-101C, 15-32 Vdc, 600 uA (maximum); FZM-1A, KM-FZM-1C, 15-32 Vdc, 5.1 mA (maximum); Models NMM-100-6A and miniature monitor module Model NMM-100PA, 24 V dc, 230 uA; Model FZM-1A, 15-32 V dc, 5.1 mA (max); Model NDM-100A, 15-24 V dc, 5.2 mA max @ 15 V dc on alarm; fault isolator module, Model N100-ISOA, 24 V dc, 410 uA; control modules Models NC-100A; relay control modules Model NC-100RA, 15-32 V dc, 6.5 mA (max); Multi-Monitor Module, Model NMM-100-10A, Rating: 15-32 V dc, 60 mA per circuit, Multi-Supervised Control Module, Model: NC-100-6A, Input Rating: 15-31 V dc, 35 mA @ Alarm, Output Rating: 18-28 V dc, 3 A, 63 W @ 70.7 V ac per circuit and 22.5W @ 25 V ac per circuit. Multi-Relay (Six) Control Module, Model NC-100R-6A, Rating: 15-32 V dc (Alarm) and Rating for Relay contact: 18-28 V dc, 3 A (max) or 125 V ac @ 0.5A; Six Zone Interface Module, Model NZM-100-6A, Rating: 15-32 V dc, 2 mA (Standby), 40 mA (Alarm).

Multi-Monitor Module: Model: XP10-MA, Rating: 15-32 V dc, 60 mA per circuit.

Multi-Supervised Control Models: Model: XP6-CA, Input Rating: 15-31 V dc, 35 mA @ Alarm, Output Rating: 18-28 V dc, 3A, 63 W @ 70.7 V ac per circuit and 22.5 W @ 25 V ac per circuit.

Multi-Relay (Six) Control Module; Model: XP6-RA, Rating: 15-32 V dc (Alarm) and Rating for Relay contact: 18-28 V dc, 3 A (max) or 125 V ac @ 0.5 A.

Municipal Box Transmitter: Model MBT-1.

Network Control Annunciators: Models NCA, NCA-2, Input: 24 V dc, 483 mA.

Notification Appliance Circuit Extender - Models FCPS-24S6C, FCPS-24S8C, Input: 120 V, 60 Hz, 3.2 A.

Portable Telephone Handset: Model FHS.

Power Supply Field Charger: Model MPS-24, Input: 120 V, 60 Hz, 1.25 A; Model FCPS-24, Input: 120 V, 60 Hz, 2.0 A; Model ACPS-2406, Input: 120 V ac, 50/60 Hz, 3.5 A; ACPS-610, Input 120 Vac, 50/60Hz 5.0A; ACPS-610E, Input 220-240 Vac 50/60 Hz, 2.5A. For use with ULC listed Notifier control units.

Printers: Models PRN-6.

Battery Charger: Model CHG-120, Input: 120 V, 60 Hz, 2.0 A, for use with ULC listed Notifier control units.

Relay Module: Model N-ANN-RLY, Input: 24 V dc, 75 mA; individual relay contacts rated 30 V ac, 0.5 A resistive, 30 V dc, 2 A resistive.

Remote Annunciator: Models ACM-16AT, ACM-16ATG, ACM-16ATY, ACM-24AT, ACM-32A, ACM-32AG, ACM-32AY, ACM-48A, ACM-16ATCS4, ACM-16ATCS, ACM-32ACSS, Input: 24 V dc, 56 mA; Models AEM-16AT, AEM-16ATG, AEM-16ATY, AEM-24AT, AEM-32A, AEM-32G, AEM-32Y, AEM-48A, Input: 24 V dc, 18 mA; Model NCA, Input : 24 V dc, 483 mA. Model N-ANN-LED, Input: 18-28 V dc, 60 mA.

Model N-ANN-I/O, Input: 24VDC, 200mA†(f01).

Remote Indicator - Model N-ANN-80C, Input 24 V dc, 40 mA.

Remote Modules: Monitor module, Model MMX-1A, 24 V dc, 230 mA; control module, Models CMX-1 and CMX-2A, 24 V dc, 1.0 A; and fault isolator module, Model ISO-X, 24 V dc, 410 uA. Model MMX-2, 16-28 V dc, 90 mA per device, 7.5 mA for comm. line with latched LED. Miniature monitor module, Model MMX-101A, 24 V dc, 230 uA; Releasing Control module, Model FCM-1-RELA, 24V dc, 2A.

Remote Monitor: Model CRT-2, Input: 120 V, 60 Hz, 0.5 A.

Remote Printer: Model PRN-4, Input: 120 V, 60 Hz, 0.5 A; Model PRN-5, Input: 120 V 50/60 Hz, 1.0 A, for use with Notifier's listed fire alarm control units.

Remote Telephone: Model FHE.

Remote Telephone Jack: Model FPJ.

Repeaters for Network: Models RPT-F, RPT-W and RPT-WF; 18-26.4 V, 19 mA for use with NOTI-FIRE-NET network system only.

Repeaters for Annunciators: Model RPT-485W, 18-28 V dc, 47 mA (maximum); Model RPT-485WF, 18-28 V dc, 49 mA (maximum).

Serial/parallel interface, Model N-ANN-S/PG, Input: 24VDC, 50mA†.

Smoke Control System: Control station, Model SCS-8, 24 V dc, 62 mA; control station expander, Model SCE-8, 24 V dc, 34 mA; control lamp driver, Model SCS-8L, 24 V dc, 62 mA; and lamp driver expander, Model SCE-8L, 24 V dc, 34 mA; for use with labelled control units, Models NFS-3030 and NFS-3030E.

Audio Transformer subassembly, Model(s) NFC-XRM-70V (a, b).

Universal Digital Alarm Communicator Transmitter: Model UDACT, 24 V dc, 100 mA, for use with Notifier's labelled control units, Models S5000, S500, AFP-200, NFS-3030 and NFS-3030E.

Six Zone Interface Module: Model XP6-MAA, Rating: 15-32 V dc, 2 mA (Standby), 40 mA (Alarm).

† Complementary Listed under FSYE, QVAX, UOXX.

(f01) - Intended for use with specific control units as indicated in control unit installation manual.

(+) - May include /R, /F or /B suffix.

(++) - May include /R, /F, /B or /D suffix.

(+++)- The CAB-AA4 Backox Series is made up of the SBB-AA4, SBB-AA4R, SBB-AA4B, SBB-AA4BR enclosures, and the DR-AA4, DR-AA4B, DR-AA4R, DR-AA4BR Doors.

(++++)- May include /R suffix.

Last Updated on 2014-10-01

Copyright © 2015 Underwriters Laboratories of Canada Inc.

When the UL Leaf Mark is on the product, or when the word "Environment" is included in the UL Mark, please search the [UL Environment database](#) for additional information regarding this product's certification.

The appearance of a company's name or product in this database does not in itself assure that products so identified have been manufactured under ULC's Follow-Up Service. Only those products bearing the ULC Mark should be considered to be Listed and covered under ULC's Follow-Up Service. Always look for the Mark on the product.

ULC permits the reproduction of the material contained in the ULC Online Directories subject to the following conditions: 1. The Guide Information, Designs and/or Listings (files) must be presented in their entirety and in a non-misleading manner, without any manipulation of the data (or drawings). 2. The statement "Reprinted from the ULC Online Directories with permission from Underwriters Laboratories of Canada Inc." must appear adjacent to the extracted material. In addition, the reprinted material must include a copyright notice in the following format: "Copyright © 2015 Underwriters Laboratories of Canada Inc."

An independent organization working for a safer world with integrity, precision and knowledge.



NOT-BG12LX

Addressable Manual Pull Station For FireWarden Series Panels



Intelligent/Addressable Devices

General

The Notifier NOT-BG12LX is a state-of-the-art, dual-action (i.e., requires two motions to activate the station) pull station that includes an addressable interface for FireWarden series intelligent control panels, and the NSP-25 panel. Because the NOT-BG12LX is addressable, the control panel can display the exact location of the activated manual station. This leads fire personnel quickly to the location of the alarm.

Features

- Maintenance personnel can open station for inspection and address setting without causing an alarm condition.
- Built-in bicolor LED, which is visible through the handle of the station, flashes in normal operation and latches steady red when in alarm.
- Handle latches in down position and the word “ACTIVATED” appears to clearly indicate the station has been operated.
- Captive screw terminals wire-ready for easy connection to SLC loop (accepts up to 12 AWG/3.25 mm² wire).
- Can be surface mounted (with SB-10 or SB-I/O) or semi-flush mounted. Semi-flush mount to a standard single-gang, double-gang, or 4" (10.16 cm) square electrical box.
- Smooth dual-action design.
- Meets ADAAG controls and operating mechanisms guidelines (Section 4.1.3[13]); meets ADA requirement for 5 lb. maximum activation force.
- Highly visible.
- Attractive shape and textured finish.
- Key reset.
- Includes Braille text on station handle.
- Optional trim ring (BG12TR).
- Meets UL 38, Standard for Manually Actuated Signaling Boxes.

Construction

Shell, door, and handle are molded of durable polycarbonate material with a textured finish.

Specifications

- **Shipping Weight:** 9.6 oz. (272.15 g)
- **Normal operating voltage:** 24 VDC.
- **Maximum SLC loop voltage:** 28.0 VDC.
- **Maximum SLC loop current:** μ A.
- **Temperature Range:** 32°F to 120°F (0°C to 49°C)
- **Relative Humidity:** 10% to 93% (noncondensing)
- **For use indoors in a dry location**

Installation

The NOT-BG12LX will mount semi-flush into a single-gang, double-gang, or standard 4" (10.16 cm) square electrical outlet box, or will surface mount to the model SB-10 or SB-I/O surface backbox. If the NOT-BG12LX is being semi-flush mounted, then the optional trim ring (BG12TR) may be used.



The NOT-BG12LX
Addressable Manual Pull Station

The BG12TR is usually needed for semi-flush mounting with 4" (10.16 cm) or double-gang boxes (not with single-gang boxes).

Operation

Pushing in, then pulling down on the handle causes it to latch in the down/activated position. Once latched, the word “ACTIVATED” (in bright yellow) appears at the top of the handle, while a portion of the handle protrudes from the bottom of the station. To reset the station, simply unlock the station with the key and pull the door open. This action resets the handle; closing the door automatically resets the switch.

Each manual station, on command from the control panel, sends data to the panel representing the state of the manual switch. Two rotary decimal switches allow address settings (1 – 99 on NFW2-100/NFW2-100C, 1 – 50 for NFW-50/NFW-50C).

Architectural/Engineering Specifications

Manual Fire Alarm Stations shall be non-coded, with a key-operated reset lock in order that they may be tested, and so designed that after actual Emergency Operation, they cannot be restored to normal except by use of a key. An operated station shall automatically condition itself so as to be visually detected as activated. Manual stations shall be constructed of red-colored polycarbonate material with clearly visible operating instructions provided on the cover. The word FIRE shall appear on the front of the stations in white letters, 1.00 inches (2.54 cm) or larger. Stations shall be suitable for surface mounting on matching backbox SB-10 or SB-I/O; or semi-flush mounting on a standard single-gang, double-gang, or 4" (10.16 cm) square electrical box, and shall be installed within

the limits defined by the Americans with Disabilities Act (ADA) or per national/local requirements. Manual Stations shall be Underwriters Laboratories listed.

Manual stations shall connect with two wires to one of the control panel SLC loops. The manual station shall, on command from the control panel, send data to the panel representing the state of the manual switch. Manual stations shall provide address setting by use of rotary decimal switches.

Product Line Information

NOT-BG12LX: Dual-action addressable pull station. Includes key locking feature.

NOT-BG12LXA: *Canadian* Dual-action addressable pull station. Includes key locking feature.

SB-10: Surface backbox; metal.

SB-I/O: Surface backbox; plastic.

BG12TR: Optional trim ring.

17021: Keys, set of two.

Agency Listings and Approvals

In some cases, certain modules or applications may not be listed by certain approval agencies, or listing may be in process. Consult factory for latest listing status.

- **UL Listed:** S692 (listed for Canadian and non-Canadian applications)
- **MEA:** 67-02-E Vol. IV
- **CSFM:** 7150-0028:0199
- **FDNY:**
- **FM Approved**

Patented: U.S. Patent No. D428,351; 6,380,846; 6,314,772; 6,632,108.



Notifier® is a registered trademark of Honeywell International Inc.
©2010 by Honeywell International Inc. All rights reserved. Unauthorized use of this document is strictly prohibited.



This document is not intended to be used for installation purposes.
We try to keep our product information up-to-date and accurate.
We cannot cover all specific applications or anticipate all requirements.
All specifications are subject to change without notice.



Made in the U.S. A.

For more information, contact Notifier. Phone: (203) 484-7161, FAX: (203) 484-7118.
www.notifier.com

UNIUS692
Boxes, Non-coded

[Page Bottom](#)

Boxes, Non-coded

[See General Information for Boxes, Non-coded](#)

NOTIFIER

S692

12 CLINTONVILLE RD
NORTHFORD, CT 06472 USA

Models BG-1, -1-2W, BNG-1(X), -1F, -1FTS, -1TS, -1SP, BRG-1, -1FTS, -1TS; Models NBG-10, -10A, -10L, -10P, -10T, -10WP; Models NAR-10, NARA-10, NBG-10SP; Model LNG-1.

Back boxes, Models SB-10, SB-I/O, 58BB.

Models NBG-12, -12L, -12LA, -12LPS, -12LPSP, -12LR, -12LRA, -12LSP, -12LW, -12LWP, -12LX, -12LXBL, -12LXP, -12LXSP, -12NC, -12PS, -12S, -12SP, -12W, -12WP, NOT-BG12LX; Models NBG-12LAOB, -12LAO, -12LO, -12LOB, -12LW, -12LWP, -12W, -12WP are for outdoor use when used with a back box as specified in the installation instructions.

(X) Denotes color of box.

[Last Updated](#) on 2009-05-12

[Questions?](#)

[Notice of Disclaimer](#)

[Page Top](#)

[Copyright © 2009 Underwriters Laboratories Inc.®](#)

The appearance of a company's name or product in this database does not in itself assure that products so identified have been manufactured under UL's Follow-Up Service. Only those products bearing the UL Mark should be considered to be Listed and covered under UL's Follow-Up Service. Always look for the Mark on the product.

UL permits the reproduction of the material contained in the Online Certification Directory subject to the following conditions:
1. The Guide Information, Designs and/or Listings (files) must be presented in their entirety and in a non-misleading manner, without any manipulation of the data (or drawings). 2. The statement "Reprinted from the Online Certifications Directory with permission from Underwriters Laboratories Inc." must appear adjacent to the extracted material. In addition, the reprinted material must include a copyright notice in the following format: "Copyright © 2009 Underwriters Laboratories Inc.®"

DNR-InnovairFlex

Intelligent Non-Relay Photoelectric Duct Smoke Detector



Intelligent Devices

General

The Notifier InnovairFlex DNR intelligent non-relay photoelectric duct smoke detector and DNRW watertight non-relay photoelectric duct smoke detector feature a pivoting housing that fits both square and rectangular footprints capable of mounting to a round or rectangular duct.

DNRW duct smoke detector, with its NEMA-4 rating, is listed as a watertight, UV resistant enclosure providing protection against falling dirt, rain, and windblown dust, splashing and hose directed water, allowing operators to use the detector in the most extreme environments.

These units sense smoke in the most challenging conditions, operating in airflow speeds of 100 to 4,000 feet per minute, temperatures of -4 degrees F to 158 degrees F, and a humidity range of 0 to 95 percent (non-condensing.)

An improved cover design isolates the sensor head, which allows for ease of maintenance. A cover tamper feature indicates a trouble signal for a removed or improperly installed sensor cover. The Notifier InnovairFlex housing provides a 3/4-inch conduit knockout and ample space to facilitate easy wiring and mounting of a relay module.

The Notifier InnovairFlex duct smoke detector can be customized to meet local codes and specifications without additional wiring. The new InnovairFlex product line is compatible with all previous Innovair models, including remote test accessories.

Features

- Photoelectric, integrated low-flow technology
- Air velocity rating from 100 ft/min to 4,000 ft/min (0.5 m/s to 20.32 m/s)
- Versatile mounting options: square or rectangular configuration
- Broad ranges for operating temperature (-4F to 158F) and humidity (0% to 95% non-condensing)
- Patented sampling tube installs from front or back of the detector with no tools required
- Cover tamper signal
- Increased wiring space with a newly added 3/4" conduit knockout
- Available space within housing to accommodate mounting of a relay module
- Easily accessible code wheels on sensor head (sold separately)
- Clear cover for convenient visual inspection
- Remote testing capability
- Requires com line power only
- Accommodates the installation of an addressable relay module, sold separately, (FRM-1 or NC-100R) for applications requiring a Form-C relay.

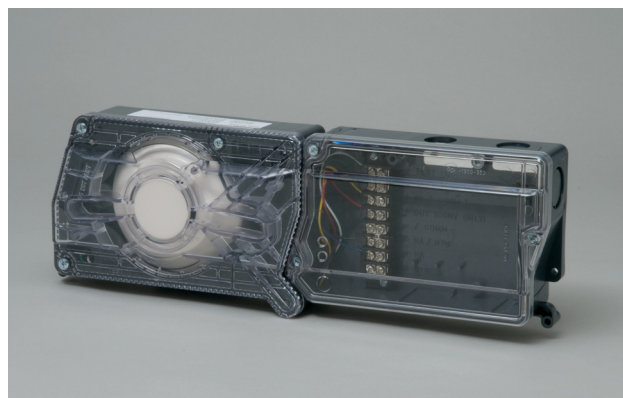

Specifications

Size: (Rectangle) 14.38 in (37 cm) Length; 5 in (12.7 cm) Width, 2.5 in (6.6 cm) Depth

Size: (Square) 7.75 in (19.7 cm) Length; 9 in (22.9 cm) Width; 2.5 in (6.35 cm) Depth

Weight: 1.6 lb (0.73 kg)

Operating Temperature Range: -4 degrees F to 158 degrees F (-20 degrees C to 70 degrees C)

Storage Temperature Range: -22 degrees F to 158 degrees F (-30 degrees C to 70 degrees C)

Operating Humidity Range: 0% to 95% relative humidity (non-condensing)

Air Duct Velocity: 100 to 4,000 ft/min (0.5 to 20.32 m/s)

Accessories

Notifier provides system flexibility with a variety of accessories, including two remote test stations and different means of visible and audible system annunciation. As with our duct smoke detectors, all duct smoke detector accessories are UL listed.

DNR(W)s with a date code of 0013 or higher do not require external 24VDC for remote test applications when used with a remote-test-capable detector.

ACCESSORY CURRENT LOADS AT 24 VDC

Device	Standby	Alarm
RA100Z	0mA	12 mA Max
RTS151/ RTS151KEY	0mA	12mA Max

Agency Listings and Approvals

Consult product manual for lists of compatible UL-Listed devices. In some cases, certain modules may not be listed by certain approval agencies, or listing may be in process. Consult factory for latest listing status.

- **UL:** S911, S635
- **ULC:** S911, S635
- **CFSM:** 3242-0075:0221

Product Line Information

NOTE: "A" or "CDN" suffix indicates ULC listed model.

DNR(A): Intelligent non-relay photoelectric low flow smoke detector housing. Requires photoelectric smoke detector (sold separately).

DNRW: Watertight intelligent non-relay photoelectric low flow duct smoke detector housing. Requires photoelectric smoke detector (sold separately). NEMA-4.

FSP-851R: Remote test capable addressable low-profile photoelectric smoke detector.

FSP-851: Addressable low-profile photoelectric smoke detector.

NP-100: Addressable low-profile photoelectric smoke detector for FireWarden series panels.

NP-100R: Remote test capable addressable low-profile photoelectric smoke detector for FireWarden series panels.

DCOIL: Remote test coil. Required for older DNR(W) duct detector housing.

DST1(A): Metal sampling tube duct width up to 1 ft (0.3m)

DST1.5(A): Metal sampling tube duct widths up to 1 ft to 2 ft (0.3 to 0.6 m)

DST3(A): Metal sampling tube duct widths up to 2 ft to 4 ft (0.6 to 1.2 m)

DST5(A): Metal sampling tube duct widths up to 4 ft to 8 ft (1.2 to 2.4 m)

DST10(A): Metal sampling tube duct widths up to 8 ft to 12 ft (2.4 to 3.7 m)

DH400OE-1: Weatherproof enclosure

ETX: Metal exhaust tube duct, width 1 ft (0.3 m)

M02-04-00: Test magnet

P48-21-00: End cap for metal sampling tubes

RA100Z(A): Remote annunciator alarm LED

RTS151(A): Remote test station

RTS151KEY(A): Remote test station with key lock

Important Note

- DNRW duct detector housings with a date code of 0013 or higher do not require a DCOIL or auxiliary 24 VDC for remote test applications when used with a remote test capable detector.
- DNRW duct detector housings with a date code of 0012 or earlier require a DCOIL and auxiliary 24 VDC power for remote test applications.

ONYX® and NOTIFIER® are registered trademarks and NOTI•FIRE•NET™ is a trademark of Honeywell International Inc. ©2011 by Honeywell International Inc. All rights reserved. Unauthorized use of this document is strictly prohibited.



This document is not intended to be used for installation purposes.
We try to keep our product information up-to-date and accurate.
We cannot cover all specific applications or anticipate all requirements.
All specifications are subject to change without notice.



Made in the U.S. A.

For more information, contact Notifier. Phone: (203) 484-7161, FAX: (203) 484-7118.
www.notifier.com



UROX.S911 Smoke-automatic Fire Detectors

[Page Bottom](#)

Smoke-automatic Fire Detectors

[See General Information for Smoke-automatic Fire Detectors](#)

SYSTEM SENSOR UNINCORPORATED, DIV OF HONEYWELL INTERNATIONAL INC

S911

3825 OHIO AVE

ST CHARLES, IL 60174 USA

Detector			Compatibility	Velocity Range (fpm)	
Model	Application	Type		Restrictions	Min
1112/24 (d), 1112/24B (d)	OAP	I	D4	0	1200
1151, 1151EIS	OAP, D(I), RS	I	D2	0	500
1251	OAP	I	D4	0	500
1251B (d)	OAP	I	*1, *2	0	1200
1400	OAP	I	D2	0	1200
1412B, 1424	OAP, RS	I	D4	0	1200
1451	OAP, D(I), RS	I	D2	0	1200
1451DH	OAP, D(I)	I	D2	0	1200
1451DHHT (e)	OAP, D(I)	I	D2	0	1200
2100RFADT	OAP	P(RF)(IHD)	D2	0	300
2100S	OAP	P	D2	0	3000
2112ATL (a)	OAP	P(IHD)	D4	0	3000
2112i3 (a)	OAP	P(IHD)	D2	0	1000
2151 (d)	OAP	P	D2	0	3000
2151T	OAP	P(IHD)	D2	0	3000
2251	OAP, D(I)	P	D2	0	4000
2251-COPTIR	OAP	P(IHD)	D4	0	4000
2251B,2251BR (d)	OAP, D(I)	P	*1, *2	0	4000
2251T	OAP, D(I)	P(IHD)	D2	0	4000
2251TB	OAP, D(I)	P(IHD)	*1, *2	0	4000
2251TBC	OAP, D(I)	P(IHD)	*1, *2	0	4000
2251TM	OAP	P(IHD)	D2	0	4000
2251TMB	OAP, D(I)	P(IHD)	*1, *2	0	4000
2251TMBC	OAP, D(I)	P(IHD)	*1, *2	0	4000
2400	OAP	P	D2	0	3000
2400TH, 2551T (d)	OAP	P(IHD)	D2	0	3000
2412	OAP, RS	P	D2	0	3000

2412TH	OAP, RS	P(IHD)	D2	0	3000
2424, 2424TH	OAP, RS	P(IHD)	D2	0	3000
2424AT (a), 2424AIT (a)(f)	OAP	P(IHD)	D4	0	3000
2451 (c)	OAP, D(I)	P	D2	0	3000
2451TH	OAP, RS	P(IHD)	D2	0	3000
2551 (d), 2551HR (d)	OAP, D(I)	P	D2	0	3000
2551T	OAP, D(I)	P(IHD)	D2	0	3000
2551TH	OAP, D(I)	P(IHD)	D2	0	3000
2D51 (e)(g)	OAP, D(I)	P	D2	0	4000
2W-B, 4W-B, 2400E, 2412/24E, JTY-GD-2412/24E					
	OAP	P	D2	0	1000
2WT-B, 4WT-B	OAP	P(IHD)	D2	0	1000
2WTA-B (a), 2WTR-B (a)	OAP, RS	P(IHD)	D2	0	1000
3251	OAP, D(I)	P/I	D2	0	1000
4WITAR-B (a), 4WTAR-B (a), 4WTR-B, 4WTA-B (a)					
	OAP, RS	P(IHD)	D2	0	1000
5192SD	OAP	P	D4	0	4000
5193SD	OAP	P	*4	0	1000
5193SDT	OAP	P(IHD)	*4	0	1000
5806W3 (a)	OAP	P(RF)	D2	0	300
5808LST	OAP	P(RF)(IHD)	D2	0	300
5808W3 (a), W3-ADT (a)	OAP	P(RF)(IHD)	D2	0	300
7251 (p)	OAP	Laser	D2		
881 (b)	OAP	I	D2	0	300
882 (b)	OAP	P	D2	0	300
BEAM1224, BEAM1224S	OAP	PB	D2		
BEAM200, BEAM200S	OAP	PB	D2		
CP350	OAP	I	D2	0	300
CP355	OAP	I	D2	0	1200
CPX-751 (h)	OAP, D(I)	I	D2	0	4000
ED-II (d)	OAP	I	*3	0	1200
ED-PI (d), ED-P (d), ED-DP (d), ED-DPI (d)					
	OAP, D(I)	P	*3	0	4000
ED-PTI, ED-PT	OAP, D(I)	P(IHD)	*3	0	4000
FTX-P1 Filtrex	OAP	P	D2	0	4000
HFS-P		P	None		
HFS-PT		P	None		
SD300	OAP	P	D2	0	3000
SD300T	OAP	P(IHD)	D2	0	3000
XL4760SDT, 5192SDT	OAP	P(IHD)	D4	0	4000

Detector

Compatibility

Velocity Range (fpm)

Pressure Differential Between Sampling Tube

Model	Application	Type	Restrictions	Min	Max	Min	Max
DH500ACDC (w. 2551 head) (d)	D(ST)	P	D2	500	4000	0.05	1
7251DH	D(ST)	Laser	D2			0.01	1.2
7251DH (w. 7251 head)	D(ST)	Laser	D2	300	4000	0.01	1.2
D2 (w. 2151 head) (e)	D(ST)	P	D2	100	4000	0.01	1.11
D4120 (w. 2D51 head) (e), D4240 (w. 2D51 head) (e), P270-3000PL (w. 2D51 head) (e), TD41203 (w. 2D51 head) (e), TD41204 (w. 2D51 head) (e), LD4120X (w. 2D51 head) (e), LD4120H (w. 2D51 head) (e), TD4C (w. 2D51 head) (e), D4S (w. 2D51 head) (e), PD4120 (w. 2D51 head) (e), YD4120 and YD4 (w. 2D51 head) (e)							
	D(ST)	P	D2	100	4000	0.01	1.11
D4120W (w. 2D51 head) (e) (m)	D(ST)	P	D2	100	4000	0.01	1.11
DH100ACDCI (d)	D(ST)	I	D4	500	4000	0.01	1.2
DH100ACDCP (w. 1451DH head)	D(ST)	I	D2	500	4000	0.01	1.2
DH100ACDCP (w. 2451 head)	D(ST)	P	D2	500	4000	0.01	1.2
DH200P(k), EDH200P(k), DH200RP(k)	D(ST)	P	D2	500	4000	0.01	1.2
DH400 Series (w. 2151 head) (d)	D(ST)	P	D2	500	4000	0.01	1.2
DH400 Series (w. 1451DH head) (d)	D(ST)	I	None	500	4000	0.01	1.2
DH400 Series (w. 2451 head) (d)	D(ST)	P	D2	500	4000	0.01	1.2
DH400ACDCIHT (w. 1451DHHT head) (e)	D(ST)	I	D4	500	4000	0.01	1.2
DH500 (w. 1551 head) (d)	D(ST)	I	D2	500	4000	0.01	1.2
DH500 (w. 2551 head) (d)	D(ST)	P	D2	500	4000	0.01	1.2
DH500ACDC (w. 1551 head) (d)	D(ST)	I	D2	500	4000	0.01	1.2
DH500ACDC (w. 7251 head) (d)	D(ST)	Laser	D2			0.01	1.2
DNR (e) (i), DNRW (e) (m) (i)	D(ST)	P	D2	100	4000	0.01	1.11
DNRECL (e) (r)	D(ST)	P	D2	100	4000	0.01	1.11
DNRHS	D(ST)	Laser	D2	300	4000	0.01	1.11
ED-DPR (ED-DPI, ED-P)	D(ST)	P	*3	500	4000	0.01	1.2
LD4120H (w.2D51/A head) (e)	D(ST)	P	D2	100	4000	0.01	1.11
LD4120X (w.2D51/A head) (e)	D(ST)	P	D2	100	4000	0.01	1.11
LD4P120H (w.2D51/A head) (e)	D(ST)	P	D2	100	4000	0.01	1.11
LD4P120X (w.2D51/A head) (e)	D(ST)	P	D2	100	4000	0.01	1.11
LD4S (w. 2D51/A head) (e)	D(ST)	P	D2	100	4000	0.01	1.11
RD4120 (w. 2D51 head) (e)	D(ST)	P	D2	100	4000	0.01	1.11
D350P, D350RP	D(ST)	P	D2	500	4000	0.0015	1.2
D350PL, D350RPL	D(ST)	P	D2	100	4000	0.0015	1
DH100ACDCLP, DH100ACDCLPX, DH100ACDCBPY, EDH100LP470, EDH100LP1000							
	D(ST)	P	D4	100	4000	0.0015	1.2
DH100ACDCLWP (m) (o)	D(ST)	P	D4	100	4000	0.0015	1.2

DH100LP	D(ST)	P	D2	100	4000	0.0015	1.2
DH200PL	D(ST)	P	D2	100	4000	0.0015	1.2
DH200RPL	D(ST)	P	D2	100	4000	0.0015	1.2
DH400ACDCIR, DH400ACDCP, DH400ACDCPX							
	D(ST)	P	D4	100	4000	0.0015	1.2
EDH100ACDCLP, EDH200RP (k)	D(ST)	P	D4	100	4000	0.0015	1.2
EDH100LP	D(ST)	P	D2	100	4000	0.0015	1.2
SD350, SD355, SD350T, SD355T, AD355	D(ST)	P	D2	100	4000	0.0015	1.2

Base Model	Related Detector	Control Unit Compatibility Restrictions
B114LPBT(RS)	1151, 2151	B2
B200S (d)(q), B200SR (d)(q)	2251B, 2251TB, 2251TBC, 2251TMB, 2251TMBC, 7251, 1251B, 5251B, 5251BC, 5251H, 5251RB, 2251-COPTIR, FSP-851, FSP-851T, FSP-851TC, FAPT-851, FAPT-851C, FSL-751, FSI-851, FST-851, FST-851C, FST-851H, FST-851R, FSC-851, LPX-751L, SD355SD355T, AD355, CP355, H355H355H355R, ASD-PL2F, ASD-PTL2F, MCS-ACCLIMATE2F, ASD-LS, ASD-IL2F, ATD-L2F, ATD-HL2F, ATD-RL2F, 2951J, 2951TJ, 2951TMJ, 7351J, 1951J, 5951J, 5951HJ, 5951RJ, 2951J-COPTIR, 2951ADT, 2951TADT, 951TMADT, L2351ADT, 1951ADT, 5951ADT, 5951HADT, 5951RADT, 2251FB, 2251TFB, 1251FB, 5251FB, MIX-2251B, MIX-2251TB, MIX-2251TMB, MIX-1251B, MIX-5251B, MIX-5251H, MIX-5251RB, MIX-2251DOD, MIX-1251DOD, MIX-5251DOD, MRI-2251B, MRI-2251TB, MRI-2251TMB, MRI-1251B, MRI-5251B, MRI-5251H, MRI-5251RB, IDP-PHOTO, IDP-PHOTO-T, IDP-ACCLIMATE, IDP-ION, IDP-HEAT, IDP-HEAT-HT, IDP-HEAT-ROR, SK-PHOTO, SK-PHOTO-T, SK-ACCLIMATE, SK-ION, SK-HEAT, SK-HEAT-HT, SK-HEAT-ROR, NP-100, NP-100T, NP-A100, NI-100, NH-100, NH-100H, NH-100R, TC806B1076, TC806B1084, TC840M1021, TC846A1013, TC846A1005, TC807B1059, TC808B1041, TC808B1066, TC808B1058, TC840C1000	B4
B350LP	SD355, SD355T, CP355, H355, H355T, H355R, AD355	B4
B401, B110LP, B110RLP, B112LP(RS), B114LP(RS), (BT), B116LP(RS), B401BH, B401B, B401LP, B401R, B402B(RS), B404B(RS), B404BT, B406B(RS), B401BH-2, B401BR		
	1151, 1151EIS, 2151, 2151T, 1451, 2451, JTY-GD-2451, 2451TH, 5451	B2
B501 (Rated:0-66C), B501B (Rated:0-66C), B501BH, B501BHT, B501BH-2, B501BHT-2, B210LP (Rated:0-66C), B224BI, B224RB		
	FSC-851, FSP-851, FSP-851R, FSP-851T, FSP-851TC, FSI-851, FST-851, FST-851H, FST-851R, FAPT-851, FAPT-851C, FSL-751, LPX-751L, SD355, SD355T, CP355, H355, H355T, H355R, AD355, ASD-PL2F, ASD-PTL2F, ASD-IL2F, ATD-L2F, ATD-HL2F, ATD-RL2F, MCS-ACCLIMATE2F, ASD-LS, 2951ADT, 2951TADT, 1951ADT, 5951ADT, 5951HADT, 5951RADT, 2951MADT, NP-100, NP-100T, NI-100, NP-A100, NH-100, NH-100R, NH-100H, 2951J-COPTIR, 2951J, 2951TJ, 1951J, 5951J, 5951HJ, 5951RJ, 2951TMJ, 7351J, 2251FB, 2251TFB, 1251FB, 5251FB, 2251B, 2251TB, 2251TBC, 1251B, 5251B, 5251BC, 5251H, 5251RB, 2251TMB, 2251TMBC, 7251, IDP-PHOTO, IDP-PHOTO-T, IDP-ION, IDP-HEAT, IDP-HEAT-HT, IDP-HEAT-ROR, TC840C1000, TC806B1076, TC806B1084, TC807B1059, TC808B1041, TC808B1066, TC808B1058, TC840M1021, TC846A1005, TC846A1013, 2D51 (e)(g)	B4
B501B-FTX	FTX-P1 Filtrex	B2
B710LP	FSC-851, FSP-851, FSP-851T, FSP-851TC, FSI-851, FAPT-851, FAPT-851C, FST-851, FST-851C, FST-851H, FST-851R, 2951ADT, 2951TADT, 1951ADT, 5951ADT, 5951HADT, 5951RADT, 2951TMADT, NP-100, NP-100T, NI-100, NP-A100, NH-100, NH-100R, NH-100H	B4
B801	881, 882	B2
B801RA	882	B2
EBR (d), EBF (d), EB (d), EBFI (d), EBI (d)		
	ED-PTI, ED-PT, ED-PI, ED-P, ED-II	B2
EBS (d)	ED-PTI, ED-PT, ED-PI, ED-P, ED-II	B2
RMK400 (n), SMB 600 (n)	1251, 1451, 2151, 2151T, 2251, 2251B, 2251TB, 2251TBC, 2251TMB, 2251TMBC, JTY-GD-2451, 2451 (Heat Detectors)	None

B2 - For connection to Listed control units with which compatibility was determined by test or a review of circuit parameters. Interconnection and compatible models indicated on installation wiring diagram for detector (base) and/or control unit.

B4 - For connection to any manufacturer's Listed compatible control unit.

D2 - For connection to Listed control units with which compatibility was determined by test or a review of circuit parameters. Interconnection and compatible models indicated on installation wiring diagram for detector (base) and/or control unit.

D4 - For connection to any manufacturer's Listed compatible control unit.

*1 - For connection to Listed Control Unit, Model ZXa manufactured by Morely with which compatibility was determined by test or a review of circuit parameters. Interconnection and compatible models are indicated on installation wiring diagram for Detectors and/or control units.

*2 - For connection to Listed Control Unit, Shark Series 10 056 manufactured by Fike Protection with which compatibility was determined by test or a review of circuit parameters. Interconnection and compatible models are indicated on installation wiring diagram for Detectors and/or control units.

*3 - For connection to Listed Fike model Cybercat fire alarm control panel.

*4 - For connection to Listed fire alarm control panel, models Vista-32FB, Vista-40, Vista-50, Vista-50P, Vista-100, Vista-128B, Vista 128BP, Vista128BPADT, Vista-128FB, Vista-128FBP, Vista-250BP, Vista-250FBP, FA1220C, FA1220CV, FA1340C, FA1600C, FA1660C, FA1700C, Focus 200 Plus and Focus Cadet, manufactured by Honeywell Security.

OAP - Open Area Protection

I - Ionization

D(I) - Duct Detector - Installation Inside Duct

RS - Releasing Service

P - Photoelectric

RF - Includes Integral Radio Frequency Transmitter

IHD - Includes Integral Heat Detector

P/I - Combination Photoelectric and Ionization

PB - Projected Beam

D(S1) - Duct Detector - Sampling Tubes

(a) - Includes integral audible signal.

(b) - Model is not to be sold or distributed in the United States of America.

(c) - Suitable for duct application, installation inside duct, only when used with Model B404B, B404BT or B114LP base and Model RTC remote test kit.

(d) - Suitable for use in ambient temperatures of 0-49 C (32-120 F).

(e) - Suitable for elevated temperatures up to 70 C.

(f) - Heat sensor is electrically isolated.

(g) - Model 2D51 smoke detector for use in duct smoke detectors Models D4120, D4120W, P270-3000PL, TD41203, TD41204, LD4120X, LD4120H, TD4C, and duct smoke detector sub assembly Model D4S only.

(h) - For OAP air deflector velocity is from 0-500 fpm: for D(I) is from 0-4000.

(i) - DNR and DNRW duct housing can be used with the following compatible detector heads: FSP-851, SD355, ASD-PL2F, 2951ADT, NP-100, 2951J, 2251FB, 2251B, IDP-PHOTO, TC806B1076, MIX-2251B, and MRI-2251B.

(k) - Suitable for use in ambient temperatures of 0-55 C (23-131 F).

(m) - Models D4120W and DNRW use a Type 4 enclosure waterproof.

(n) - Recessed mounting base RMK400 is only to be used with bases B401, B501, and detector Models 1251, 1451, 2151, 2151T, 2251, 2251B, 2251TMB, JTY-GD-2451, 2451 (Heat detectors).

(o) - To be installed in moderate climates where the ambient air temperature will not fall outside the range of 32F to 131F (0C to 55C).

(p) - Special application, system sensitivity may be set between 0.02 and 0.5 percent per foot obscuration.

(q) - Complimentary listed to UL 464 (ULSZ).

(r) - Duct housing can be used with the following compatible detector heads: Models 63-1062, 63-1057, and TC906D1006

Last Updated on 2011-08-09

[Questions?](#)

[Print this page](#)

[Notice of Disclaimer](#)

[Page Top](#)

Copyright © 2011 Underwriters Laboratories Inc.®

The appearance of a company's name or product in this database does not in itself assure that products so identified have been manufactured under UL's Follow-Up Service. Only those products bearing the UL Mark should be considered to be Listed and covered under UL's Follow-Up Service. Always look for the Mark on the product.

UL permits the reproduction of the material contained in the Online Certification Directory subject to the following conditions: 1. The Guide

Information, Designs and/or Listings (files) must be presented in their entirety and in a non-misleading manner, without any manipulation of the data (or drawings). 2. The statement "Reprinted from the Online Certifications Directory with permission from Underwriters Laboratories Inc." must appear adjacent to the extracted material. In addition, the reprinted material must include a copyright notice in the following format: "Copyright © 2011 Underwriters Laboratories Inc.®"

An independent organization working for a safer world with integrity, precision and knowledge.



NC-100R(A)

Relay Module for FireWarden Series Panels

**Addressable**

General

The **NC-100R(A)** Addressable Relay Module provides NOTIFIER's **FireWarden Series** intelligent control panels with two isolated sets of Form-C dry-contact outputs for activating a variety of auxiliary devices, such as fans, dampers, door holders, control equipment, etc. Addressability allows the dry contact to be activated, either manually or through panel programming, on a select basis.

Features

- Built-in type identification automatically identifies these devices to the control panel.
- Internal circuitry and relay powered directly by two-wire SLC loop.
- Integral LED "blinks" green each time a communication is received from the control panel and turns on in steady when activated.
- High noise immunity (EMF/RFI).
- Wide viewing angle of LED.
- SEMS screws with clamping plates for wiring ease.
- Direct Decade entry of address: 01 – 99 with the FireWarden-100-2(C) and 01 – 50 with the FireWarden-50(C).

Applications

The NC-100R(A) may be programmed to operate dry contacts for door holders, Air Handling Unit shutdown, etc., and to reset four-wire smoke detector power.

Construction

- The face plate is made of off-white heat-resistant plastic.
- Controls include two rotary switches for direct-dial entry of address setting.
- The NC-100R(A) provides two Form-C dry contacts that switch together.

Operation

Each NC-100R(A) uses one of the addresses on a SLC loop. It responds to regular polls from the control panel and reports its type and status. The LED blinks with each poll received. On command, it activates its internal relay.

Rotary switches set a unique address for each module. The address may be set before or after mounting. The built-in TYPE CODE (not settable) will identify the module to the control panel.

**NC-100R(A)**

60379cov.jpg

Specifications

Normal operating voltage: 15 to 32 VDC.

Maximum SLC current draw: 6.5 mA (LED).

Average operating current: 230 μ A direct poll (CLIP mode), 255 μ A group poll with LED flashing.

EOL resistance: not used.

Temperature range: 32°F to 120°F (0°C to 49°C).

Humidity range: 10% to 93% non-condensing.

Dimensions: 4.5" (11.43 cm) high x 4" (10.16 cm) wide x 1.25" (3.175 cm) deep. Mounts to a 4" (10.16 cm) square x 2.125" (5.398 mm) deep box.

Relay Contact Ratings

Load Description	Application	Maximum Voltage	Current Rating
Resistive	Non-Coded	30 VDC	3.0 A
Resistive	Coded	30 VDC	2.0 A
Resistive	Non-Coded	110 VDC	0.9 A
Resistive	Non-Coded	125 VAC	0.9 A
Inductive (L/R=5ms)	Coded	30 VDC	0.5 A
Inductive (L/R=2ms)	Coded	30 VDC	1.0 A
Inductive (PF=0.35)	Non-Coded	125 VAC	0.5 A

Agency Listings and Approvals

In some cases, certain modules may not be listed by certain approval agencies, or listing may be in process. Consult factory for latest listing status.

- **UL/ULC Listed:** S635.
- **CSFM approved:** file 7300-0028:230.
- **FM approved.**
- **MEA approved:** file 72-01-E, Vol. 2.

Product Line Information

NC-100R: Intelligent addressable relay module.

NC-100RA: Intelligent addressable relay module, ULC listed model.

SMB500: Optional surface-mount backbox.

NOTE: For installation instructions, see document 156-2593-001 and refer to the SLC Wiring Manual, document 52304.



NOTIFIER® is a registered trademark of Honeywell International Inc.
©2010 by Honeywell International Inc. All rights reserved. Unauthorized use of this document is strictly prohibited.



This document is not intended to be used for installation purposes.
We try to keep our product information up-to-date and accurate.
We cannot cover all specific applications or anticipate all requirements.
All specifications are subject to change without notice.



Made in the U.S. A.

For more information, contact Notifier. Phone: (203) 484-7161, FAX: (203) 484-7118.
www.notifier.com

Control Unit Accessories, System

COMPANY

NOTIFIER

12 Clintonville Rd
Northford, CT 06472-1610 United States

S635

View model for additional information

Model(s): [ABF-4@](#), [ACM-8R](#), [BB-XP](#), [PRN-6](#)

"Control modules, supply voltage 15-32 Vdc, 6.5 mA maximum", Model(s): [FCM-1](#)

Amplifier - subassembly, Model(s): [NFC-BDA-25](#), [NFC-BDA-70V](#)

Annunciator Loop Repeaters, Model(s): [RPT-485W](#), [RPT-485WF](#)

Audio Transformer, Model(s): [NFC-XRM-70V](#)

Backbox, Model(s): [AFAWS-BX](#)

Battery box Model, Model(s): [BB-25](#)

Cellular Transmitter, Model(s): [CELL-CAB-N](#)

Circuit Expander - subassembly, Model(s): [NFC-CE6](#)

Control Module, Model(s): [FTM-1A \(a\)](#)

Control modules, Model(s): [FRM-1](#), [JKM-FCM-1C](#)

Digital Alarm Communicator Transmitter, Model(s): [UDACT](#), [UDACT-2](#)

Direct Panel Interface, Model(s): [DPI-232](#)

Distributed Audio Panel, Model(s): [FireVoice-25/50DA](#), [FireVoice-25/50DAZS](#)

Doors, Model(s): [AFAWS-KR](#), [AFAWS-KS](#), [AFAWS-LR](#), [AFAWS-LS](#)

Dual monitor modules, Model(s): [FDM-1](#), [FTM-1\[@\]](#)

Emergency Command Center - ACU, Model(s): [NFC-50/100](#), [NFC-50/100E](#)

Enclosure, Model(s): [CAB-RM](#), [CAB-RMR](#)

Fault Isolator Module, Model(s): [ISO-101](#)

Fire fighter telephone station, Model(s): [NFC-FFT](#)

Fire fighters phones, Model(s): [AFAWS-TELA](#), [AFAWS-TELC](#)

Input monitor modules, Model(s): [XP10-M](#)

Input/Output Module, Model(s): [FDRM-1](#)

Local Operator Console, Model(s): [NFC-LOC](#)

Monitor module, Model(s): [FMM-1\[#\]](#)

Monitor modules, Model(s): [FMM-101](#), [FZM1\[@\]](#), [NMM-100P](#), [NMM-100P](#), [NZM-100](#), [NZM-100](#)

Network control annunciators, Model(s): [NCA-2](#)

Quad Intelligent Audio Transponder, Model(s): [XPIQ](#)

Relay Module, Model(s): [XP6-R](#)

Remote annunciators, Model(s): [N-ANN-I/O](#)

Remote Microphone, Model(s): [RM-1](#), [RM-1SA](#)

Remote microphone modules, Model(s): [NFC-RM](#)

Remote Notification Circuit Expander/Battery Charger, Model(s): [FCPS-24FS6E](#)

Remote paging unit, Model(s): [NFC-RPU](#)

Remote Repeater Modules, Model(s): [RPT-E](#), [RPT-W](#), [RPT-WF](#)

Serial/parallel interfaces, Model(s): [N-ANN-S/PG](#)

Six Zone Interface Module, Model(s): [XP6-MA](#)

Subassembly, Model(s): [ABF-1B \[a\]](#), [ABF-1D](#), [ABF-1DB \[a\]](#), [ABF-2@](#), [ABF-2B \[a\]](#), [ABF-2DB \[a\]](#), [ABF-4B \[a\]](#), [ABS-1@](#), [ABS-1T@](#), [ABS-1TB \[a\]](#), [ABS-2@](#), [ABS-2D \[a\]](#), [ABS-2DR \[a\]](#), [ABS-4DR \[a\]](#), [ABS-8R@](#), [ACM-16AT](#), [ACM-16ATG](#), [ACM-16ATY](#), [ACM-32A](#), [ACM-32AG](#), [ACM-32AY](#), [ADDR-B4 \[a\]](#), [ADDR-B4R \[a\]](#), [ADDR-C4 \[a\]](#), [ADDR-C4R \[a\]](#), [ADDR-D4 \[a\]](#), [ADDR-D4R \[a\]](#), [AEM-16AT](#), [AEM-16ATG](#), [AEM-16ATY](#), [AEM-32A](#), [BP2-4 \[a\]](#), [BP-4 \[a\]](#), [CAB-3](#), [CAB-3B](#), [CAB-RP \[a\]](#), [CAB-RPR \[a\]](#), [DR- C4R \[a\]](#), [DR-A4B \[a\]](#), [DR-A4BR \[a\]](#), [DR-A4R \[a\]](#), [DR-B4B \[a\]](#), [DR-B4BR \[a\]](#), [DR-B4R \[a\]](#), [DR-C4B \[a\]](#), [DR-C4BR \[a\]](#), [DR-D4B \[a\]](#), [DR-D4BR \[a\]](#), [DR-D4R \[a\]](#), [NFS-LBB \[a\]](#), [NFS-LBBR \[a\]](#), [XPIQ-AA2270](#), [XPIQ-AA25](#), [XPIQ-AIB1](#), [XPIQ-AIB4](#), [XPIQ-CA](#), [XPIQ-MB](#), [XPIQ-MBPCB](#), [XPIQ-PS](#), [XPIQ-PSE](#), [XPIQ-RMJ](#), [XPIQ-SLI](#)

Supervising Control Module, Model(s): [XP6-C](#)

Investigated to UL 864 (10th edition)

Model(s): [AMPS-24/E](#)

Annunciator control modules, remote, input 24 V dc, 56 mA, Model(s): [ACM-24AT \(f14\)](#), [ACM-48A \(f14\)](#)

Annunciator expander modules, remote, input 24 V dc, 18 mA, Model(s): [AEM-24AT \(f14\)](#), [AEM-48A \(f14\)](#)

Annunciator Keyswitch, Model(s): [AKS-1](#), [AKS-1B](#)

Backbox Series, Model(s): [CAB-AA4](#), [CAB-AA4\(a\)](#)

Battery boxes, Model(s): [BB-17](#), [BB-55](#), [NFS-LBB](#), [NFS-LBBR](#)

End of line resistors, Model(s): [401-4901](#), [401-4902](#), [75603](#), [ELR-47K](#), [R-10K](#), [R-47K](#)

End of line supervision devices, Model(s): [REL-2.2K](#), [REL-3.3K](#), [REL-4.7K](#), [REL-47K](#)

Lamp driver annunciator modules, Model(s): [LDM-32\(f03\)](#), [LDM-E32\(f03\)](#), [LDM-R32\(f03\)](#).

Network control annunciators, input 24 V dc, 483 mA, Model(s): [NCA-2-HE](#), [NCA-2-KO](#), [NCA-2-PO](#), [NCA-2-RU](#), [NCA-2-SC](#), [NCA-2-SP](#), [NCA-2-TC](#), [NCA-2-TH](#)

Network Control Display, Model(s): [NCD](#)

Power supply expander, Model(s): [PSE-10](#), [PSE-10E](#), [PSE-6](#), [PSE-6E](#)

Remote annunciators, Model(s): [FDU-80](#), [LCD-160\(f11\)](#), [LCD-160-HE\(f11\)&](#), [LCD-160-KO\(f11\)&](#), [LCD-160-PO\(f11\)&](#), [LCD-160-RU\(f11\)&](#), [LCD-160-SC\(f11\)&](#), [LCD-160-SP\(f11\)&](#), [LCD-160-TC\(f11\)&](#), [LCD-160-TH\(f11\)&](#)

Remote annunciators, input 18.8-38.2 VDC, 48 mA, Model(s): [N-ANN-80W](#)

Remote annunciators, 24 V dc 100 mA, Model(s): [LCD2-80](#), with [ABS-1T](#) and [ABF-1](#) backboxes and [AKS-1](#) key switch, the [ABF-1](#) may include the [AKS-1](#) key switch

Remote annunciators, input 18.8-38.2 VDC, 48 mA, Model(s): [N-ANN-80](#)

Subassembly, Model(s): [ABM-32A](#) dress panel

Subassembly, Backbox, Model(s): [SBB-A4+](#), [SBB-B4+](#), [SBB-C4+](#), [SBB-D4+](#)

Subassembly, battery holder chassis, Model(s): [CHS-BH1](#)

Subassembly, chassis, Model(s): [CHS-2D](#), [CHS-4L](#)

Subassembly, Class A converter, Model(s): [ZNAC-PS](#)

Subassembly, CPU board, Model(s): [CPU-NCD-RB](#)

Subassembly, Door, Model(s): [ADDR-B4+](#), [ADDR-C4+](#), [ADDR-D4+](#), [DR-A4+](#), [DR-AA4](#), [DR-AA4BR](#), [DR-AA4R](#), [DR-B4+](#), [DR-C4+](#), [DR-D4+](#), [EQDR-B4+](#), [EQDR-C4+](#), [EQDR-D4+](#)

Subassembly, dress panel, Model(s): [DPA-1](#), [DPA-2](#), [DP-GDIS1](#), [DP-GDIS2](#)

Subassembly, enclosure, Model(s): [ABF-1](#), [ABF-1/B](#), [ABF-1/D](#), [ABF-1/F](#), [ABF-1/R](#), [ABF-2](#), [ABF-2/B](#), [ABF-2/D](#), [ABF-2/F](#), [ABF-2/R](#), [ABF-4](#), [ABF-4/B](#), [ABF-4/F](#), [ABF-4/R](#), [ABS-1](#), [ABS-1/B](#), [ABS-1/F](#), [ABS-1/R](#), [ABS-1T](#), [ABS-1T/B](#), [ABS-1T/F](#), [ABS-1T/R](#), [ABS-2](#), [ABS-2/B](#), [ABS-2/F](#), [ABS-2/R](#), [ABS-2D\(+\)](#), [ABS-2D/B](#), [ABS-2D/F](#), [ABS-2D/R](#), [ABS-4D\(+\)](#), [ABS-4D/B](#), [ABS-4D/F](#), [ABS-4D/R](#), [ABS-8R](#), [ABS-8RB](#), [ABS-8RE](#), [ABS-TD](#), [BB-100](#), [BB-100R](#), [BB-200](#), [BB-200R](#), [BB-UZC](#), [CA-1](#), [CA-2](#), [CAB-A4+](#), [CAB-B4+](#), [CAB-C4+](#), [CAB-D4+](#), [CAB-PS1](#), [CAB-RP](#), [CAB-RPR](#), [EQBB-B4+](#), [EQBB-C4+](#), [EQBB-D4+](#), [SBB-AA4](#), [SBB-AA4B](#), [SBB-AA4R](#)

Subassembly, High speed network communication module, Model(s): [HS-NCM-MFSE](#), [HS-NCM-SF](#), [HS-NCM-W](#), [HS-NCM-W-2](#), [HS-NCM-WMF](#), [HS-NCM-WMF-2](#), [HS-NCM-WSF](#), [HS-NCM-WSF-2](#)

Subassembly, microphone chassis, Model(s): [CMIC-1](#)

Subassembly, Power Supply, Model(s): [APS2-6RE](#)

Subassembly, Retrofit Adapter Plate, Model(s): [DP-ADP](#), [DP-NCD-2D](#), [RLD-1DB-RTO](#)

Supervised isolated relay module, Model(s): [FRM-1-ISO](#)

Universal zone coder module, Model(s): [UZC-256](#)

Wireless driver, Model(s): [FWUI-DD](#)

Wireless gateway, Model(s): [FWSG](#)

Investigated to UL 864 (10th edition), ULC S527

Addressable charger/power supplies, input 120 Vac, 50/60Hz 5.0A, Model(s): [ACPS-610](#)

Addressable charger/power supplies, input 220-240 Vac 50/60 Hz, 2.5A, for use with ULC listed notifier control units, Model(s): [ACPS-610E](#)

Annunciator, Model(s): [RLD](#)

End of line device, Model(s): [ELRD-2.2K](#)

High Level Interface (HLI) network card, Model(s): [VHX-1420-HFS](#)

Power supply expander, Model(s): [PSE-10C](#), [PSE-10R](#), [PSE-6C](#), [PSE-6R](#)

Remote Ancillary display/ Remote Annunciator, Model(s): [N-ANN-100](#), [N-ANN-100R](#)

Subassembly, Annunciator control module, Model(s): [ACM-30](#)

Subassembly, Dress panel, Model(s): [DP-4A-CB4](#), [DP-T2A-CB4](#)

Subassembly, Enclosure, Model(s): [ABB-1](#), [ABB-2](#)

Subassembly, High speed networkcommunication module, Model(s): [HS-NCM-MF](#)

Subassembly, Lamp Driver Module, Model(s): [LDM2-32](#), [LDM2-60](#)

Subassembly, Power Supply, Model(s): [APS2-6R](#)

Subassembly, Retrofit Adapter Plate, Model(s): [ACM-1DB-RTO](#)

Subassembly, Transmitter Module, Model(s): [TM-8](#)

Investigated to UL 864 (9th edition)

Audio fiber modules, Model(s): [AFL-R](#), [AFL-RM](#), [AFL-RS](#), [AFL-T](#), [AFL-TM](#), [AFL-TS](#)

Control modules, Model(s): [FCM-1-REL](#), [NC-100](#), [NC-100](#), [NC-100R](#), [NC-100R](#)

Control modules, supply voltage 15-32 Vdc, 6.5 mA maximum, Model(s): [FCM-1 \(f13\)](#), [JKM-FCM-1 \(f13\)](#), [JKM-FCM-1C \(f13\)](#)

Dual Monitor Module, Model(s): [NDM-100](#)

Enclosures, Model(s): [DR-PS1](#), [ROME-B](#)

End of line resistors, Model(s): [A2143-00](#)

Fault Isolator Module, Model(s): [ISO-9G](#), [N100-ISO](#), [TC961A1006](#)

Fault isolator modules, Model(s): [ISO-X](#)

Fire alarm subassemblies, Model(s): [ACC-EPM](#), [ACC-ZSM](#), [NFV-FFT](#), [NFV-ZPMK](#)

Firefighter phone jacks, Model(s): [N-FPJ](#)

Input monitor modules, Model(s): [NMM-100](#), [NMM-100-10](#), [NMM-100-10](#)

Input/output relay modules, 15-32 Vdc, 2 mA, Model(s): [JSKM-CMM-9G](#)

Interface Module, Model(s): [KM-FZM-9G](#), [KM-TC962A](#)

Liquid crystal display remote annunciators, 24 V 100 mA, Model(s): [LCD-80\(f07\)](#)

Monitor Module, Model(s): [JSM-FMM-9G](#), [JSM-TC959A1059](#), [MMX-101 \(a\)](#) (a) - UOXX only

Monitor modules, 15-32 Vdc, 5.0 mA max, Model(s): [JSM-FMM-1](#), [JSM-FMM-1C](#)

Monitor modules, 15-32 Vdc, 5.1 mA max, Model(s): [KM-FZM-1C](#)

Monitor modules, 15-32 Vdc, 600 uA max, Model(s): [JSM-FMM-101C](#)

Power supply circuit extender and battery chargers, Model(s): [FCPS-24FS6](#), [FCPS-24FS8](#), [FCPS-24FS8E](#)

Relay modules, input 24 V dc, 75 mA, individual relay contacts rated 30 Vac, 0.5 A resistive, 30 V dc, 2 A resistive, Model(s): [N-ANN-RLY](#)

Remote annunciators, Model(s): [N-ANN-RLED](#)

Remote annunciators, input 18-28V dc, 68mA, Model(s): [N-ANN-LED](#)

Remote microphone modules, Model(s): [VEC-RM](#)

Remote paging jacks, Model(s): [N-RPJ](#), [RPJ-1](#)

Remote zone annunciators, Model(s): [RZA-4X](#), [RZA-4X](#), [RZA-4X](#)

Six Zone interface modules, Model(s): [NZM-100-6](#), [NZM-100-6](#)

Subassemblies, Model(s): [ACC-AAM25](#)

Supervised Control Module, Model(s): [JKM-FCM-9G](#), [JKM-TC960A1066](#)

Voice evacuation control panels, Model(s): [FireVoice 25/50ZST](#), [FireVoice-25/50](#), [FireVoice-25/50ZS](#)

Wireless driver, Model(s): [FWUI-DD](#)

Wireless gateway, Model(s): [FWSG](#)

Wireless monitor module, Model(s): [FW-MM](#), [FW-MM](#)

Wireless relay module, Model(s): [FW-RM](#)

Last Updated on 2025-06-27

The appearance of a company's name or product in this database does not in itself assure that products so identified have been manufactured under UL Solutions' Follow - Up Service. Only those products bearing the UL Mark should be considered to be Certified and covered under UL Solutions' Follow - Up Service. Always look for the Mark on the product.

UL Solutions permits the reproduction of the material contained in Product iQ subject to the following conditions: 1. The Guide Information, Assemblies, Constructions, Designs, Systems, and/or Certifications (files) must be presented in their entirety and in a non-misleading manner, without any manipulation of the data (or drawings). 2. The statement "Reprinted from Product iQ with permission from UL Solutions" must appear adjacent to the extracted material. In addition, the reprinted material must include a copyright notice in the following format: "©2025 UL LLC."



Indoor Selectable-Output Speaker Strobes and Dual Voltage Evacuation Speakers for Ceiling Applications

System Sensor L-Series selectable-output speaker strobes and dual-voltage evacuation speakers can reduce ground faults and enable faster installation with lower current draw and modern aesthetics.

Features

- Plug-in design and protective cover reduce ground faults
- Universal mounting plate with an onboard shorting spring tests wiring continuity before installation
- No extension ring required
- Field selectable candela settings on ceiling units: 15, 30, 75, 95, 115, 150, and 177
- Automatic selection of 12- or 24-volt operation at 15 and 30 candela
- Rotary switch simplifies field selection of speaker voltage (25 and 70.7 Vrms) and power settings (¼, ½, 1 and 2 watts)
- Speakers offer high fidelity and high volume sound output
- 520 Hz capable with compatible FACP
- Compatible with System Sensor synchronization protocol
- Electrical compatibility with existing SpectrAlert and SpectrAlert Advance products
- Tamper-resistant construction
- Updated modern aesthetics

Agency Listings



System Sensor L-Series of speakers and speaker strobes reduce costly ground faults using a plug-in design and universal mounting plate that allow the installer to pre-wire mounting plates, dress the wires, and confirm wiring continuity before plugging in the speakers. In addition, a protective plastic cover prevents nicked wires by covering exposed speaker components.

These devices also enable faster installations by providing instant feedback to ensure that wiring is properly connected, rotary switches to select voltage and power settings, and 7 field-selectable candela settings for both wall and ceiling speaker strobes.

The low total harmonic distortion of the SP speaker offers high fidelity sound output while still offering high volume sound output for use in high ambient noise applications.

L-Series makes installation easy

- Attach a universal mounting plate to a 4 × 4 × 21/8 inch back box. Flush-mount applications do not require an extension ring.
- Connect the notification appliance circuit or speaker wiring to the terminals on the mounting plate.
- Attach the speaker or speaker strobe to the mounting plate by inserting the product tabs into the mounting plate grooves. Hinge the device into position to lock the product pins into the mounting plate terminals. The device will temporarily hold in place with a catch until it is secured with a captured mounting screw.

L-Series Speaker and Speaker Strobe Specifications

Architectural/Engineering Specifications

General

L-Series speaker and speaker strobes shall mount to a 4 × 4 × 21/8-inch back box. A universal mounting plate shall be used for mounting ceiling and wall products. The notification appliance circuit and amplifier wiring shall terminate at the universal mounting plate. Also, L-Series speaker strobes, when used with the Sync•Circuit™ Module accessory, shall be powered from a non-coded notification appliance circuit output and shall operate on a nominal 12 or 24 volts. When used with the Sync•Circuit Module, 12-volt rated notification appliance circuit outputs shall operate between 8.5 and 17.5 volts; 24-volt rated notification appliance circuit outputs shall operate between 16.5 and 33 volts. Indoor L-Series products shall operate between 32°F and 120°F from a regulated DC, or full-wave rectified, unfiltered power supply. Speaker strobes shall have field-selectable candela settings including 15, 30, 75, 95, 115, 150, 177.

Speaker

The speaker shall be a System Sensor L-Series model _____ dual-voltage transformer speaker capable of operating at 25.0 or 70.7 nominal Vrms. It should be listed to UL 1480 and shall be approved for fire protective service. The speaker shall have a frequency range of 400 to 4,000 Hz and shall have an operating temperature between 32°F and 120°F. The speaker shall have power taps and voltage that are selected by rotary switches.

Speaker Strobe combination

The speaker strobe shall be a System Sensor L-Series model _____ listed to UL1480 and UL 1971 and be approved for fire protective signaling systems. The speaker shall be capable of operating at 25.0 or 70.7 nominal Vrms selected via rotary switch, and shall have a frequency range of 400 to 4,000 Hz. The speaker shall have power taps that are selected by rotary switch. The strobe shall comply with the NFPA 72 requirements for visible signaling appliances, flashing at 1 Hz over the strobe's entire operating voltage range. The strobe light shall consist of a xenon flash tube and associated lens/reflector system.

Synchronization Module

The module shall be a System Sensor Sync•Circuit model MDL3 listed to UL 464 and shall be approved for fire protective service. The module shall synchronize SpectrAlert strobes at 1 Hz. The module shall mount to a 411/16 × 411/16 × 21/8-inch back box. The module shall also control two Style Y (class B) circuits or one Style Z (class A) circuit. The module shall synchronize multiple zones. Daisy chaining two or more synchronization modules together will synchronize all the zones they control. The module shall not operate on a coded power supply.

Physical Specifications

Operating Temperature	32°F to 120°F (0°C to 49°C)	
Humidity Range	10 to 93% non-condensing	
Dimensions, Ceiling-Mount	Diameter	Depth
SPC Speaker	6.8 in, 173 mm	1.0 in, 25 mm
With Surface Mount Back Box	6.9 in, 176 mm	3.5 in, 89 mm
SPSC Speaker Strobe	6.8 in, 173 mm	2.8 in, 73 mm
With Surface Mount Back Box	6.9 in, 176 mm	5.37 in, 136 mm

Electrical/Operating Specifications

Nominal Voltage (speakers)	25 Volts or 70.7 Volts (nominal)
Maximum Supervisory Voltage (speakers)	50 VDC
Strobe Flash Rate	1 flash per second
Nominal Voltage (strobes)	Regulated 12 VDC or regulated 24 VDC/FWR ^{1,2}
Operating Voltage Range (includes fire alarm panels with built in sync)	8 to 17.5 V (12 V nominal) or 16 to 33 V (24 V nominal)
Operating Voltage with MDL3 Sync Module	8.5 to 17.5 V (12 V nominal) or 16.5 to 33 V (24 V nominal)
Frequency Range	400 to 4,000 Hz ³
Power	¼, ½, 1, 2 watts

1. Full Wave Rectified (FWR) voltage is a non-regulated, time-varying power source that is used on some power supply and panel outputs.
2. Strobe products will operate at 12 V nominal only for 15 and 30 cd.
3. 520Hz capable with compatible FACP.

UL Current Draw Data

UL Max. Strobe Current Draw (mA RMS)			
	8 to 17.5 Volts	16 to 33 Volts	
Candela	DC	DC	FWR
15	87	41	60
30	153	63	86
75	NA	111	142
95	NA	134	164
115	NA	158	191
150	NA	189	228
177	NA	226	264

Ceiling-Mount Speaker Sound Output		
Setting	UL Reverberant (dBA @ 10 ft)	UL Anechoic (dBA @ 10 ft)
1/4 W	79	79
1/2 W	82	82
1 W	85	85
2 W	88	88

Ceiling-Mount Speaker Strobe Sound Output		
Setting	UL Reverberant (dBA @ 10 ft)	UL Anechoic (dBA @ 10 ft)
1/4 W	77	77
1/2 W	80	80
1 W	83	83
2 W	86	86

L-Series Dimensions

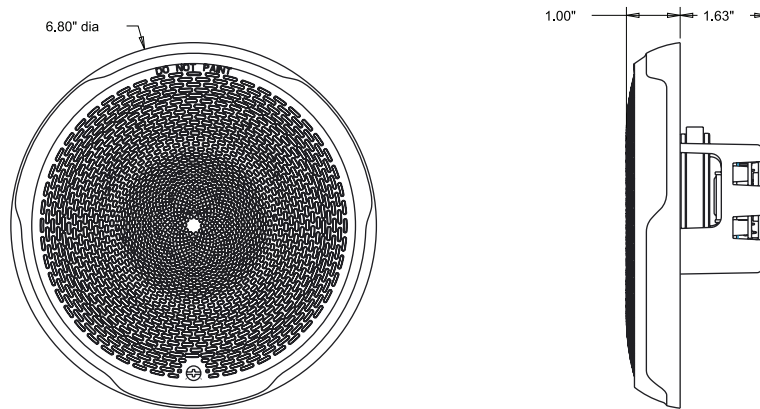

Ceiling Speaker

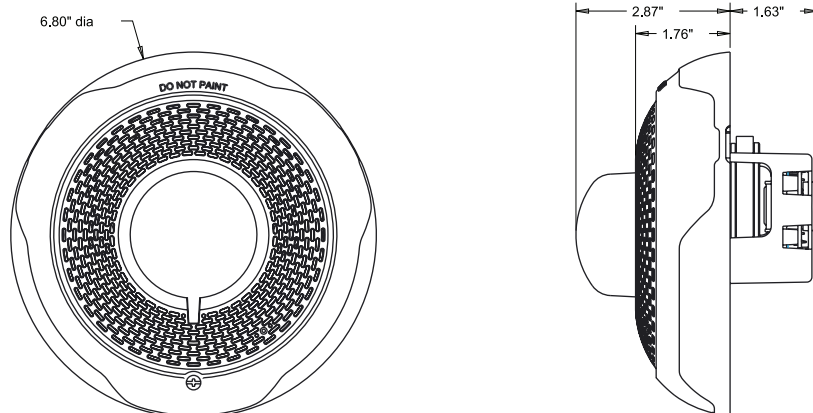

Ceiling Speaker Strobe

Surface Mounting

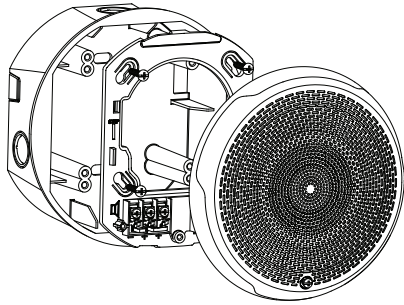

Ceiling Speaker with Surface Mount Back Box

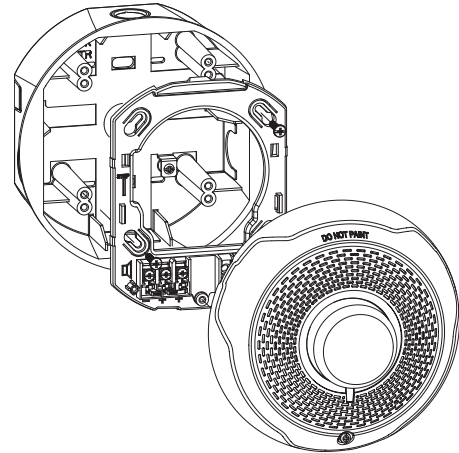

Ceiling Speaker Strobe with Surface Mount Back Box

L-Series Ordering Information

Ceiling Mount		
White	Red	Description
SPCWL	SPCRL	Speaker only
SPSCWL	SPSCRL	Speaker Strobe
SPSCWL-P	—	Plain, Speaker Strobe
SPSCWL-SP	—	Fuego, Speaker Strobe
SPSCWL-CLR-ALERT	—	Alert, Speaker Strobe, Clear Lens
Accessories		
White	Red	Description
SBBCWL	SBBCRL	Universal Ceiling Surface Mount Back Box
TRC-2W	TRC-2	Universal Ceiling Trim Ring



3825 Ohio Avenue • St. Charles, IL 60174
 Phone: 800-SENSOR2 • Fax: 630-377-6495
www.systemsensor.com

©2017 System Sensor.
 Product specifications subject to change without notice. Visit systemsensor.com
 for current product information, including the latest version of this data sheet.
 AVDS86601 • 03/17



UUMW.S4048 Speakers and Amplifiers for Fire-protective Signaling Systems

[Page Bottom](#)

Speakers and Amplifiers for Fire-protective Signaling Systems

[See General Information for Speakers and Amplifiers for Fire-protective Signaling Systems](#)**SYSTEM SENSOR UNINCORPORATED, DIV OF HONEYWELL INTERNATIONAL INC**

S4048

3825 Ohio Ave
Saint Charles, IL 60174-5467 USA

- #Speakers for indoor/damp use wall or ceiling mounting, Model(s) SPCRL, SPCWL, SPRL, SPWL
- #Speakers/strobes with rectangular enclosures, for indoor wall mounting use, Model(s) SPSRL-SP
- #Speakers/strobes with rectangular enclosures, for indoor wall/ceiling mouning use, Model(s) SPSRL, SPSRL-P
- #Speakers/strobes with rectangular enclosures, for indoor wall/ceiling mounting use, Model(s) SPSWL, SPSWL-ALERT, SPSWL-CLR-ALERT, SPSWL-P
- #Speakers/strobes with round enclosures, for indoor wall/ceiling mouning use, Model(s) SPSCRL, SPSCWL, SPSCWL-CLR-ALERT, SPSCWL-P, SPSCWL-SP
- Accessories, back boxes (rectangular), for indoor surface mounting use, "Spectralert Advance Series", Model(s) SBBSPR, SBBSPW
- Accessories, back boxes (round), for indoor surface mounting use, "Spectralert Advance Series", Model(s) SBBCR, SBBCW
- Accessories, backbox skirts (rectangular), for surface mounting, "Spectralert Advance Series", Model(s) SPBBS, SPBBSW
- Accessories, backbox skirts (reound), for surface mounting, "Spectralert Advance Series", Model(s) SPBBSC, SPBBSCW
- Accessories, retrofit plates, "Spectralert Advance Series", Model(s) RFP, RFPW
- Accessories, trim rings (rectangular), "Spectralert Advance Series", Model(s) TR, TRW
- Accessories, trim rings (round), "Spectralert Advance Series", Model(s) TRC, TRCW
- Accessory, Ceiling Tile Support Bracket, Model(s) SB-SPC8
- Speaker for indoor damp and dry use, suitable for use in air handling spaces, Model(s) SPCW8
- Speaker Strobes Only - Trim Rings - Ceiling Mount trim ring Round, Red,bulk pack-5, "L-Series", Model(s) TRC-2
- Speaker Strobes Only - Trim Rings - Ceiling Mount trim ring Round, White,bulk pack-5, "L-Series", Model(s) TRC-2W
- Speaker Strobes Only - Trim Rings - Wall-Mount trim ring Rectangular, Red, bulk pack-5, "L-Series", Model(s) TR-2
- Speaker Strobes Only - Trim Rings - Wall-Mount trim ring Rectangular, White,bulk pack-5, "L-Series", Model(s) TR-2W
- Speakers with rectangular enclosures, for indoor wall/ceiling mouning use, "Spectralert Advance Series", Model(s) SPR, SPRV
- Speakers with rectangular enclosures, for indoor wall/ceiling mounting use, "Spectralert Advance Series", Model(s) SPW, SPWV
- Speakers with round enclosures, for indoor wall/ceiling mouning use, "Spectralert Advance Series", Model(s) SPCR, SPCRV, SPCW, SPCWV
- Speakers, for indoor use, Model(s) SP200R, SP200W, SP201R, SP201W, SP300W, SP301R, SP301W
- Speakers, for indoor/outdoor use, Model(s) SP201K
- Speakers/Speaker Strobes Ceiling Bezel Kits - Ceiling Bezel Kit with AGENT red lettering, "L-Series", Model(s) BZSPWC-AG
- Speakers/Speaker Strobes Ceiling Bezel Kits - Ceiling Bezel Kit with AGENT white lettering, "L-Series", Model(s) BZSPRC-AG
- Speakers/Speaker Strobes Ceiling Bezel Kits - Ceiling Bezel Kit with ALERT red lettering, "L-Series", Model(s) BZSPWC-AL
- Speakers/Speaker Strobes Ceiling Bezel Kits - Ceiling Bezel Kit with ALERT white lettering, "L-Series", Model(s) BZSPRC-AL
- Speakers/Speaker Strobes Ceiling Bezel Kits - Ceiling Bezel Kit with EVAC red lettering, "L-Series", Model(s) BZSPWC-EV
- Speakers/Speaker Strobes Ceiling Bezel Kits - Ceiling Bezel Kit with EVAC white lettering, "L-Series", Model(s) BZSPRC-EV
- Speakers/Speaker Strobes Ceiling Bezel Kits - Ceiling Bezel Kit with FIRE red lettering, "L-Series", Model(s) BZSPWC-F
- Speakers/Speaker Strobes Ceiling Bezel Kits - Ceiling Bezel Kit with FIRE white lettering, "L-Series", Model(s) BZSPRC-F



Indoor Selectable-Output Strobes and Horn Strobes for Ceiling Applications

System Sensor L-Series audible visible notification products are rich with features guaranteed to cut installation times and maximize profits with lower current draw and modern aesthetics.



Features

- Plug-in design with minimal intrusion into the back box
- Tamper-resistant construction
- Automatic selection of 12- or 24-volt operation at 15 and 30 candela
- Field-selectable candela settings on ceiling units: 15, 30, 75, 95, 115, 150, and 177
- Horn rated at 88+ dBA at 16 volts
- Rotary switch for horn tone and two volume selections
- Universal mounting plate for ceiling units
- Mounting plate shorting spring feature checks wiring continuity before device installation
- Electrically Compatible with legacy SpectrAlert and SpectrAlert Advance devices
- Compatible with MDL3 sync module
- Listed for ceiling mounting only

The System Sensor L-Series offers the most versatile and easy-to-use line of horns, strobes, and horn strobes in the industry with lower current draws and modern aesthetics. With white and red plastic housings, wall and ceiling mounting options, System Sensor L-Series can meet virtually any application requirement.

The entire L-Series product line of ceiling-mount strobes and horn strobes include a variety of features that increase their application versatility while simplifying installation. All devices feature a plug-in design with minimal intrusion into the back box, making installations fast and foolproof while virtually eliminating costly and time-consuming ground faults.

To further simplify installation, the L-Series utilizes a universal mounting plate so installers can mount them to a wide array of back boxes. With an onboard shorting spring, installers can test wiring continuity before the device is installed.

Installers can also easily adapt devices to suit a wide range of application requirements using field-selectable candela settings, automatic selection of 12- or 24-volt operation, and a rotary switch for horn tones with two volume selections.

Agency Listings



S5512
S4011



FM approved except
for ALERT models
3057383



7125-1663:0504
7135-1663:0503

L-Series Specifications

Architect/Engineer Specifications

General

L-Series ceiling-mount strobes and horn strobes shall mount to a standard 4 × 4 × 1½-inch back box, 4-inch octagon back box, or double-gang back box. Two-wire products shall also mount to a single-gang 2 × 4 × 17/8-inch back box. A universal mounting plate shall be used for mounting ceiling and wall products. The notification appliance circuit wiring shall terminate at the universal mounting plate. Also, L-Series products, when used with the Sync•Circuit™ Module accessory, shall be powered from a non-coded notification appliance circuit output and shall operate on a nominal 12 or 24 volts. When used with the Sync•Circuit Module, 12-volt-rated notification appliance circuit outputs shall operate between 8.5 and 17.5 volts; 24-volt-rated notification appliance circuit outputs shall operate between 16.5 and 33 volts. Indoor L-Series products shall operate between 32 and 120 degrees Fahrenheit from a regulated DC or full-wave rectified unfiltered power supply. Ceiling strobes and horn strobes shall have field-selectable candela settings including 15, 30, 75, 95, 115, 150, and 177.

Strobe

The strobe shall be a System Sensor L-Series Model _____ listed to UL 1971 and shall be approved for fire protective service. The strobe shall be wired as a primary-signaling notification appliance and comply with the Americans with Disabilities Act requirements for visible signaling appliances, flashing at 1 Hz over the strobe's entire operating voltage range. The strobe light shall consist of a xenon flash tube and associated lens/reflector system.

Horn Strobe Combination

The horn strobe shall be a System Sensor L-Series Model _____ listed to UL 1971 and UL 464 and shall be approved for fire protective service. The horn strobe shall be wired as a primary-signaling notification appliance and comply with the Americans with Disabilities Act requirements for visible signaling appliances, flashing at 1 Hz over the strobe's entire operating voltage range. The strobe light shall consist of a xenon flash tube and associated lens/reflector system. The horn shall have two audibility options and an option to switch between a temporal three pattern and a non-temporal (continuous) pattern. These options are set by a multiple position switch. The horn on horn strobe models shall operate on a coded or non-coded power supply.

Synchronization Module

The module shall be a System Sensor Sync•Circuit model MDL3 listed to UL 464 and shall be approved for fire protective service. The module shall synchronize L-Series strobes at 1 Hz and horns at temporal three. Also, while operating the strobes, the module shall silence the horns on horn strobe models over a single pair of wires. The module shall mount to a 4 11/16 × 4 11/16 × 2 1/8-inch back box. The module shall also control two Style Y (class B) circuits or one Style Z (class A) circuit. The module shall synchronize multiple zones. Daisy chaining two or more synchronization modules together will synchronize all the zones they control. The module shall not operate on a coded power supply.

Physical/Electrical Specifications

Standard Operating Temperature	32°F to 120°F (0°C to 49°C)
Humidity Range	10 to 93% non-condensing
Strobe Flash Rate	1 flash per second
Nominal Voltage	Regulated 12 VDC or regulated 24 DC/FWR ¹
Operating Voltage Range²	8 to 17.5 V (12 V nominal) or 16 to 33 V (24 V nominal)
Operating Voltage Range (MDL3)	8.5 to 17.5V (12 V nominal) or 16.5 to 33 V (24V nominal)
Input Terminal Wire Gauge	12 to 18 AWG
Ceiling-Mount Dimensions (including lens)	6.8" diameter × 2.5" high (173 mm diameter × 64 mm high)
Ceiling-Mount Surface Mount Back Box Skirt Dimensions (SBBCL, SBBCLW)	6.9" diameter × 3.4" high (175 mm diameter × 86 mm high)

Notes:

1. Full Wave Rectified (FWR) voltage is a non-regulated, time-varying power source that is used on some power supply and panel outputs.
2. P, S, PC, and SC products will operate at 12 V nominal only for 15 and 30 cd.

UL Current Draw Data

UL Max. Strobe Current Draw (mA RMS)			
Candela	8–17.5 Volts		16–33 Volts
	DC	DC	FWR
15	87	41	60
30	153	63	86
75	N/A	111	142
95	N/A	134	164
115	N/A	158	191
150	N/A	189	228
177	N/A	226	264

UL Max. Current Draw (mA RMS), 2-Wire Horn Strobe									
DC Input	8-17.5 Volts		16-33 Volts						
	15cd	30cd	15cd	30cd	75cd	95cd	115cd	150cd	177cd
Temporal High	103	167	71	90	143	165	187	217	254
Temporal Low	96	165	54	71	137	161	185	211	249
Non-Temporal High	106	173	71	90	141	165	187	230	273
Non-Temporal Low	95	166	54	71	124	161	170	216	258
3.1K Temporal High	111	164	69	94	147	163	184	229	257
3.1K Temporal Low	103	163	54	88	143	155	185	212	252
3.1K Non-Temporal High	111	172	69	94	144	164	202	229	271
3.1K Non-Temporal Low	103	169	54	88	131	155	187	217	259
FWR Input	16-33 Volts								
	15cd	30cd	75cd	95cd	115cd	150cd	177cd		
Temporal High	107	135	179	198	223	254	286		
Temporal Low	78	101	151	172	199	229	262		
Non-Temporal High	107	135	179	198	223	254	286		
Non-Temporal Low	78	101	151	172	199	229	262		
3.1K Temporal High	108	135	179	200	225	255	289		
3.1K Temporal Low	79	101	150	171	196	229	260		
3.1K Non-Temporal High	108	135	179	200	225	255	289		
3.1K Non-Temporal Low	79	101	150	171	196	229	260		

Horn Strobe Tones and Sound Output Data

Horn and Horn Strobe Output (dBA)					
Switch Position	Sound Pattern	dB	8–17.5 Volts	16–33 Volts	FWR
			DC	DC	
1	Temporal	High	84	89	89
2	Temporal	Low	75	83	83
3	Non-Temporal	High	85	90	90
4	Non-Temporal	Low	76	84	84
5	3.1 KHz Temporal	High	83	88	88
6	3.1 KHz Temporal	Low	76	82	82
7	3.1 KHz Non-Temporal	High	84	89	89
8	3.1 KHz Non-Temporal	Low	77	83	83

L-Series Dimensions

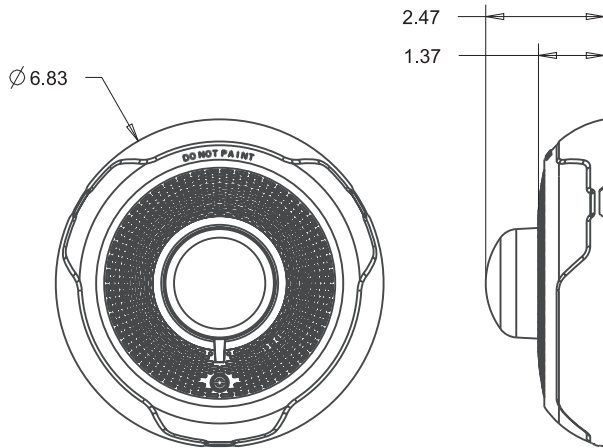

Ceiling-Mount Horn Strobes

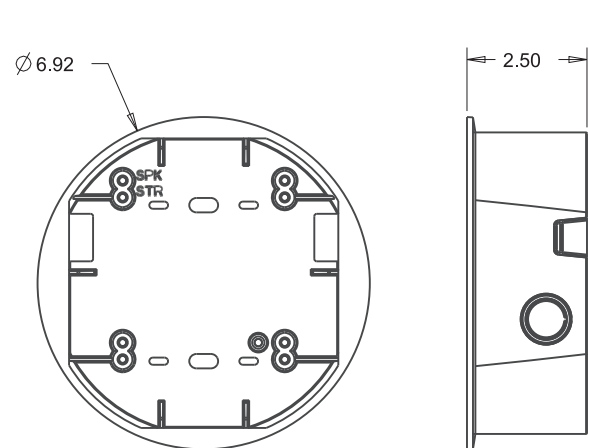

Ceiling Surface Mount Back Box

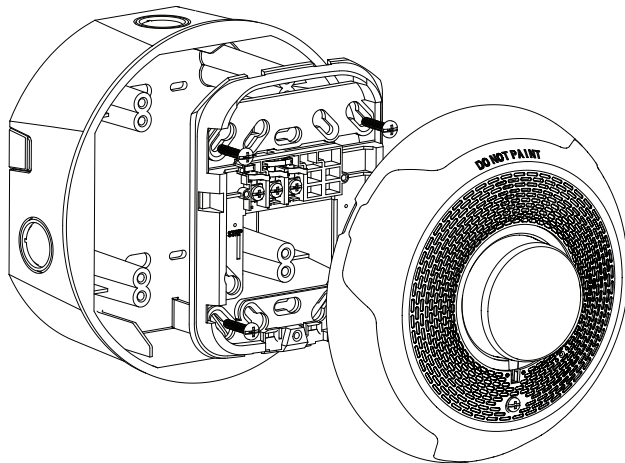

Ceiling Mount Horn Strobes with Ceiling Surface Mount Back Box

L-Series Ordering Information

Model	Description
Ceiling Horn Strobes	
PC2RL	2-Wire, Horn Strobe, Red
PC2WL	2-Wire, Horn Strobe, White

Model	Description
Ceiling Strobes	
SCRL	Strobe, Red
SCWL	Strobe, White
SCWL-CLR-ALERT	Strobe, White, ALERT
Accessories	
TRC-2	Universal Ceiling Trim Ring Red
TRC-2W	Universal Ceiling Trim Ring White
SBBCRL	Ceiling Surface Mount Back Box, Red
SBBCWL	Ceiling Surface Mount Back Box, White





UUKC.S5512 Signaling Appliances and Equipment for the Hearing Impaired

[Page Bottom](#)

Signaling Appliances and Equipment for the Hearing Impaired

[See General Information for Signaling Appliances and Equipment for the Hearing Impaired](#)**SYSTEM SENSOR UNINCORPORATED, DIV OF HONEYWELL INTERNATIONAL INC**

S5512

3825 Ohio Ave
Saint Charles, IL 60174-5467 USA

Strobe light accessories, colored lens, for private mode signaling use, Model(s) LENS-A2, LENS-AC2, LENS-B2, LENS-BC2, LENS-G2, LENS-GC2, LENS-R2, LENS-RC2

Strobe lights with low frequency sounder, Model(s) P2RH-LF, P2WH-LF

Strobe lights, synchronous type, Model(s) SCRL(A)*, **SCWL(A)***, SCWL-CLR-ALERT*, SGRL(A)*, SGWL(A)*, SRL(A)*, SRL(A)-P*, SRL-SP*, SWL(A)*, SWL(A)-P*, SWL-ALERT*, SWL-CLR-ALERT*

Strobe lights, synchronous type, when used with the MDL Synchronization Protocol, 135, 150, 177 or 185 cd, round shape enclosure, for indoor use on wall or ceiling, Model(s) SCR, SCR-P, SCR-PG, SCR-SP, SCRH, SCRH-P, SCRH-PG, SCRH-SP, SCW, SCW-CLR-ALERT, SCW-CLR-ALERT-P, SCW-CLR-ALERT-PG, SCW-CLR-ALERT-SP, SCW-P, SCW-PG, SCW-SP, SCWH, SCWH-P, SCWH-PG, SCWH-SP

Strobe lights, synchronous type, when used with the MDL Synchronization Protocol, 15, 15/75, 30, 75, 95, 110, or 115 cd, rectangular shape enclosure, for indoor use on wall or ceiling, Model(s) SR, SR-P, SR-PG, SR-SP, SRH, SRH-P, SRH-PG, SRH-SP, SW, SW-CLR-ALERT, SW-CLR-ALERT-P, SW-CLR-ALERT-PG, SW-CLR-ALERT-SP, SW-P, SW-PG, SW-SP, SWH, SWH-P, SWH-PG, SWH-SP

Visual signal appliance accessories, accessory retrofit trim plate, Model(s) RFP+, RFPW+

Visual signal appliance accessories, accessory trim ring, Model(s) TR-HS+, TRC-HS+, TRCW-HS+, TRW-HS+

* - Where A suffix Canadian models may have added suffixes -E for English, -F for French, -P for plain versions with no wording.

+ - Optional with Series SR, Series SW, Series SCR or Series SCW synchronous type strobe lights.

[Last Updated](#) on 2017-11-27[Questions?](#)[Print this page](#)[Terms of Use](#)[Page Top](#)

© 2017 UL LLC

The appearance of a company's name or product in this database does not in itself assure that products so identified have been manufactured under UL's Follow-Up Service. Only those products bearing the UL Mark should be considered to be Certified and covered under UL's Follow-Up Service. Always look for the Mark on the product.

UL permits the reproduction of the material contained in the Online Certification Directory subject to the following conditions: 1. The Guide Information, Assemblies, Constructions, Designs, Systems, and/or Certifications (files) must be presented in their entirety and in a non-misleading manner, without any manipulation of the data (or drawings). 2. The statement "Reprinted from the Online Certifications Directory with permission from UL" must appear adjacent to the extracted material. In addition, the reprinted material must include a copyright notice in the following format: "© 2017 UL LLC".



SHOP DRAWING / SUBMITTAL REVIEW	
<input type="checkbox"/> REVIEWED	<input type="checkbox"/> REVIEWED AS NOTED
<input type="checkbox"/> REVISE AND RESUBMIT	<input type="checkbox"/> REJECTED
Project No.: 2508	Submittal No.: 22 14 00.01
<small>Corrections or comments made on the shop drawings during this review do not relieve the contractor from compliance with requirements of the drawings and specifications. This check is only for review of the general conformance with the design concept of the project and general compliance with the information given in the contract documents. This contractor is responsible for: confirming and correlating all quantities and dimensions; selecting fabrication processes and techniques of construction; coordinating his or her work with that and other trades and performing all in a safe and satisfactory manner.</small>	
By: <i>David Hamon</i>	Date: 9/25/2025
DAMMON ENGINEERING, INC. Sidel, LA	

30 VETERANS MEMORIAL BLVD
KENNER, LA 70062

FIRE ALARM

SYSTEM FOR:

332 N NEW HAMPSHIRE
SIS OFFICE SPACE

332 N NEW HAMPSHIRE ST. COVINGTON, LA 70433

SHOP DRAWINGS

ELECTRICAL CONTRACTOR COCHRAN & GILL SPECIALITIES

SUBMITTED BY: WAYNE GUILLOT JR

FIRE ALARM - SECURITY - VIDEO SURVEILLANCE - CARD ACCESS - SOUND - NURSE CALL

TELEPHONE: (504) 471-0917

FAX: (504) 471-0924

REVIEWED BY:

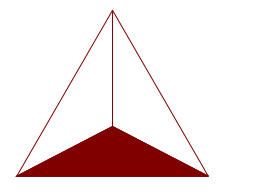

David Theriot
NICET# 133291

Symbol Legend		
SYMBOL	DESCRIPTION	MANUFACTURER
	ADDRESSABLE PHOTO DETECTOR, B300-6 BASE INCLUDED, FLASHSCAN, WHITE, THERMAL	NOTIFIER
	ADDRESSABLE PHOTO DETECTOR, B300-6 BASE INCLUDED, FLASHSCAN ONLY, WHITE	NOTIFIER
	REMOTE TEST CAPABLE ADDRESSABLE PHOTO DETECTOR FLASHSCAN, WHITE	NOTIFIER
	RELAY MODULE, ADDRESSABLE	NOTIFIER
	PULL STATION, ADDRESSABLE	NOTIFIER
	L-Series Speaker Strobe LED, Ceiling, White	SYSTEM SENSOR
	STROBE, CEILING, WHITE	SYSTEM SENSOR
	Generic, EOL, 4.7K Ohms	GENERIC

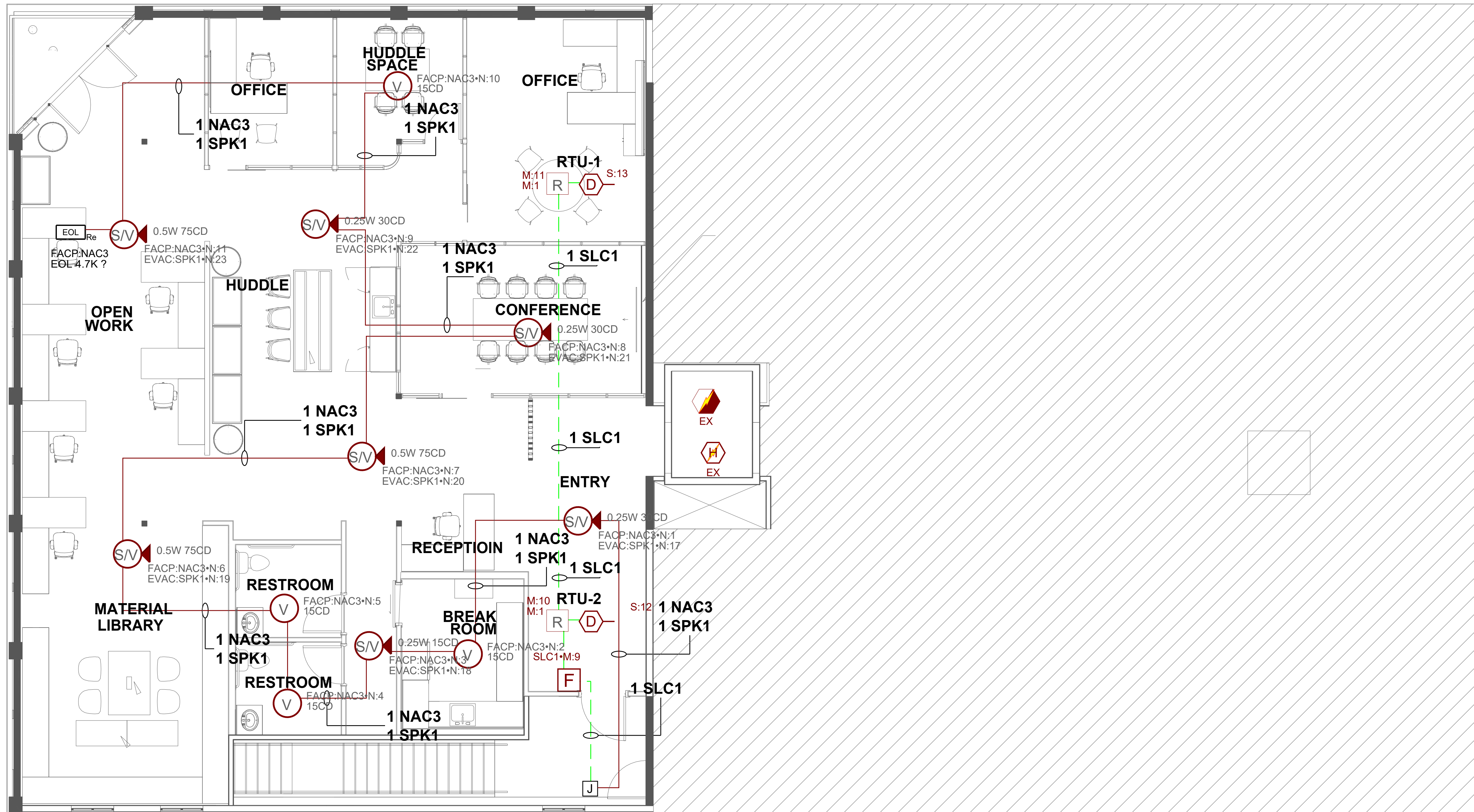

SHOP DRAWING / SUBMITTAL REVIEW

REVIEWED REVIEWED AS NOTED
 REVISE AND RESUBMIT REJECTED

Project No.: 2508 Submittal No.: 22 14 00.01

Corrections or comments made on the shop drawings during this review do not relieve the contractor from compliance with requirements of the drawings and specifications. This check is only for review of the general conformance with the design concept of the project and general compliance with the information given in the contract documents. This contractor is responsible for confirming and correlating all quantities and dimensions; selecting fabrication processes and techniques of construction; coordinating his or her work with that and other trades and performing all in a safe and satisfactory manner.

By: *David Wamson* Date: 9/25/2025
DAMMON ENGINEERING, INC.
 Sibley, LA

NO.	DATE	REVISION DESCRIPTION

332 N NEW HAMPSHIRE
 SIS OFFICE SPACE
 FIRE ALARM SHOP DRAWINGS
 50 VETERANS BLVD. KENNER, LA. 70062. PH. (504)471-0917. FAX (504)471-0924.

DRAWN BY: W. GULLOT	DATE: 09/19/2025
APPROVED BY: W. LEVET	DATE: 09/19/2025
PROJECT NUMBER: ADS# 6390	
SCALE: 1/4"=1'-0"	
SHEET TITLE: 2ND FLOOR	
SHEET NUMBER: FA-01	
01	OF 02

FIRE ALARM SEQUENCE OF OPERATION MATRIX

INITIATION ACTION	MANUAL PULL STATION	SMOKE DETECTOR	DUCT SMOKE DETECTOR	WATER FLOW SWITCH	HEAT DETECTOR	ELEVATOR LOBBY SMOKE DETECTOR	HEAT DETECTOR IN ELEVATOR SHAFT OR PIT	SUPERVISORY VALVE SWITCH	ELEVATOR SHUNT-TRIP SUPERVISION	OPENS, SHORTS, AND GROUNDS ON CIRCUITS	REMOVING, TAMPERING OR OPENING DEVICES	ABNORMAL VOLTAGE, BATTERY OR FACP TROUBLES	ABNORMAL SWITCH POSITION AT FACP	FIRE PUMP AC FAIL DEAD-PHASE, PHASE-REVERSE
CONTINUOUSLY OPERATE ALARM NOTIFICATION DEVICES	X	X	X	X	X	X	X							
TRANSMIT ALARM SIGNAL TO THE MONITORING SERVICE	X	X	X	X	X	X	X							
SWITCH HEATING, VENTILATING AND AIR-CONDITIONING EQUIPMENT CONTROLS TO FIRE-ALARM MODE	X	X	X	X	X	X	X							
RECALL ELEVATORS TO PRIMARY OR ALTERNATE RECALL FLOORS						X								
DISPLAY SUPERVISION CONDITION AT FACP			X					X	X					
TRANSMIT SUPERVISORY SIGNAL TO THE MONITORING SERVICES			X					X	X					
TRANSMIT TROUBLE SIGNAL TO THE MONITORING SERVICES										X	X	X	X	X
DISPLAY TROUBLE CONDITION AT FACP										X	X	X	X	X
RECORD EVENTS IN THE SYSTEM MEMORY	X	X	X	X	X	X	X	X	X	X	X	X	X	X
ELEVATOR SHUNT TRIP							X							

SHOP DRAWING / SUBMITTAL REVIEW

REVIEWED REVIEWED AS NOTED
 REVISE AND RESUBMIT REJECTED

Project No.: 2508 Submittal No.: 22 14 00.01

Corrections or comments made on the shop drawings during this review do not relieve the contractor from compliance with requirements of the drawings and specifications. This check is only for review of the general conformance with the design concept of the project and general compliance with the information given in the contract documents. This contractor is responsible for: confirming and correlating all quantities and dimensions; selecting fabrication processes and techniques of construction; coordinating his or her work with that and other trades and performing all in a safe and satisfactory manner.

By: *David Hammon* Date: 9/25/2025
DAMMON ENGINEERING, INC.
 Slidell, LA



REVIEWED BY:



Part No.	Qty.	Description	Standby	Total Standby	Alarm	Total Alarm
Panel Equipment						
NFW-100X_MB	1	NFW-100X_MB, Main Board	0.1410A	0.1410A	0.4000A	0.4000A
Total Panel Stby			0.1410A	0.1410A	Total Panel Alarm	0.4000A
Peripheral Devices						
NOT-BG12LX	6	PULL STATION, ADDRESSABLE (Signaling line)	0.0002A	0.0012A	0.0002A	0.0012A
NP-200	5	ADDRESSABLE PHOTO DETECTOR, B300-6 BASE INCLUDED, FLASHSCAN ONLY, WHITE (Signaling line)	0.0002A	0.0010A	0.0035A	0.0175A
NP-200R	6	REMOTE TEST CAPABLE ADDRESSABLE PHOTO DETECTOR FLASHSCAN, WHITE (Signaling line)	0.0002A	0.0012A	0.0045A	0.0270A
NC-100R	3	RELAY MODULE, ADDRESSABLE (Signaling line)	0.0003A	0.0009A	0.0051A	0.0153A
NC-100R	1	RELAY MODULE, ADDRESSABLE (Signaling line)	0.0003A	0.0003A	0.0000A	0.0000A
NP-200T	2	ADDRESSABLE PHOTO DETECTOR, B300-6 BASE INCLUDED, FLASHSCAN, WHITE, THERMAL (Signaling line)	0.0002A	0.0004A	0.0000A	0.0000A
NMM-100P	1	MINI MODULE, ADDRESSABLE (Signaling line)	0.0004A	0.0004A	0.0004A	0.0004A
SWLED	4	SWLED, Strobe, Wall, White, L-Series (Notification) 15CD	0.0000A	0.0000A	0.0180A	0.0720A
SPSWLED	5	L-Series Speaker Strobe LED, Wall, White (Notification) 95CD	0.0000A	0.0000A	0.0750A	0.3750A
SCWLED	10	STROBE, CEILING, WHITE (Notification) 15CD	0.0000A	0.0000A	0.0180A	0.1800A
SPSCWLED	7	L-Series Speaker Strobe LED, Ceiling, White (Notification) 15CD	0.0000A	0.0000A	0.0180A	0.1260A
SPSCWLED	5	L-Series Speaker Strobe LED, Ceiling, White (Notification) 75CD	0.0000A	0.0000A	0.0700A	0.3500A
SPSWLED	1	L-Series Speaker Strobe LED, Wall, White (Notification) 15CD	0.0000A	0.0000A	0.0180A	0.0180A
SPSCWLED	5	L-Series Speaker Strobe LED, Ceiling, White (Notification) 30CD	0.0000A	0.0000A	0.0220A	0.1100A
SCWLED	1	STROBE, CEILING, WHITE (Notification) 30CD	0.0000A	0.0000A	0.0220A	0.0220A
GEOL4.7K	3	Generic, EOL, 4.7K Ohms (Notification)	0.0000A	0.0000A	0.0000A	0.0000A
SWK	1	STROBE, 2 WIRE, M-C, WHITE, WALL, WP (Notification) 30CD	0.0000A	0.0000A	0.0940A	0.0940A
NC-100R	4	RELAY MODULE, ADDRESSABLE (Power)	0.0000A	0.0000A	0.0000A	0.0000A
Total Peripheral Stby			0.0053A	0.0053A	Total Periph Alarm	1.4084A
Total Standby Amps				0.1463A	Total Alarm Amps	1.8084A

Device	Part No	Appliance Desc	Distance	Current	Voltage	Voltage Drop
20.4V						
N:1	SPSCWLED	L-Series Speaker Strobe LED, Ceiling, White, 30CD	42'-6"	0.0220A	20.3231V	(0.0769V)
N:2	SCWLED	STROBE, CEILING, WHITE, 15CD	16'-0"	0.0180A	20.2956V	(0.0275V)
N:3	SPSCWLED	L-Series Speaker Strobe LED, Ceiling, White, 15CD	7'-4"	0.0180A	20.2842V	(0.0114V)
N:4	SCWLED	STROBE, CEILING, WHITE, 15CD	8'-5"	0.0180A	20.2719V	(0.0123V)
N:5	SCWLED	STROBE, CEILING, WHITE, 15CD	5'-11"	0.0180A	20.2646V	(0.0073V)
N:6	SPSCWLED	L-Series Speaker Strobe LED, Ceiling, White, 75CD	15'-1"	0.0700A	20.2442V	(0.0204V)
N:7	SPSCWLED	L-Series Speaker Strobe LED, Ceiling, White, 75CD	22'-8"	0.0700A	20.2227V	(0.0222V)
N:8	SPSCWLED	L-Series Speaker Strobe LED, Ceiling, White, 30CD	19'-3"	0.0220A	20.2095V	(0.0125V)
N:9	SPSCWLED	L-Series Speaker Strobe LED, Ceiling, White, 30CD	21'-0"	0.0220A	20.1979V	(0.0116V)
N:10	SCWLED	STROBE, CEILING, WHITE, 15CD	14'-0"	0.0180A	20.1918V	(0.0062V)
N:11	SPSCWLED	L-Series Speaker Strobe LED, Ceiling, White, 75CD	28'-7"	0.0700A	20.1827V	(0.0098V)
EOL:	GEOL4.7K	Generic, EOL, 4.7K Ohms	3'-4"	0.0000A	20.1827V	(0V)
				204'-4"	0.3660A	
Total Current: 0.3660A						
(Total VDrop Percent: 1.07%)						Total Voltage Drop : 0.218V

Part No.	Qty.	Description	Standby	Total Standby	Alarm	Total Alarm
Panel Equipment						
NFC-50/100_MB	1	NFC-50/100_MB, Main Board	0.2850A	0.2850A	2.3850A	2.3850A
Total Panel Stby			0.2850A	0.2850A	Total Panel Alarm	2.3850A
Peripheral Devices						
SPSWLED	5	L-Series Speaker Strobe LED, Wall, White (Notification) 79dB 0.5 Watts	0.0000A	0.0000A	0.0000A	0.0000A
SPSCWLED	14	L-Series Speaker Strobe LED, Ceiling, White (Notification) 76dB 0.25 Watts	0.0000A	0.0000A	0.0000A	0.0000A
SPSWLED	1	L-Series Speaker Strobe LED, Wall, White (Notification) 76dB 0.25 Watts	0.0000A	0.0000A	0.0000A	0.0000A
SPSCWLED	3	L-Series Speaker Strobe LED, Ceiling, White (Notification) 79dB 0.5 Watts	0.0000A	0.0000A	0.0000A	0.0000A
Total Peripheral Stby			0.0000A	0.0000A	Total Periph Alarm	0.0000A
Total Standby Amps			0.2850A	0.2850A	Total Alarm Amps	2.3850A

Circuit	Description	Type	Total Len	SPSWLED	SPSCWLED	Total Watts	Gauge	dB Loss	Max Allowable Len
SPK1		Notification/Audio 25v	712'-9"	6	17	7.75 Watts	#16	-0.38 dB	6653'

332 N NEW HAMPSHIRE
 SUITE 100
 SLIDELL, LA 70662
 PHONE: (504) 471-0917 FAX: (504) 471-0924
 50 VETERANS BLVD. KENNER, LA, 70062, PH. (504) 471-0917, FAX (504) 471-0924

DRAWN BY: W. GUILLOT DATE: 09/19/2025
 APPROVED BY: W. LEVET DATE: 09/19/2025
 PROJECT NUMBER:
ADS# 6390
 SCALE: N.T.S.
 SHEET TITLE:
 RISER & SEQUENCE OF OPERATION & BATTERY CALCS
 SHEET NUMBER:
FA-03
 02 OF 02