

K-1035, K-1036

FEATURES

- 54" x 44-1/4" x 13"
- Acrylic
- 2 hp variable flow pump, integral heater and suction housing
- Outlet at left or right
- Recirculating pump delivers flows up to 80 gallons per minute of powerful hydro-massage
- Order one Tower, Bath/Footbath, and Enclosure for each complete BodySpa installation

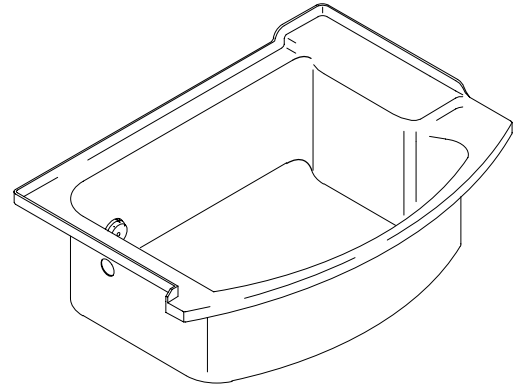

CODES/STANDARDS APPLICABLE

Specified model meets or exceeds the following:

- ANSI Z124.1
- ASME/ANSI A112.19.7M
- IAPMO/UPC
- Underwriters Laboratories (UL)

COLORS/FINISHES

- 0 White
- Other Refer to Fixtures Price Book for additional colors

Accessories:

- CP Polished Chrome
- PB Polished Brass
- SS Satin Silver
- SB Satin Brass
- Other Refer to Faucets Price Book for additional finishes

SPECIFIED MODEL:

Model	Description	Colors/Finishes	
K-1035	Footbath with outlet at left	<input type="checkbox"/> 0 White	<input type="checkbox"/> Other _____
K-1036	Footbath with outlet at right	<input type="checkbox"/> 0 White	<input type="checkbox"/> Other _____

Required Accessories				
K-1030	BodySpa 8-Jet Tower	<input type="checkbox"/> CP	<input type="checkbox"/> PB	<input type="checkbox"/> Other _____
K-5161-L	Alcove enclosure (shower doors)	<input type="checkbox"/> SS	<input type="checkbox"/> SB	<input type="checkbox"/> 0 White
Recommended Accessories				
K-7160-TF	Drain	<input type="checkbox"/> CP	<input type="checkbox"/> PB	
K-1099	Taboret Rite-Temp OR	<input type="checkbox"/> CP	<input type="checkbox"/> PB	
K-1098	Taboret Two-handle	<input type="checkbox"/> CP	<input type="checkbox"/> PB	

PRODUCT SPECIFICATION:

The footbath shall be 54" in length, 44-1/4" in width, and 13" in height. Footbath shall be made of acrylic. Footbath shall have 2 hp variable flow pump, integral heater and suction housing. Footbath shall have sliding seat. Footbath shall have an outlet at left or right. Footbath recirculating pump shall deliver flows up to 80 gallons per minute of powerful hydro-massage. Footbath shall be configured with BodySpa 8-Jet Tower, and BodySpa Enclosure. Footbath shall be Kohler Model K-_____ - _____.

BODYSPA

REQUIRED ELECTRICAL SERVICE

Dedicated circuit required, protected with Class A Ground-Fault Circuit-Interrupter (GFCI):	
Pump/control	120 V., 20 A, 60 Hz

PRODUCT INFORMATION

Fixture*:	basin area	top area	weight	
Bathing well	44" x 36"	45" x 37"	110 lbs.	
	water depth	capacity		
To overflow	8-1/4"	43 gal.**		
* Approximate measurements for comparison only.				
** 37 gallon minimum required for BodySpa operation.				
Pump:	HP	V	Hz	A
1-speed	2	120	60	18.5

INSTALLATION NOTES

Locate control switch within the boundaries of the enclosure. 6' cable is included.

Allow 83-1/2" to 84" from sub-floor to finished ceiling or header for proper enclosure installation.

Top of unit must be enclosed to retain heat and contain water spray.

Pump is supplied with a grounding type plug-in cord. Locate the outlet behind the whirlpool, and within 24" of the pump.

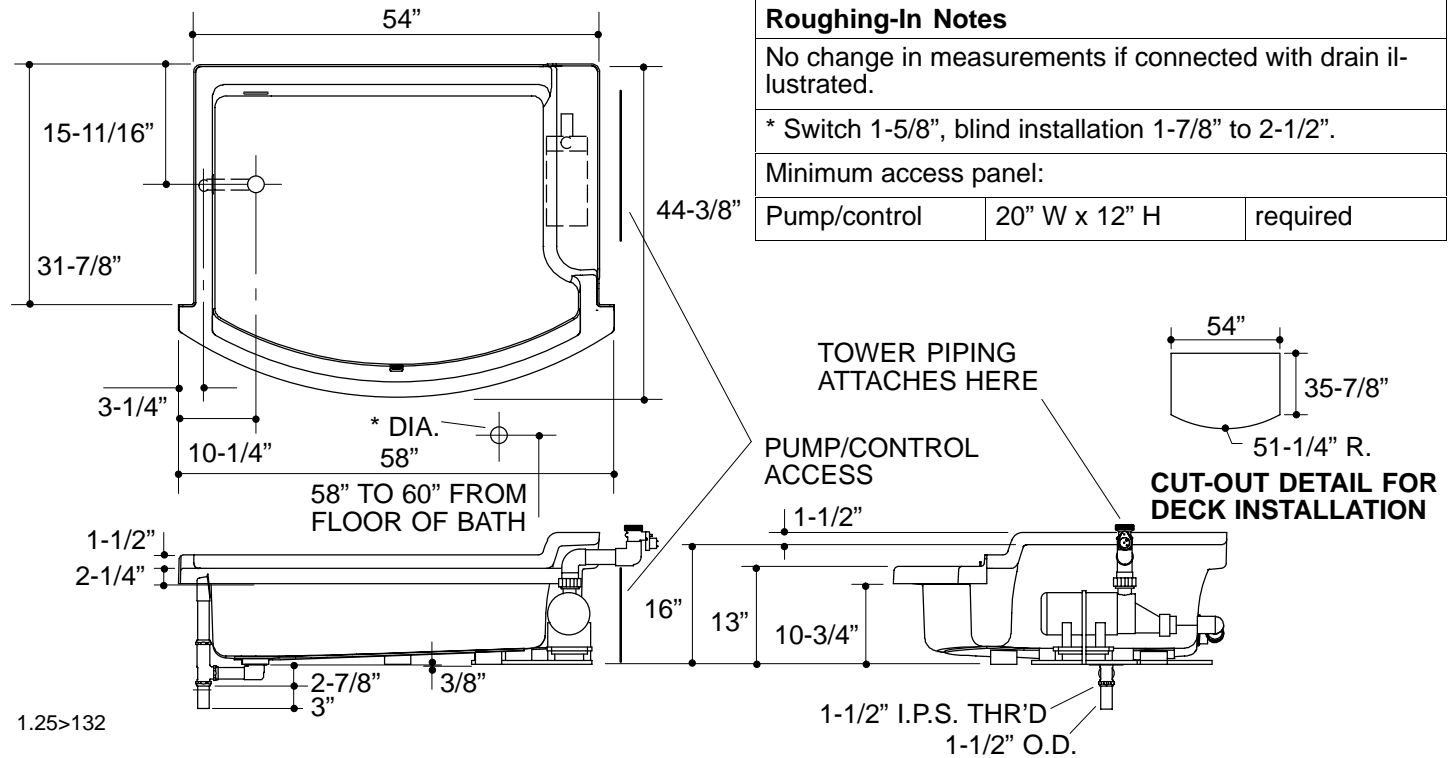

PRODUCT DIAGRAM