

### SELF-RIMMING KITCHEN SINK

# K-5850

#### FEATURES

- 43" x 22"
- Cast iron
- Acid resistant enamel finish
- Self-rimming
- Double (equal) compartment
- 3-hole (K-5850-3), or single-hole (K-5850-1) drilling

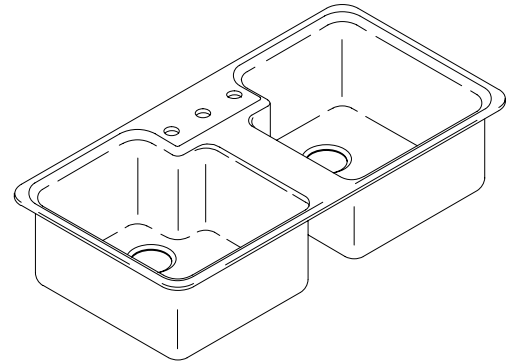

#### CODES/STANDARDS APPLICABLE

Specified model meets or exceeds the following:

- ASME/ANSI A112.19.1M
- IAPMO/UPC
- Canadian Standards Association (CSA)
- State of Massachusetts

#### COLORS/FINISHES

- 0 White
- Other Refer to Fixtures Price Book for additional colors

#### Accessories:

- CP Polished Chrome
- 0 White
- NA None Applicable
- Other Refer to Price Book for additional colors

#### SPECIFIED MODEL:

Model	Description	Colors/Finishes	
K-5850-3	3-hole sink	<input type="checkbox"/> 0 White	<input type="checkbox"/> Other_____
K-5850-1	Single-hole sink	<input type="checkbox"/> 0 White	<input type="checkbox"/> Other_____

Recommended Accessories			
K-9000	Trap	<input type="checkbox"/> CP	
Optional Accessories			
K-5859	Saddle cover and polypropylene colander	<input type="checkbox"/> 0 White	
K-5917	Cutting board	<input type="checkbox"/> NA	
K-8801	Duostrainer sink strainer	<input type="checkbox"/> CP	<input type="checkbox"/> Other_____

#### PRODUCT SPECIFICATION:

The self-rimming sink shall be 43" in length, and 22" in width. Sink shall be made of cast iron with acid resistant enamel finish. Sink shall be double (equal) compartment. Sink shall be 3-hole (K-5850-3), or single-hole (K-5850-1) drilled. Sink shall be Kohler Model K-5850-\_\_\_\_\_ -\_\_\_\_\_.

## PRODUCT INFORMATION

Fixture*:		basin area	water depth
Sinks		17" x 19"	9"
Outlet	3-5/8" D.		
Faucet holes	1-3/8" D.		

\* Approximate measurements for comparison only.

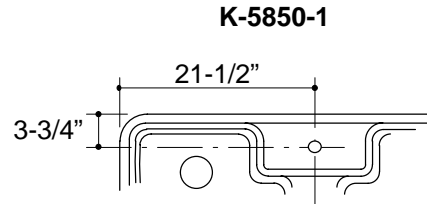
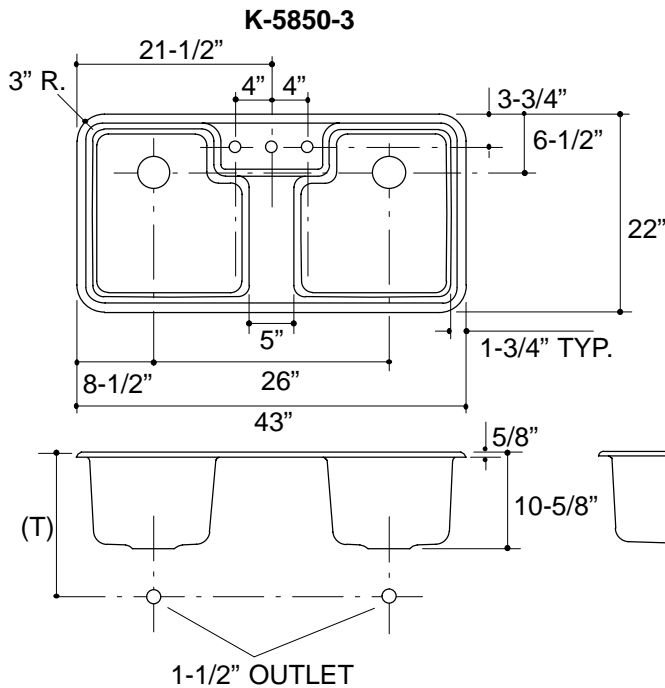

### Roughing-In Notes

Fixture dimensions are nominal and conform to tolerances in AMSE/ANSI Standard A112.19.1M.

(T) Drain typically 16".

Cutout 41-3/4" x 20-3/4" with 2-1/4" radius corners.

.75<116

## PRODUCT DIAGRAM