

### FEATURES

- 60-1/2" x 60-1/2" x 24"
- Acrylic
- System II - 1 hp 2 speed pump with integral heater & electronic switch
- 6 Flexjets
- UL Listed
- LESS ALL TRIM
- For corner installation
- Optional K-1435 front apron
- Pump is supplied with a grounding-type plug-in cord

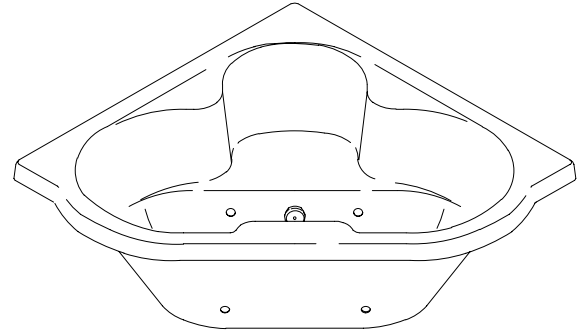

### CODES/STANDARDS APPLICABLE

Specified model meets or exceeds the following:

- ANSI Z124.1
- ASME/ANSI A112.19.7M
- IAPMO/UPC
- Underwriters Laboratories (UL)
- State of Massachusetts
- City of Los Angeles, CA

### COLORS/FINISHES

- 0 White
- Other Refer to Fixtures Price Book for additional colors

#### Accessories:

- CP Polished Chrome
- PB Polished Brass
- Other Refer to Faucets Price Book for additional finishes
- NA None Applicable

### SPECIFIED MODEL:

Model	Description	Colors/Finishes		
K-1433-H	Corner bath whirlpool	<input type="checkbox"/> 0 White	<input type="checkbox"/> Other_____	
<b>Required Accessories</b>				
K-9696	Jet trim kit	<input type="checkbox"/> CP	<input type="checkbox"/> PB	<input type="checkbox"/> Other_____
<b>Recommended Accessories</b>				
K-7167	Drain	<input type="checkbox"/> CP	<input type="checkbox"/> PB	<input type="checkbox"/> Other_____
<b>Optional Accessories</b>				
K-1435	Apron (removable)	<input type="checkbox"/> 0 White	<input type="checkbox"/> Other_____	
K-1181	Vinyl tiling-in bead (use when wall material contacts any top surface of bath)	<input type="checkbox"/> NA		

### PRODUCT SPECIFICATION:

The bath whirlpool shall be 60-1/2" in length, 60-1/2" in width, and 24" in height. Bath whirlpool shall be made of acrylic. Bath whirlpool shall have System II, with 6 Flexjets, 1 hp 2-speed pump with integral heater, and electronic switch. Bath whirlpool shall be UL listed. Bath whirlpool shall be less all trim. Bath whirlpool shall be for corner installation. Bath whirlpool shall have optional K-1435 front apron. Bath whirlpool pump shall be supplied with a grounding-type plug-in cord. Bath whirlpool shall be Kohler Model K-1433-H-\_\_\_\_\_.

# CORNERSTONE™

## REQUIRED ELECTRICAL SERVICE

Dedicated circuit required, protected with Class A Ground-Fault Circuit-Interrupter (GFCI):	
Pump/control, heater	120 V., 20 A, 60 Hz

## PRODUCT INFORMATION

Fixture*:	basin area	top area	weight		
Bathing well	45" x 25"	66" x 33"	155 lbs.		
	water depth	capacity			
To overflow	19"	112 gal.			
* Approximate measurements for comparison only.					
Pump	high HP	low HP	V	Hz	A
2-speed	1	1/8	120	60	16.5
Included Components:					
Cutout template	111461-7				

## INSTALLATION NOTES

If installing a rim-mount faucet, make sure there is no interference with drain overflow and circulating system before drilling any holes. Consult local and national codes for minimum air gap requirements if installing a spout on the faucet deck.

Each pump is supplied with a grounding type plug-in cord. Locate the outlet behind the whirlpool, and within 24" of the pump.

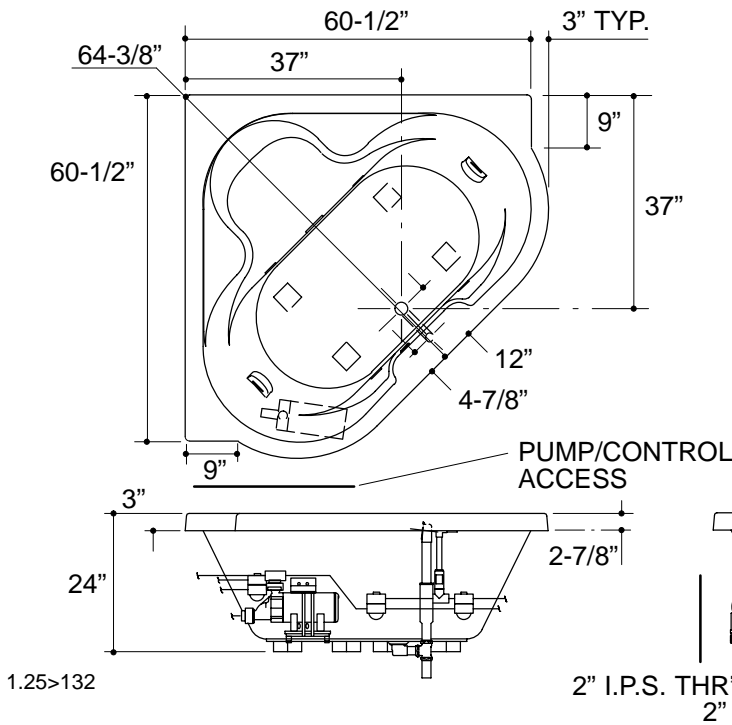

### Roughing-In Notes

No change in measurements if connected with drain illustrated.

Cut-out	59" x 59" corner installation. Unit must be on job site to determine cut-out radius of contoured front.
---------	---

Minimum access panel:

Pump/control	20" W x 15" H	required
--------------	---------------	----------

## PRODUCT DIAGRAM