

Ordering Information

Accessories/hardware:		
Jet trim kit	K-9661	required
Drain	K-7167	recommended

Required Electrical Service

Two separate dedicated circuits required, each protected with Class A Ground-Fault Circuit-Interrupter (GFCI):

Pump/control, (waterfall)	120 V., 20 A, 60 Hz
Pump/control, (jets)	120 V., 20 A, 60 Hz

Product Information

Fixture*:	basin area	top area	weight	
Bathing well	61" x 46"	68" x 58"	240 lbs.	
	water depth	capacity		
To overflow	20"	215 gal.		
* Approximate measurements for comparison only.				
Pump: (Qty. 2)	HP	V	Hz	A
1-speed	2	120	60	18.5
Included Components:				
Cutout template			85899-7	

Installation Notes

Refer to installation instructions included with fixture before beginning installation.

NOTICE: The floor must support 3,000 pounds.

Pumps are supplied with grounding-type plug-in cords. Locate the outlets behind the RiverBath, and within 24" of the pumps.

If installing a rim-mount faucet, make sure there is no interference with drain overflow and circulating system before drilling any holes. Consult local and national codes for minimum air gap requirements if installing a spout on the faucet deck other than that supplied.

Two 60 gallon (120 gallon total) water heaters are necessary to fill RiverBath.

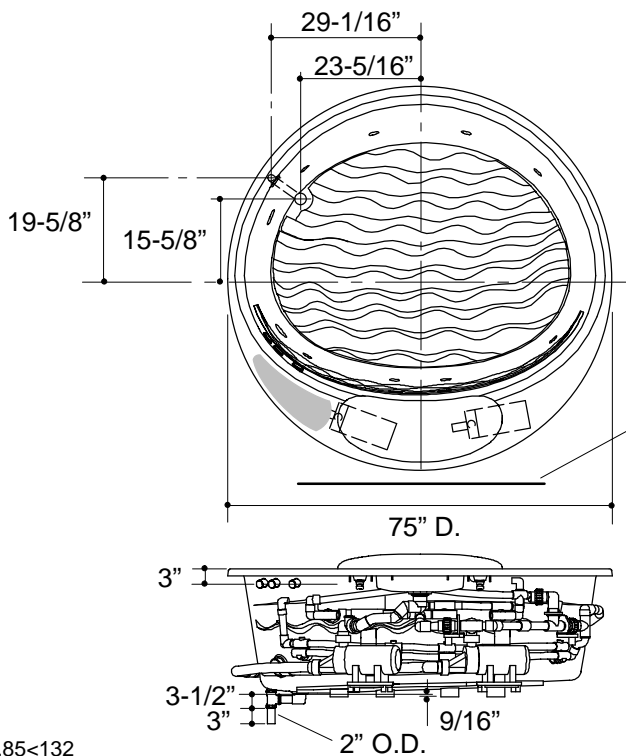

Roughing-In Notes		
Fixture conforms to ANSI Standard Z124.1. All dimensions are nominal.		
No change in measurements if connected with drain illustrated.		
Faucet area		recommended
Minimum access panel:		
Pump/control	48" W x 18" H	required

PUMP/CONTROL ACCESS

