

LIGHTING FIXTURE SCHEDULE			
SYMBOL	DESCRIPTION	SYMBOL	DESCRIPTION
(R)	RECESSED FIXTURE	-----	FLUORESCENT STRIP FIXTURE
(E)	EXTERIOR RECESSED FIXTURE	▭	48" 2-LAMP FLUORESCENT FIXTURE
(W)	WATERPROOF RECESSED FIXTURE		
(S)	WALL SCONCE - ELECTRIC	⊕	CEILING FAN, WITHOUT LIGHT KIT
(P)	PENDANT FIXTURE		
(U)	UPLIGHT AT EXTERIOR		
(V)	HEAT, VENT, LIGHT	⊙	SPOTLIGHTS

MEP SYMBOLS			
SYMBOL	DESCRIPTION	SYMBOL	DESCRIPTION
⊞	SINGLE SWITCH, 42" A.F.F.	⊞220	220 V OUTLET
⊞	SINGLE SWITCH, 42" A.F.F., AUTO. TURN ON W/ DOOR	⊞GFI	GROUND FAULT INTERRUPTED OUTLET, WEATHER PROOF
⊞	3-WAY SWITCH, 42" A.F.F.	⊞HB	HOSE BIB
⊞	4-WAY SWITCH, 42" A.F.F.	⊞C	CABLE OUTLET, 18" A.F.F.
⊞	DIMMER SWITCH, 42" A.F.F.	⊞T	TELEPHONE, 18" A.F.F.
⊞	AUTOMATIC DOOR SWITCH	⊞S	SMOKE DETECTOR
⊞	DUPLEX OUTLET, 18" A.F.F.	⊞	THERMOSTAT
⊞	DUPLEX OUTLET, DIST. A.F.F.		
⊞	GROUND FAULT INTERRUPTED OUTLET, DIST. A.F.F.		
⊞	GAS LOCATION		

- ELECTRICAL NOTES:
1. ALL WORK SHALL CONFORM TO THE LATEST EDITION OF THE NATIONAL ELECTRICAL CODE, THE GOVERNING ELECTRICAL CODE AND ALL OTHER INSPECTION DEPARTMENTS HAVING JURISDICTION. OBTAIN CERTIFICATES OR APPROVAL WHERE REQUIRED.
  2. ALL MATERIALS FURNISHED SHALL BE NEW AND SHALL BE U.L. LISTED.
  3. PERFORM TEST REQUIRED BY THE OWNER OR THE ENGINEER IN CONNECTION WITH THE OPERATION OF THE ELECTRICAL SYSTEM IN THE BUILDING. ALL TESTS SHALL BE MADE IN ACCORDANCE WITH THE LATEST STANDARD OF THE IEEE AND THE NATIONAL ELECTRICAL CODE.
  4. MINIMUM CONDUCTOR SIZE SHALL BE #12, 600V INSULATION. MINIMUM SIZE CONDUIT SHALL BE 3/4" ELECTRICAL METALLIC TUBING (EMT) FOR INTERIOR USE, 3/4" SCHEDULE 80 FOR EXTERIOR USE ABOVE GRADE, AND 1" SCHEDULE 40 PVC BURIED A MINIMUM OF 18" FOR NON-VEHICULAR TRAFFIC AREAS FOR CONDUITS BELOW GRADE. EMT SHALL BE USED WITH METAL STUD CONSTRUCTION, USE NMC IN WOOD CONSTRUCTION. 6 FT LENGTH MC CABLE IS ALLOWED ABOVE DROPPED CEILING. INTERIOR FITTINGS SHALL BE CAST WHERE EXPOSED ON WALLS, AND EXTERIOR FITTINGS SHALL BE CAST BOXES WITH NEMA 3R COVERS).
  5. ALL 120V RUNS LONGER THAN 60 FEET SHALL BE #10 AWG AND 277V RUNS LONGER THAN 150 FEET SHALL BE #10 AWG UNLESS NOTED OTHERWISE.
  6. INSTALL GROUND FAULT RECEPTACLES AT RECEPTACLE LOCATIONS WITHIN 5' OF SINKS OR LAVATORIES, AND AT EXTERIOR LOCATIONS. EXTERIOR RECEPTACLES SHALL ALSO BE WATERPROOF.
  7. BONDING AND GROUNDING SHALL BE IN ACCORDANCE WITH NFPA 70:230-63, NFPR 250-23, 250-71 & 250-72.
  8. GROUND NEUTRAL IN ACCORDANCE WITH NFPA 70:250-23b.

PANEL "LP"  
120/240 1P 3W 125A MCB N-3R SURFACE MOUNT 10KAIC

Circuit No.	Description	Conductor Size	Volt-Amps A	Volt-Amps C	Breaker Size	Breaker Size	Volt-Amps A	Volt-Amps C	Conductor Size	Description	Circuit No.
1	HVL IN BATHROOM	#12	1800		1P 20A	1P 20A	1000		#12	CEILING FAN, OFFICE LIGHTING	2
3	EXTERIOR FLOODS & PORTE' COCHERE	#12		1000	1P 20A	1P 20A		750	#12	BATHROOM SCONCE, CLOSET LIGHTS	4
5	REAR W/P. BATH GFI, CLOSET RECEPTACLES	#12	900		1P 20A	1P 20A		720	#12	OFFICE RECEPTACLES	6
7	COUNTER TOP REC., EXT. FRONT W/P GFI	#12		360	1P 20A	1P 20A		360	#12	COUNTER TOP REC., EXT. FRONT W/P GFI	8
9	PTAC UNIT (XX)	#10		2880	2P 30A	1P 20A		120	#12	EMERGENCY AND EXIT LIGHTS	10
11				2880						SPACE	12
	(XX) SIZE BREAKER TO MATCH UNIT INSTALLED.	PHASE	5580	4240		PHASE	1840	1110			
						PH.TOTAL	7420	5350			
						TOTAL VA		12770			

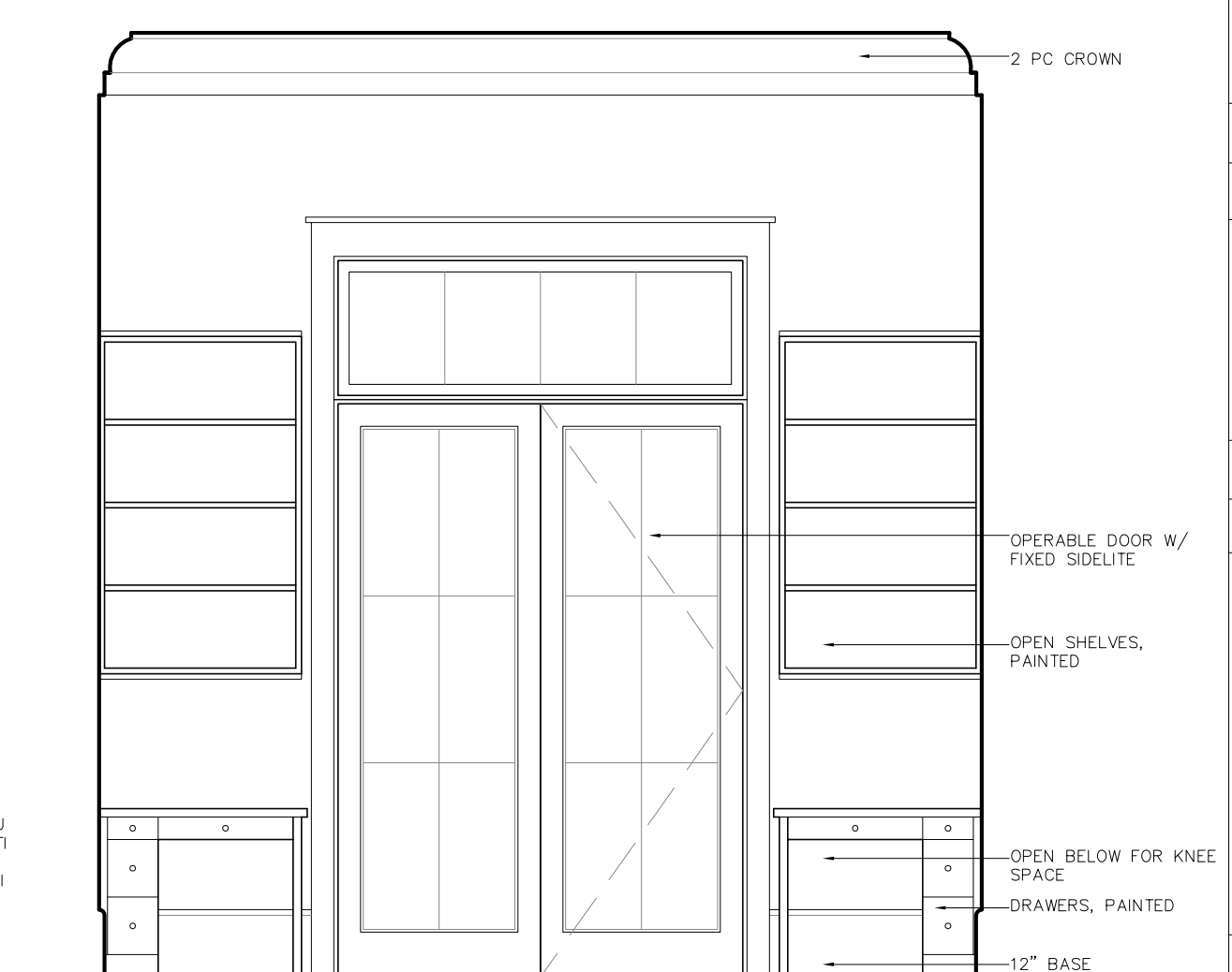
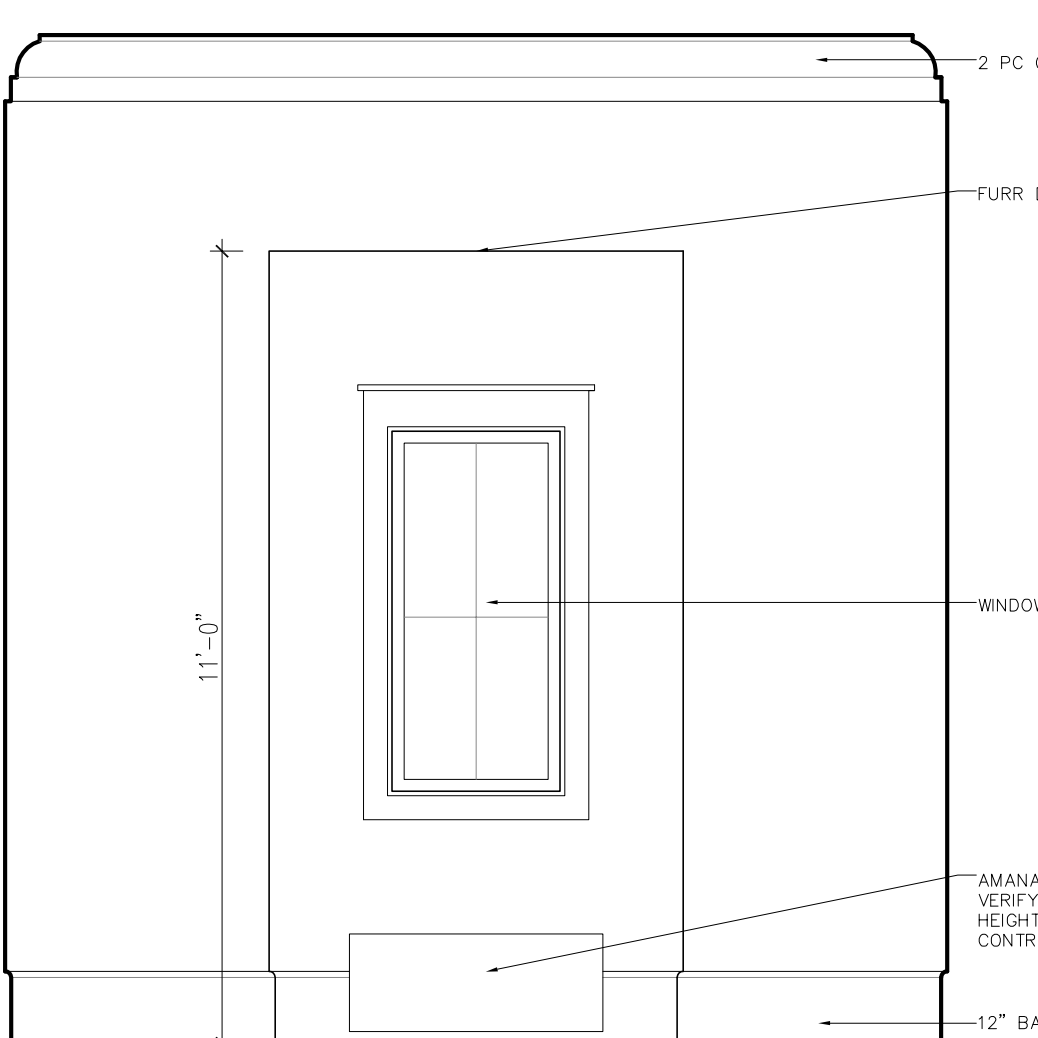
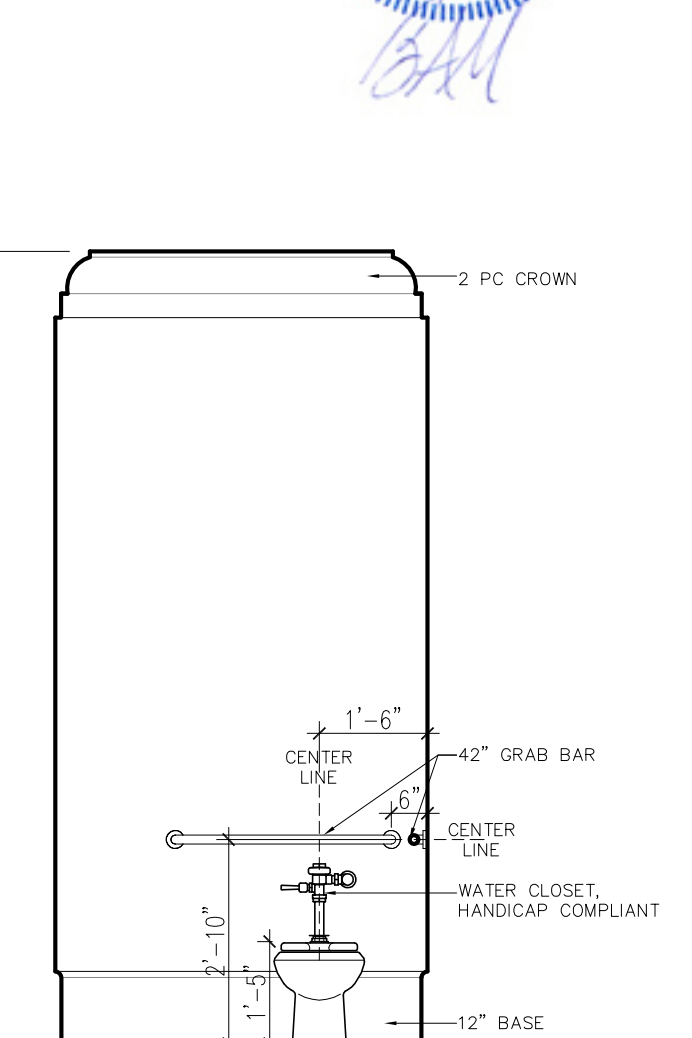
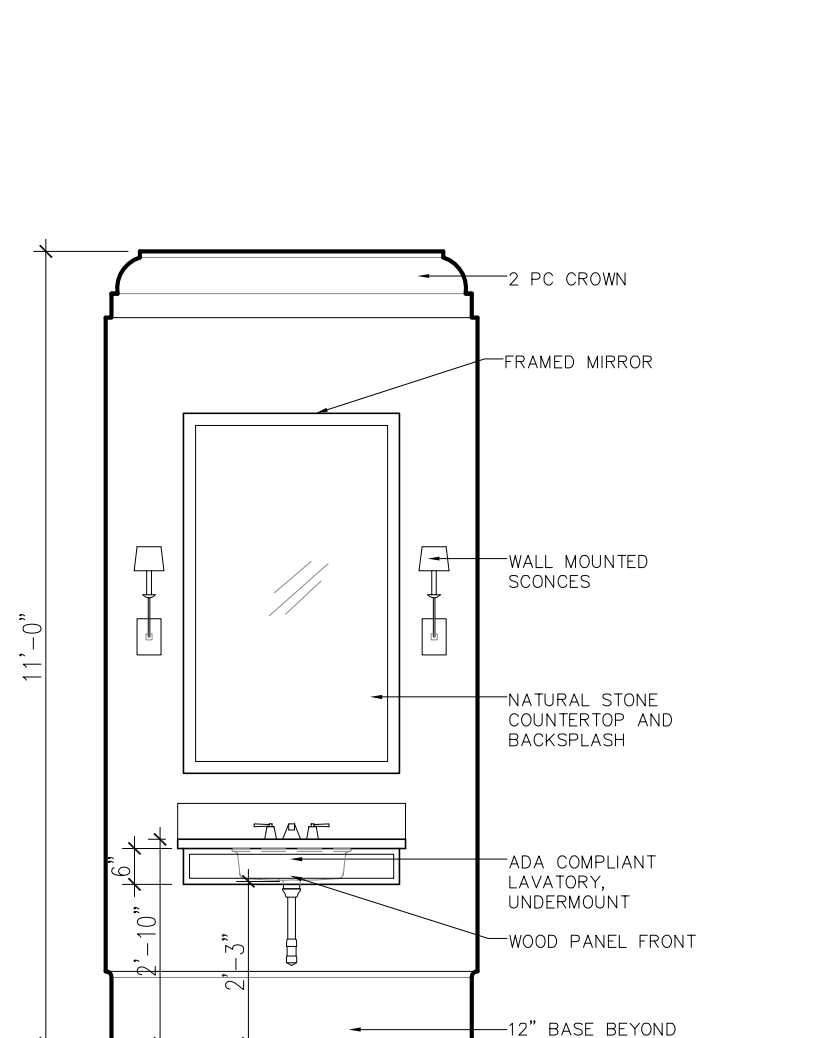

Project No.	
Date	June 16, 2015
Revised	June 25, 2015 October 20, 2015 March 22, 2016
Drawn by	JMW
Scale	as noted
Sheet Title	Lighting/ Interiors
Sheet No.	

BEAU CHENE

© 2007 studioMV, L.L.C. - These drawings are the sole property of studioMV, L.L.C. and are issued as instruments of service. These drawings shall not be copied, reproduced or used in any manner than was originally intended without consent of Matthew C. Voelkel. These drawings have been prepared under my direct supervision and to the best of my knowledge comply with the International Building Code

studioMV

A4



BEAU CHENE  
main entry gates  
covington  
ST. TAMMANY PARISH