

1

DETAIL

SCALE: 3/4"=1'-0"

SEATING PLATFORM FRAMING

NOTE:
POUR STOPS SHALL BE THE TYPE REQUIRED BY THE STEEL DECK INSTITUTE & SHALL HAVE A 1/2" VERTICAL LEG RETURN LIP.

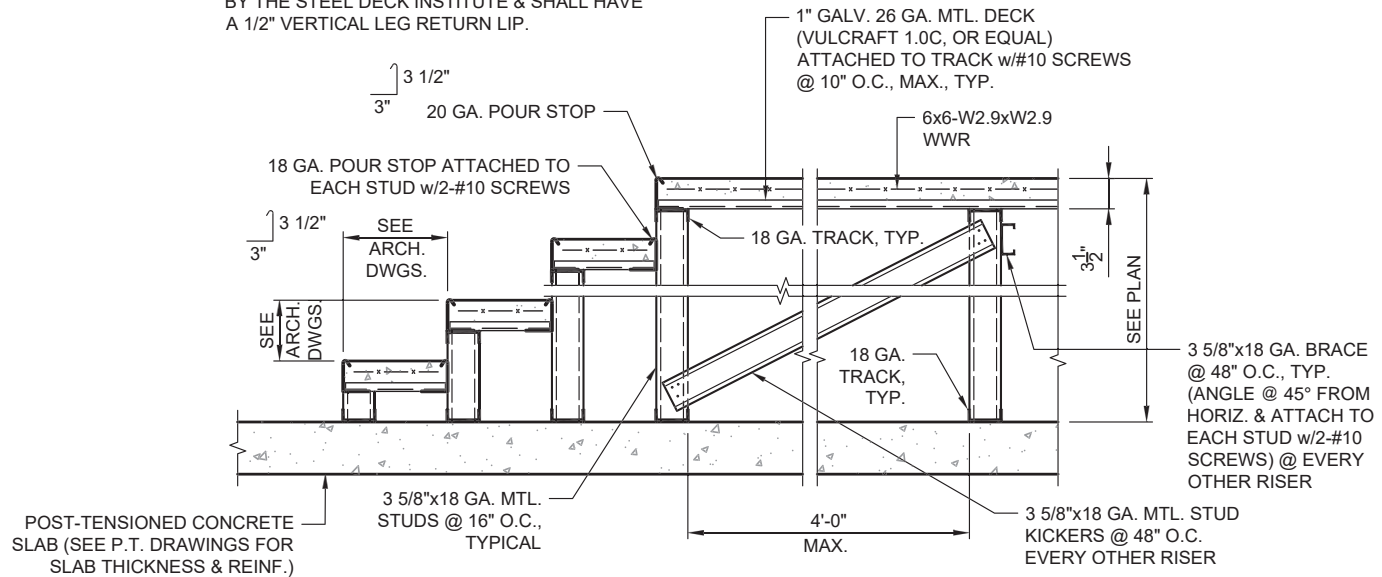

2

DETAIL

SCALE: 3/4"=1'-0"

PLATFORM FRAMING