

Permit Application

(Complete All Applicable Pages)

Project:	Elks Lodge #2321		
Project Type:	SEWAGE SYSTEM		
Estimated Project Cost:	80K		
Engineer:	BRIAN MISTICH		
Telephone:	905-285-4564		
Parish:	St Tammany	Nearest Town:	Sldell
Population Served:	270 PERSONS		
New Svstem?		Existing System?	
		to be condemned <input checked="" type="checkbox"/>	
Project to be Owned and Operated By: <small>(include name and address)</small>	Sldell Elks' Lodge # 2321 34212 Elk's Rd Sldell LA 70460		
Proposed Project Will Connect to: <small>(name of water and/or sewer system)</small>	N/A		



SEWER COLLECTION SYSTEM

Project:		ELKS LODGE #2321			
Engineer:		Brian A. Mistich			
General Scope of Project:		Sewage Treatment Plant			
GRAVITY PIPING	Material (specify ASTM standard and standard dimension ratio-SDR)	ASTM D3034, SDR 35			
	Size (8 inch minimum diameter)	4"			
	Joints and Materials of Fitting:	Glue Joints			
FORCE MAINS	Material (specify ASTM standard and standard dimension ration-SDR)	n/a			
	Size (3 inch minimum diameter <u>without</u> grinder pumps; 1 ¼ minimum diameter <u>with</u> grinder pumps)	n/a			
	Joints and Materials of Fitting:	n/a			
LAYOUT	Slope of Gravity Mains	1%Min.	1%Max.	1%Majority	
	Location with Respect to Water Lines:	Maintain 18" Minimum Vertical Clearance @ Crossings?	<input checked="" type="checkbox"/> Yes <input type="checkbox"/> No		
		Maintain 6' Minimum Horizontal Clearance?	<input checked="" type="checkbox"/> Yes <input type="checkbox"/> No		
	Maximum Distance Between Manholes:	n/a			
	Number of Surface Water Crossings/Encounters:	n/a			
	Other Comments: (Manhole Construction, Highway Crossing, etc.)				
Deflection Testing?		Hydrostatic Testing?			
<input type="checkbox"/> Yes <input type="checkbox"/> No		<input type="checkbox"/> Yes <input type="checkbox"/> No			
NAME OF CERTIFIED OPERATOR:		GRETCHEN LANDRY #57072			

EXTENDED AERATION SEWAGE TREATMENT FACILITY

1 of 3

Project:	Elks' Lodge #2321			Water Well within 100'?
Engineer:				
General Scope of Project:	Sewer treatment plant by EJ Breaux Contractors LLC			
				<input type="checkbox"/> Yes <input checked="" type="checkbox"/> No
Design Average Flow:	<i>5000 GPD</i>			
BOD ₅ Loading (in lbs of BOD ₅ per day):				
Max. # of Lots or Population at Maximum Capacity:				
Initial # of Lots (or population):				
Industrial Waste:	N/A			
Design Effluent Limits:	BOD ₅ : 24 mg/L MO AVG	TSS: 30 mg/L MO AVG	NH ₃ N: 05	
RECEIVING STREAM: (provide complete path from outfall to first perennial non-intermittent waterway in the path of the projected outfall.)	Parish drainage ditch Bayou Liberty			
Plant Manufacturer:	EJ Breaux Contractors, LLC			
Plant Model #:	EJBC5.0			
Materials of Construction:	Concrete			
AERATION TANK	Volume:	5,000 gallons		
	Retention Time (24 Hour Min):	24		
	BOD ₅ Loading: (lb per 1000 CF, 12.5 max.)	8.35		
	Screen or Communitor?	<input type="checkbox"/> Yes <input checked="" type="checkbox"/> No		
FINAL CLARIFIER	Surface Area:	35.65		
	Surface Loading: (extended aeration plants 1000 gpd/ft ² @ peak hourly flow max loading)	137		
	Volume:	840		
	Scum Baffle:	Yes		
	Skimmer Through:	Yes		
	Weir Length (ft):	5'6"		
	Weir Loading: (at peak hourly flow Plant ≤ 1mgd has 20,000 gpd/ft max load Plant > 1mgd has 30,000 gpd/ft max load)	455		
NAME OF CERTIFIED OPERATOR:	<i>GRETCHEN CANDRY</i> <i>#57072</i>			

EXTENDED AERATION SEWAGE TREATMENT FACILITY

2 of 3

AIR SUPPLY	# of Blowers (2 minimum):	2		
	Capacity of Each (SCFM):	36		
SLUDGE RETURN	Method:	Air Lift		
	Maximum Flow (GPM):	5.2 GPM		
	Maximum Percent (% of DAF):	150%		
SLUDGE DRYING BEDS	Number of Beds:	N/A		
	Area of Each Bed:	N/A		
	Total Area:	N/A		
	Area per Capita:	N/A		
	Gravel Layer Depth:	N/A		
	Sizes:	N/A		
	Sand Depth:	N/A		
	Under-drain Size:	N/A		
	Freeboard Above Sand:	N/A	Splash Plate? <input type="checkbox"/> Yes <input type="checkbox"/> No	
	Effluent To:	N/A		
SLUDGE LAGOONS	Number of Lagoons:	N/A		
	Maximum Depth:	N/A		
	Free Board:	N/A		
	Volume of Each Lagoon:	N/A		
	Volume of Each Lagoon per Capita:	N/A		
	Pump:	N/A		
	Piping Material:	N/A	Size: N/A	
	Effluent To:	N/A		
OTHER SLUDGE DISPOSAL METHODS Explain:	Will haul off as needed according to state law.			

EXTENDED AERATION SEWAGE TREATMENT FACILITY

3 of 3

CHLORINATION	Number:		2		
	Gas or Hypo:		hypo		
	Capacity (lb per 24 hrs):		.33		
	Test Kit:		Not applicable		
	Location:		inline		
	Ventilation:		open grating top		
CHLORINE CONTACT CHAMBER	Inside Dimensions	Length:	60"		
		Width:	36"		
		Operating Depth:	20"		
	Capacity (gal):		220		
	Retention Time: (15 minute minimum @ peak hourly flow or maximum rate of pumping)		32 min		
	Over-and-Under or End-Around Baffles? <input type="checkbox"/> Yes <input checked="" type="checkbox"/> No			Scum Baffles? <input type="checkbox"/> Yes <input checked="" type="checkbox"/> No	
ADDITIONAL DETATILS	Power Supply (Dual)? <input type="checkbox"/> Yes <input checked="" type="checkbox"/> No		Washdown Facility? <input checked="" type="checkbox"/> Yes <input type="checkbox"/> No		
	Facility Fenced? <input checked="" type="checkbox"/> Yes <input type="checkbox"/> No		Gates Locked? <input checked="" type="checkbox"/> Yes <input type="checkbox"/> No		
		Backflow Prevention? <input checked="" type="checkbox"/> Yes <input type="checkbox"/> No Type: BWV			
		Access Road? <input type="checkbox"/> Yes <input checked="" type="checkbox"/> No			
Copy of DEQ Administrative Completeness Determination Letter and Response to Request for Preliminary Determination or Discharge Permit attached? <input checked="" type="checkbox"/> Yes <input type="checkbox"/> No					
ADDITIONAL COMMENTS					
LOCATIONAL INFORMATION	Coordinates:				
	Latitude 30° 18' 03" N				
	Longitude 89° 49' 04" W				
	OR				
	Latitude . ° N				
Longitude . ° W					
Geographic Datum: NAD83 <input type="checkbox"/> WGS84 <input type="checkbox"/> NAD27 <input type="checkbox"/>					
Collection Method: GPS <input type="checkbox"/> — DGPS/WAAS enabled? Yes <input type="checkbox"/> No <input type="checkbox"/> — Horizontal Accuracy? _____ meters Map <input type="checkbox"/> Specify: _____ Scale: _____					

EJB Commercial Systems
3153 Hwy 70 South, Pierre Part, LA 70339
Phone: 985-252-6183
email: ejbreaux@bellsouth.net

Concrete Sewage Treatment Systems

General

The wastewater treatment plant shall be an EJ Breaux Commercial Systems; model EJBC5.0 prefabricated concrete package plant as manufactured by EJ Breaux Commercial Systems, Pierre Part, Louisiana. The wastewater treatment system shall be of the activated sludge type specifically known as "extended aeration" designed for treating a total of 5,000 gallons per day of 210 PPM-BOD₅; maximum, domestic sewage based on composite sewage samples of the average daily flow. The complete system shall include all necessary equipment for the efficient plant operation.

The system shall be factory assembled so as far as possible, with all piping and controls.

Influent Characteristics

The system shall be capable of treating 5,000 gallons per day of raw domestic sewage, having a maximum organic strength of 210 PPM (BOD₅), and 210 PPM suspended solid. No substance shall be introduced in quantities, which are toxic to biological organisms. The plant shall be designed to handle average daily flow rates not to exceed 250% of the design flow.

Tank Construction

All tank vessels shall be fabricated with 4,000 PSI concrete with rebar & 6" wire mesh. All walls shall be continuous and water-tight and shall be supported by a structural reinforcing member where required.

All tank piping shall be schedule 40 galvanized steel and \ or PVC.

The system shall be transported to the job site in 4 section(s).

Influent Connection

The influent connection shall be one 4" (four inch) FNPT collar.

Aeration Chamber

There shall be an aeration chamber to work in conjunction with the clarifier chamber. The aeration chamber shall conform to the following specification: The aeration shall be of sufficient capacity to provide a minimum of 24 hours retention of the average daily flow, and/or a minimum of 5.1 cubic feet per pound of BOD₅ of applied loading. The vessel shall be so shaped on each side to prevent sludge accumulation, to enhance rotation of the vessel contents, and to prevent scum and froth accumulation.

JOHN BEL EDWARDS
GOVERNOR

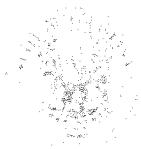

ROGER W. GINGLES
SECRETARY

State of Louisiana

DEPARTMENT OF ENVIRONMENTAL QUALITY
OFFICE OF ENVIRONMENTAL SERVICES

August 1, 2023

All American Lodge Greatest in Elkdome
34212 Elks Rd
Slidell, LA 70460

Permit Number: LAG532887
Agency Interest Number: 157925

RE: Renewal of Coverage under LPDES General Permit (LAG530000) for Discharges of Treated Sanitary Wastewater and/or Other Accepted Wastewater Types Totaling Less than 5,000 Gallons per Day

Dear Permittee:

The Louisiana Department of Environmental Quality (LDEQ) has reissued the LPDES General Permit LAG530000 permit with an effective date of December 1, 2022. Pursuant to the Louisiana Environmental Quality Act (La R.S. 30:2001 et seq), authorization under the Permit, is hereby extended to

All American Lodge Greatest in Elkdome
34212 Elks Rd
Slidell, LA

to discharge treated sanitary wastewater (less than 5,000 GPD) from your facility into subsegment 040905. If circumstances at the permitted facility are expected to change in the future and the change will result in the addition or elimination of permitted outfalls, or a change in the composition of effluent from a permitted outfall, the permittee is required to notify the Water Permits Division of the proposed changes and to receive the appropriate permit coverage prior to adding a new outfall or changing the composition of effluent from a permitted outfall. This reissued permit will replace and cancel the prior version of the permit which was previously issued to your facility. Please note that your permit number will remain the same. **To ensure that all correspondence regarding this facility is properly filed into the LDEQ's Electronic Document Management System (EDMS), you must reference your Agency Interest Number AI 157925 and LPDES general permit authorization number LAG532887 on all future correspondence to LDEQ.**

The permittee shall follow the Effluent Limitations and Monitoring Requirements established in **Appendix A**, which is attached to this permit. Appendix A is facility specific and details which schedule(s) from Part I of the permit apply to the facility. Please note that any schedule in Part I of the permit that is **NOT** listed in Appendix A shall **NOT APPLY** to this particular facility.

Please review the Effluent Limitations and Monitoring Requirements in Appendix A. If there is an error, please contact the Water Permits Division for assistance.

Pursuant to LAC 33:IX.2701.L.4.a, monitoring results shall be reported to the Enforcement Division through a department-approved electronic document receiving system (NetDMR). Paper DMRs or an alternative substitute may only be utilized by the permittee if the LDEQ Enforcement Division grants a written authorization to the permittee. See the enclosed NetDMR information sheet.

Your facility will be assessed an Annual Maintenance and Surveillance Fee to be invoiced separately by the LDEQ. Annual fee amounts are subject to adjustment at a later date by promulgation of changes in the Louisiana Administrative Code (LAC). Pursuant to LAC 33:IX.1309.I, LAC 33:IX.6509.A.1 and LAC 33:I.1701, you must pay any outstanding fees to the LDEQ. Therefore, please verify your facility's fee status by contacting LDEQ's Office of Management and Finance, Financial Services Division at (225) 219-3863. Any outstanding fees must be remitted via a check to the LDEQ within thirty (30) days after the effective date of your permit. Failure to pay the full amount due in the manner and time prescribed could result in applicable enforcement actions as prescribed in the Environmental Quality Act, including, but not limited to revocation or suspension of the applicable permit, and/or a civil penalty against you.

A copy of the permit can be accessed and printed from LDEQ's Internet website at <http://www.deq.louisiana.gov> using the following path: WATER – Permits – LPDES Permit Information – LAG530000 or by entering the Document ID 13545668 in LDEQ's Electronic Document Management System (EDMS) search window found at <http://edms.deq.louisiana.gov/app/doc/quervdef.aspx>. In the event you are unable to access and/or print a copy of this permit for your records from one of the above listed sources, please contact the Water Permits Division at (225) 219-3590 to request a hard copy be sent by mail. In compliance with LAC 33:IX.2701.H, the permittee may be required to provide a copy of the permit at the request of the administrative authority. Please read the entire permit very carefully to ensure that you thoroughly understand the conditions of the permit.

For all sanitary treatment plants, the plans and specifications must be approved by the Department of Health, Office of Public Health, P.O. Box 629, Baton Rouge, Louisiana 70821-0629, (225) 342-8093.

Please be advised that according to LA R.S. 48:385, any direct discharge to a state highway ditch, cross ditch, or right-of-way shall require approval from the Louisiana Department of Transportation and Development, P.O. Box 94245, Baton Rouge, Louisiana 70804, (225) 379-1927, and from the Department of Health, Office of Public Health, P.O. Box 629, Baton Rouge, Louisiana 70821-0629, (225) 342-8093.

Should you have any questions concerning the general permit, please feel free to contact Laura Thompson at (225) 219-0803 or Rachel Davis at (225) 219-3515.

Sincerely,



Kimberly Corts, Manager
General and Municipal Permit Section

Attachments: Appendix A and NetDMR Information

cc: IO-W

To insure maximum retention and eliminate short circuiting of raw sewage particle, the aeration chamber shall be constructed with air diffusers placed longitudinally along one side of the chamber so as to, in conjunction with the flow control baffles, enhance the spiral rotation of the chamber content. To insure adequate circulation velocity the proportion of chamber width to depth, in the direction of rotation of the chamber content, shall not exceed 1.33 to 1. The velocity of rotation shall be sufficient to scour the bottom and prevent sludge filleting as well as to prevent the escape to the surface of minuscule air diffusion bubbles and so causing their entrapment to provide maximum oxygenation efficiency. An air distribution manifold shall be installed longitudinally on one side of the tank with diffuser drop assemblies connected there to. Each diffuser drop assembly shall be equipped with an air regulating and/or shutoff valve, a disconnecting union and a diffuser bar with air diffuser nozzles minimum air velocity shall be maintained to insure efficient velocity of self cleaning. The diffusers shall be parallel to, and near the base of the vessel side wall, and at an elevation which will provide the optimum diffusion and mixing of the vessel content. The oxygen transfer capacity detailed in the aeration chamber will be designed to meet treatment requirements of the design sewage load.

Clarifier Chamber

There shall be a clarifier chamber to work in conjunction with the aeration chamber of that system. The clarifier shall conform to the following specification: The clarifier chamber shall be of such as to provide a minimum of four hours retention, based upon the same design flow rate governing the aeration chamber, but including adjustment of such rate to compensate for run-off period, and shall have proper baffling to prevent short circuiting and to provide maximum uniform solids settling areas.

The bottom of the chamber wall shall be formed into an inverted pyramidal hopper or hoppers. The flat bottom area of each hopper shall not exceed one square foot. The slope of the hopper walls shall not be less than 1.7 vertical to 1.0 horizontal. Settled sludge shall be returned from the clarifier sludge hopper to the aeration chamber by the positive sludge return system, consisting of 1 air-lift pumps. The clarifier effluent shall pass over the edge of the baffled adjustable trough and then out of the chamber.

Outlet Connection

The plant discharge connection shall be one 4" (four inch) inch FNPT collar.

Air Supply Blower Motor Units

A total of 2 positive displacement blower motor unit(s) shall be supplied, capable of providing a minimum of 2,100 cubic feet of air per pound of BOD5 delivered, and/or a minimum of 3 CFM per lineal foot of aeration tank length to meet the air requirement of the total system. Each blower shall be capable of delivering 36 CFM when operating at 4 PSI. The blower shall be manufactured by Roots, Industrial Machinery, or an approved equal. The Model number of the blower is URAI24. The motor shall be 2 HP for operating on 230 volts ac single Phase, 60 cycles and 3600 RPM. It shall be of the totally enclosed, fan cooled type. Each blower shall be mounted on an adjustable base. The base structure shall be adequately reinforced to support the blower(s) and motor(s) unit. For easy adjustment of the "V" belt drive connection between the blower and motor, the motor will be furnished with an adjustable motor mounting base. The blower shall be fitted with a dry type air filter-silencer at the air intake. The blower discharge shall be fitted with a check valve when required, and a flexible rubber discharge coupling. Each blower and motor shall be enclosed with a weatherproof enclosure. The hood is designed for easy

access to service the unit. It shall be equipped with a lifting handle and locking device. All enclosure surfaces shall be properly prepared in a neat manner to obtain a smooth, clean and dry surface. To help reduce blower vibration and noise the blower motor enclosure shall be mounted on vibration dampers. For purpose of the blower performance and/or diffuser condition, a pressure relief valve and pressure gauge shall be mounted in the air manifold.

Air Blower Motor – Compressor Package Mounting (Optional)

The air blower – compressor package will be ground mounted next to the plant to minimize noise, improve plant maintenance, and improve personnel safety.

Electrical Control Center

An electrical control panel shall be installed within a weatherproof enclosure, and shall be provided for mounting as indicated on the plans. The enclosure shall be equal to NEMA type 3-R. The electrical controls shall consist of magnetic starters, program timers, and switches necessary to automatically and manually control all electrical devices and/or motors in the sewage treatment system. The blower motor shall be controlled by selector switches and magnetic starters in conjunction with the program timer. The program timers shall have the capability to operate the treatment system when required and as determined by the variations in the daily flow rate. All electrical equipment and circuitry shall be protected by properly sized circuit breakers or fuses. All duplex or standby equipment shall be designed so that it may be operated by devices within the control system. All wire and conduit required between the control panel and the electrical power service shall be furnished and installed by the purchaser. Wiring and conduit between the control panel and plant equipment shall be furnished by the manufacturer of the waste water treatment plant. The panel may be detached for shipping. The main power supply to be furnished by the customer shall be 230 volts ac, single phase, at 60 cycles.

Electrical Control – Breaker Panels Mounting (Optional)

All Electrical circuit breaker and control panels will be mounted on the ground next to the plant where practical.

Chlorinator

A chlorine chamber, when required, shall be furnished with a baffled chamber, constructed integrally with the clarifier designed to provide disinfection of the secondary effluent. The tank shall be sized for a capacity of 110 gallons. Baffles shall be provided to eliminate short circuiting and shall be designed to keep floating material from leaving the chamber. Sufficient flow baffles will be supplied to assure proper mixing of the chlorine solution with the plant effluent. The chlorination equipment shall consist of a Norweco Tablet Feeder. The Chlorinator shall have the capacity of disinfecting the effluent from the treatment system.

Field Assembly

In almost every case, shipment on your prefabricated treatment plant is done by special lowboy trailers. When your plant is shipped by truck, delivery will be made directly to the job site. The equipment necessary to unload a plant and set it on the foundation pad must be furnished by the customer. A crane of adequate size is usually the simplest method for unloading the plant which will weigh 13,000 Lbs.

Lifting lugs are supplied on the tank to ease handling on a 4 - point sling or cable. When the plant arrives at the job site, the customer's contractor should have available the necessary equipment to unload and set the tank on the foundation pad. After setting the plant in position, a check should be made to see that it is level, and in the correct position. Our package concrete treatment system shall be completely assembled units and are shipped as a unit where shipping weight limitations permit. If a portion of the equipment must be removed to meet shipping height limitations, this equipment will be packaged separately at the factory for field assembly. This equipment and tankage should be field assembled and installed by the customer's contractor in the field.

The field contractor shall perform and/or make the following arrangements:

1. Field unloading and placing of the plant on its foundation pad, anchoring in position where required.
2. Install, at the location shown on the plan, the ancillary equipment which has been disconnected at the factory for shipping purposes.
3. Connection of piping and wiring which may have been disconnected at the factory for shipment.
4. Tie-in of all piping and wiring connections to site utilities.
5. Install drain plugs and partially fill tank with water to check for leaks, and proper rotation of 3 - phase blower and lift pumps.

Sludge Re-circulation System

There shall be installed within the clarifier chamber(s) a positive sludge return system, consisting of one 2- inch diameter airline sludge return assembly(s) meeting the following specifications: The airlift system shall have the re-circulation capacity ranging from 0% to 150% of the design flow. The airline supplying air to the system shall be equipped with a valve to vary the return capacity of the system. The airlift system shall be firmly supported and shall be equipped with a clean out plug to allow cleaning and maintenance.

Scum Re-circulation System

There shall be installed within the clarifier chamber a positive scum and skimming re-circulation system consisting of 1 airlifting skimming device(s) meeting the following specifications: The skimming device shall be of the positive airlift type, located in a position to skim and return floating material to the aeration chamber. The air line supplying air to the skimming device shall be equipped with a valve which will enable adjustment of the return flow rate. There should be an adjustable skimmer head for exact positioning of the skimmer head at water level.

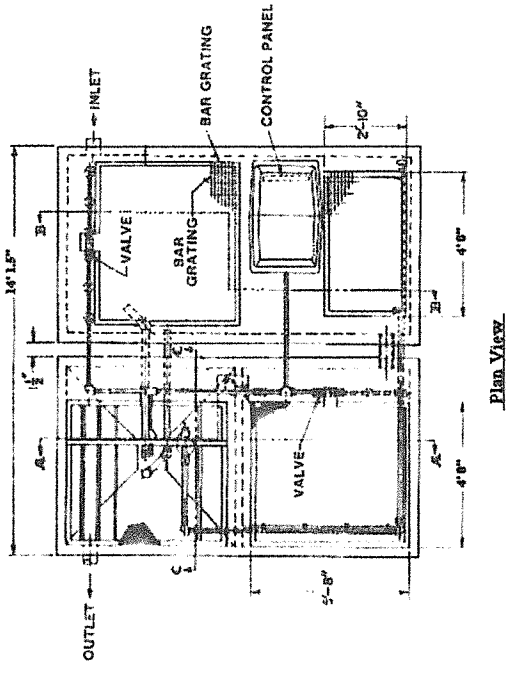

EJ BREAUX CONTRACTORS, LLC
 115 LEONIE ST.
 PIERRE PART, LA 70339
 985-252-6183

PLANT SIZE	5,000 GPD
A	103"
B	100"
C	102"
D	18"
E	101"

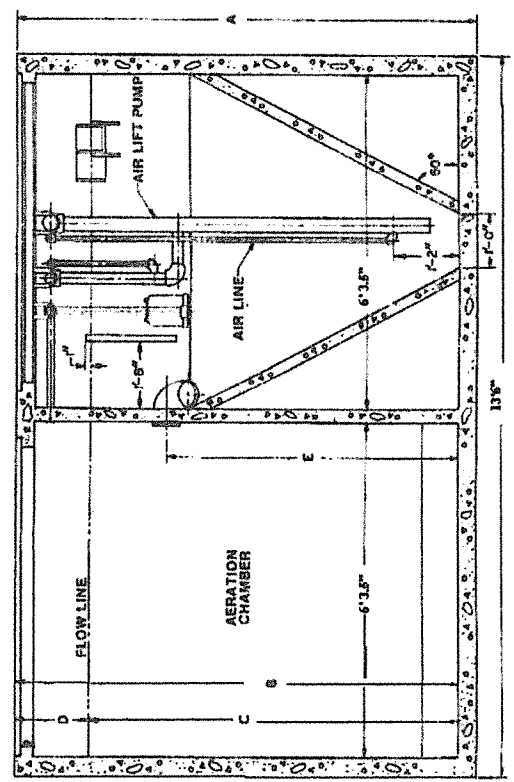
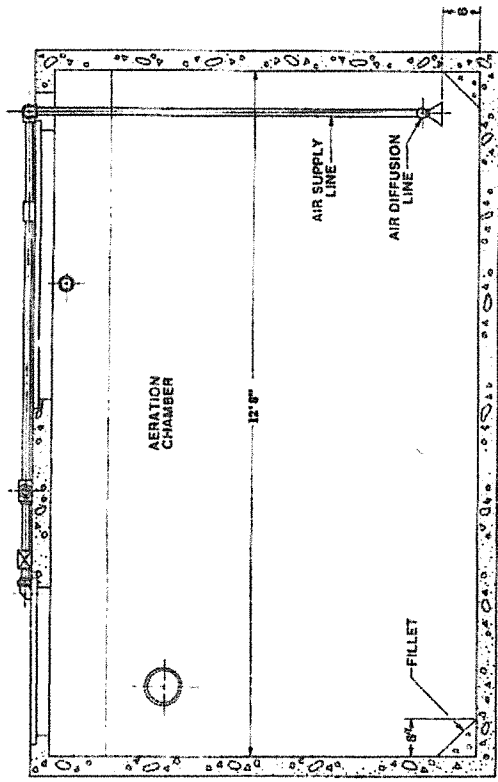
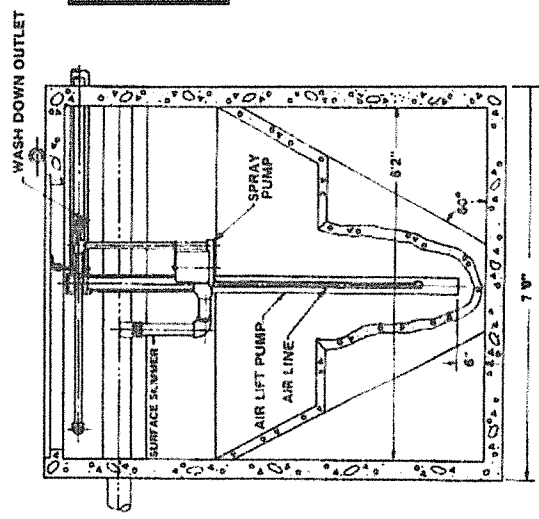

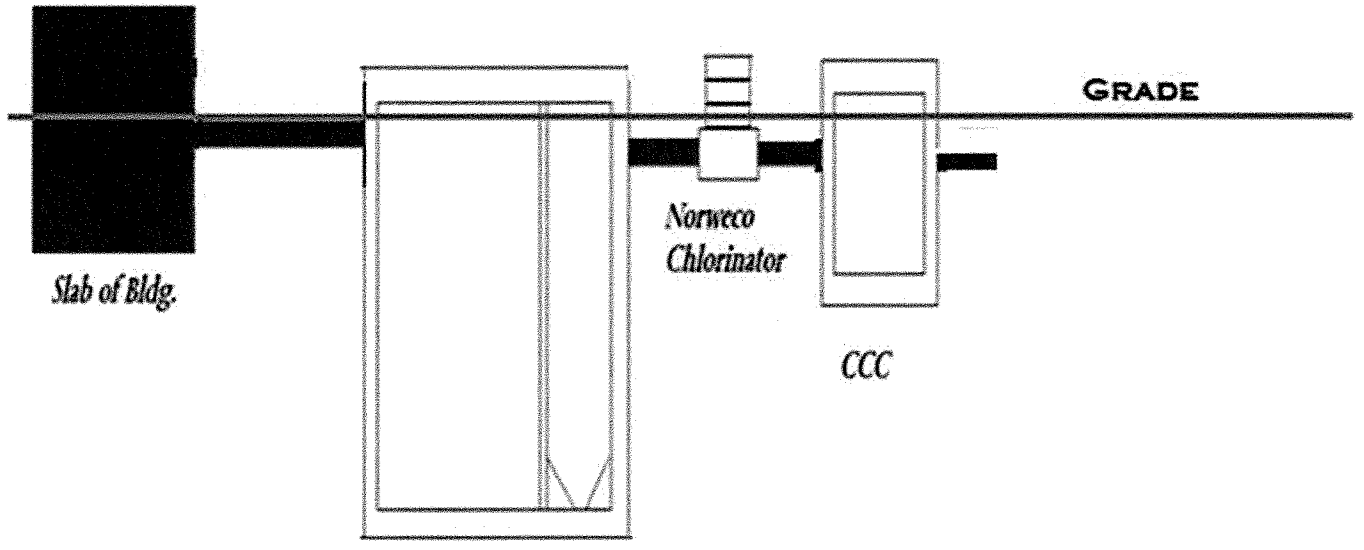

Slab of Bldg.

GRADE

*Norweco
Chlorinator*

CCC

Wastewater treatment Plant

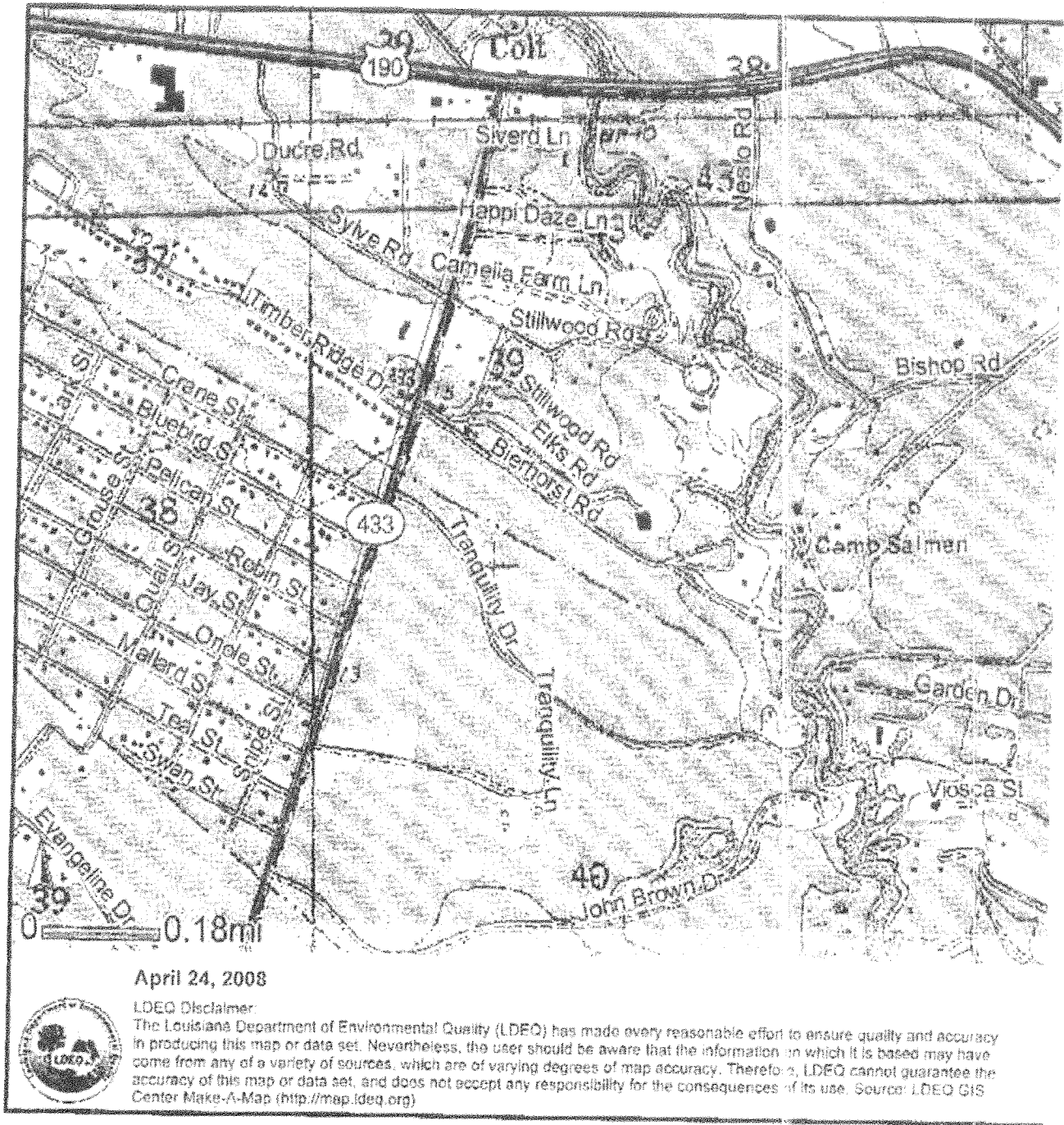

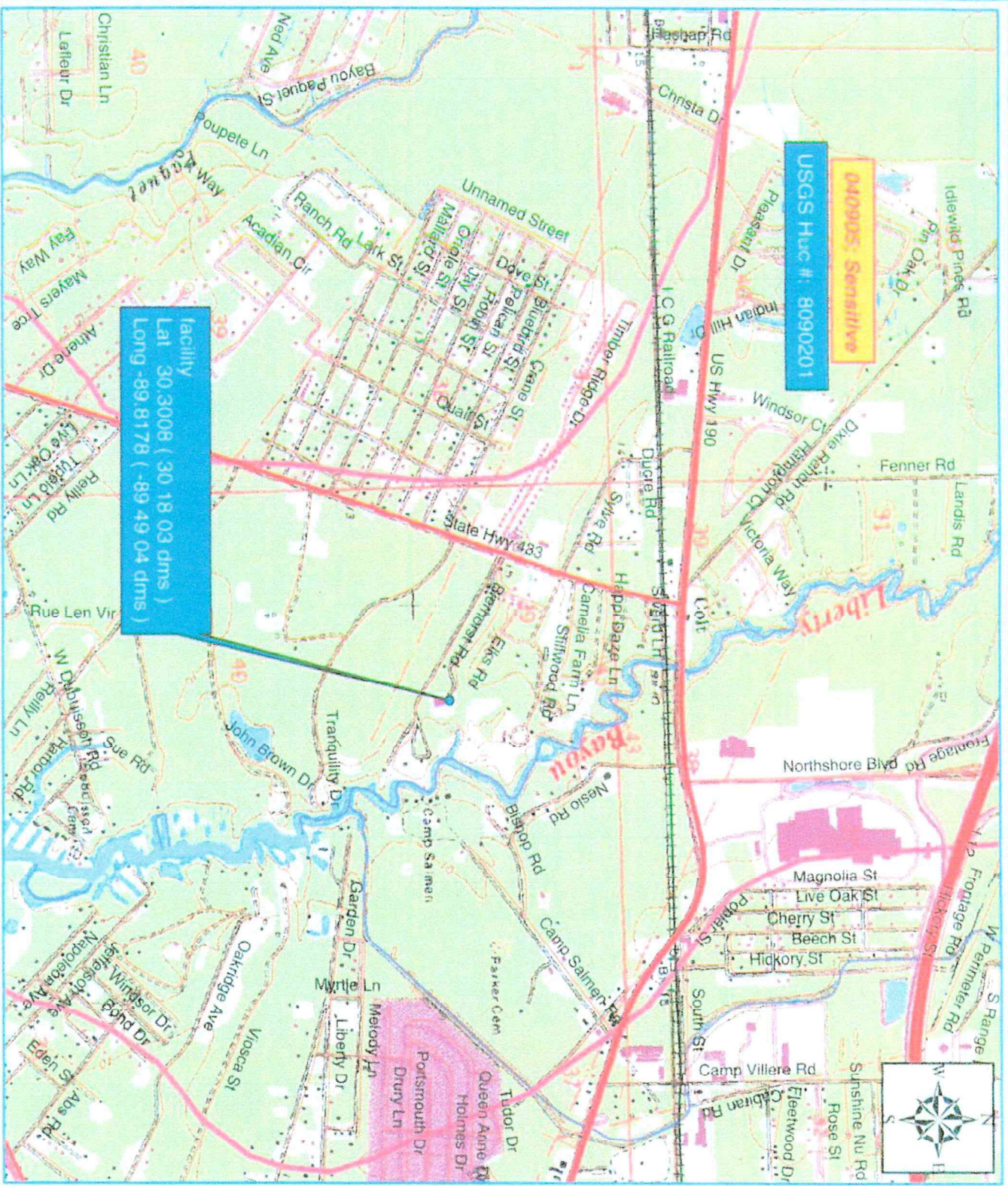

Facility
 Lat 30.3008 (30 18 03 dms)
 Long -89.8178 (-89 49 04 dms)

USGS Huc #: 8090201

0409005: Sensitive



All American Lodge
 Greatest in Elkdom
 AH# 157925

Legend

	Facility		Railroad
	church		Ferry Crossing
	hospital		River/mile mark
	school		Parish Boundaries
	Cemetery		HUC 2002
	Interstate Highway		Lease water
	US Highway		Small Water
	City/Town		Subsegments:
	State Highway		Major Water
	Major Road		Wetland
	Local Roads		Coastal Waters



LDEQ Disclaimer:
 The Louisiana Department of Environmental Quality (LDEQ) has made every reasonable effort to ensure quality and accuracy in producing this map or data set. Nevertheless, the user should be aware that the information on which it is based may have come from any of a variety of sources, which are of varying degrees of accuracy. Therefore, LDEQ cannot guarantee the accuracy of this map or data set, and does not accept any responsibility for the consequences of its use.

Creation Date: June 5, 2008. MAP# 2008-02-154. Created By: Debbie Bessard.
 Data Sources: Shape provided by All American Lodge. Grayscale in Elksdom, 2002. USGS HUC, 2004. LDEQ. Shadedrelief, 2000. Census, Tiger and Roads, 1999. ESRI. Parcels, 1999. LDEQ. Parish Boundaries, 1999. ESRI. Wetlands, 1998. USGS. Census Community, Airport/Cemetery, Wetlands from USGS, 1:500,000. DE. Co. 1:250,000. USGS. 1981. AC. 301X. Chapter 23, 1999. Lakes and Mississippi River digital from USGS, 1:250,000. ESRI. 1998. LDEQ. Water Quality Inventory. This map is intended for LDEQ internal use only.

norweco®

BIO-DYNAMIC®

FOR MODEL LF 1000, MODEL LF 2000, MODEL LF 3000

INSTALLATION AND OPERATION MANUAL

INTRODUCTION

Bio-Dynamic LF Series tablet feeders are complete dry chemical dosing systems for water, wastewater, stormwater and process water treatment. They are designed to provide automatic control over the chemical application rate and maximize installation flexibility. The LF Series tablet feeders consists of five separate models to accommodate flows ranging from less than 100 GPD through 400,000 GPD and chemical dosage ranging from 1 to 50 mg/L, depending upon the general component configuration, daily flow rate and the type of chemical tablets applied. All models of LF Series tablet feeders are manufactured from durable ABS and can be glued to Schedule 40 PVC piping. When properly installed, the Bio-Dynamic tablet feeders will provide long term, unattended operation and precise chemical application throughout their rated flow ranges. Please familiarize yourself with the contents of this manual before proceeding with installation and operation.

SYSTEM APPLICATION

Bio-Dynamic LF Series tablet feeders are designed to feed 2 5/8" diameter chemical tablets in gravity flow applications. These tablet feeders are not to be used for pressurized applications and must have a gravity outflow. Common applications for the LF Series tablet feeders are treating flows from septic tanks; aerobic treatment units; sand filters; rock reed filters; curtain drains; constructed wetlands; marine sanitation devices (MSD); individual, community and municipal drinking water systems; process water systems; reservoirs; water towers; cooling towers and irrigation systems. All LF Series tablet feeders can be installed at grade, in-line or below grade.

HOW THE LF SERIES TABLET FEEDERS WORK

Bio-Dynamic LF Series tablet feeders are flow rated proportional chemical dosing units. Flow to be treated enters the tablet feeders through the 4" integral inlet hub. The liquid then proceeds to the flow deck where the chemical tablets are contained in one to three chemical feed tubes. The number of chemical feed tubes varies by model. The flow deck has three levels (tiers) which accommodate varying hydraulic loads and properly channels liquid to the chemical tablets. Active chemicals are released into the flow stream as the liquid erodes the tablets. When the incoming flow rate increases, the liquid level in the tablet feeder rises. The increase in liquid level causes the flow to contact more tablets, thereby providing the additional chemical release required for consistent treatment. As the flow decreases, it contacts fewer tablets, reducing the chemical dosage. After contact with the chemical tablets, properly treated liquid exits the tablet feeder through the 4" outlet hub.

SYSTEM PERFORMANCE

Bio-Dynamic LF Series tablet feeders are listed as a disinfection device for secondary effluent from residential wastewater treatment systems under NSF/ANSI Standard 46. Certification requires the use of Norweco Blue Crystal or Bio-Sanitizer disinfecting tablets and a chlorine

contact tank of at least 60 gallons. Contact tank retention time must comply with the controlling regulatory jurisdiction. USEPA guidelines state "On the average, satisfactory disinfection of secondary wastewater effluent can be obtained when the chlorine residual is 0.5 ppm after 15 minutes contact." Significantly greater contact time can decrease disinfection efficiency and allow bacteria regrowth.

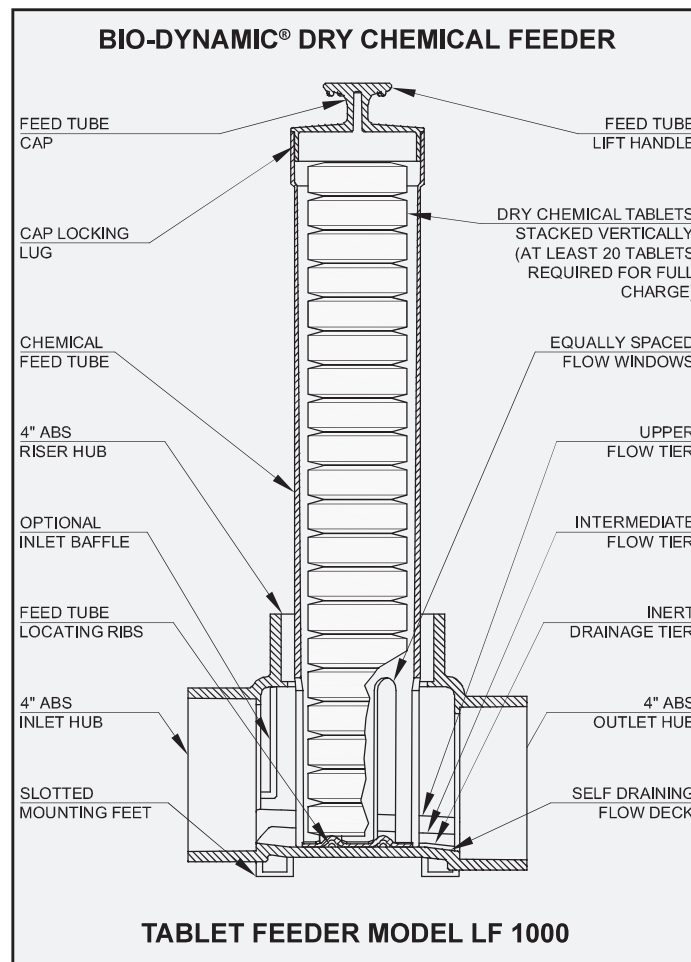

GENERAL INSTALLATION INSTRUCTIONS

Bio-Dynamic LF Series tablet feeders can be installed into any gravity flow water supply or wastewater treatment system. When used for potable water disinfection, the feeder is typically installed at grade following final filtration and just prior to a storage or detention tank. For wastewater disinfection applications, the tablet feeder is installed following clarification and prior to or in a chlorine contact tank. Installation can be at grade or direct buried. For dechlorination, feeders can be installed in or immediately following the chlorine contact tank. When chlorinating and dechlorinating effluent, two separate Bio-Dynamic tablet feeders must be installed. Do not mix chlorination and dechlorination tablets within the same tablet feeder.

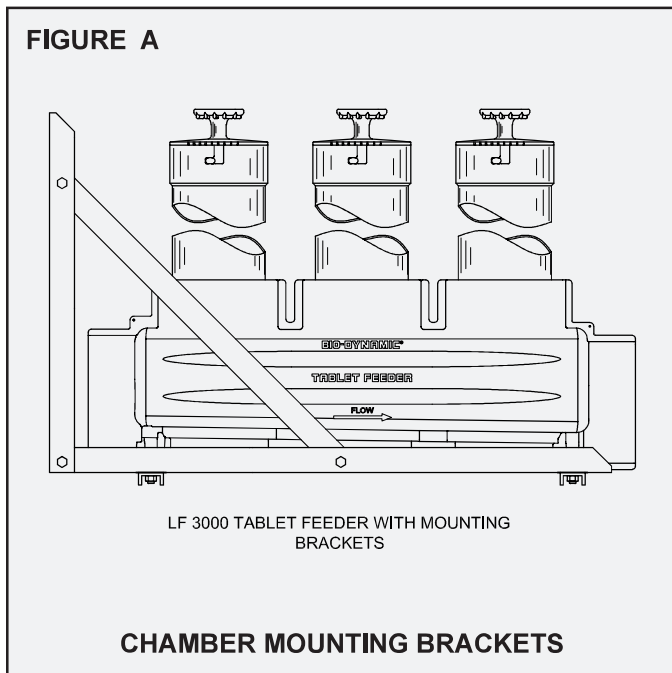

Integrally molded inlet and outlet hubs allow direct connection of the tablet feeder to Schedule 40 PVC piping. Adaptor couplings should be used, if necessary, to modify piping diameters and insure a secure piping connection to the tablet feeder. The effluent line must allow for a $\frac{1}{8}$ " fall per linear foot of run along the entire piping run. All tablet feeders must be installed plumb and level to insure proper operation. Place a bubble level on the feeder before final installation to confirm the unit is plumb and level, side to side and end to end. Always recheck level after installation.

INSTALLATION AT GRADE

LF Series tablet feeders can be installed at grade, in-line or mounted in the contact tank of a water or wastewater treatment system. The installation should be accessible for routine operator maintenance. To mount the unit, use $\frac{5}{16}$ " diameter corrosion resistant bolts to secure the four integrally molded mounting feet to the deck of the contact tank, concrete pad or mounting brackets, as required. For contact tank installations, use PVC or aluminum mounting brackets to prevent corrosion (See Figure A).

DIRECT BURIAL INSTALLATION

All models of LF Series tablet feeders may be installed below grade without a manhole or secondary enclosure. Prepare an excavation to the proper depth (See Figure B), including a sand or fine gravel leveling pad at least 4" thick. The tablet feeder must be supported by this pad before inlet and outlet piping is attached to the feeder. Excavated trenches should be smooth and free of debris to prevent damage to the pipe. Connecting lines should be laid continuously and unspliced to undisturbed earth beyond the limits of the excavation (See Figure C). Schedule 40 PVC, cast iron or similar materials may be used, subject to the approval of local codes. Attach the inlet and outlet lines to the inlet and outlet hubs using ABS compatible glue. A 4" Schedule 40 PVC pipe with tamper-proof cap (not supplied) will be used as a riser to grade. Connect the pipe to the riser hub using ABS compatible glue. Do not cement the cap. Check the system for plumb and level from side to side, end to end and vertically along the riser pipe. Backfill the excavation. Fine, loose fill should be used to backfill the excavation and plumbing line trenches. Exercise care when backfilling. Finished grade should be at least 6" below the top of the riser pipe and should slope away for surface drainage. Recheck that the feeder is plumb and level.

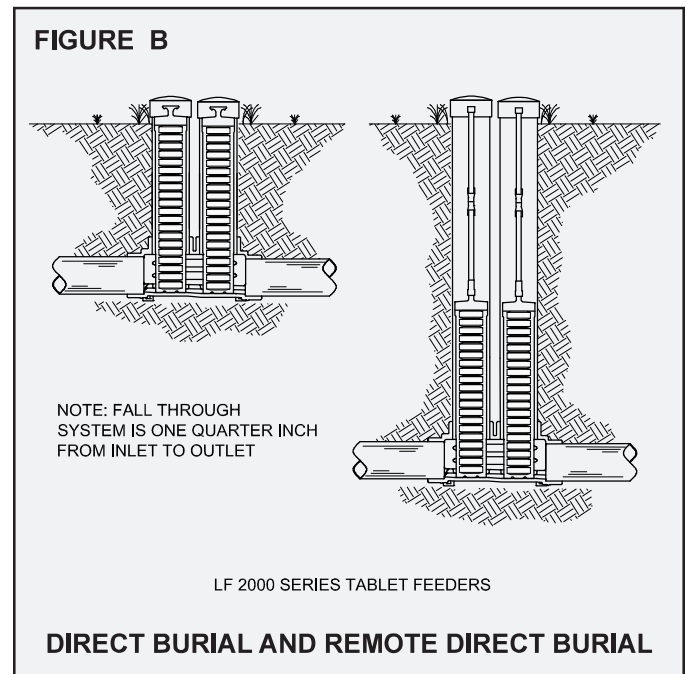

EXISTING SYSTEM RETROFIT

If the existing treatment system piping is in good condition, the feeder can be fitted directly into the appropriate location. When installing a tablet feeder into an existing disinfection system, it is recommended that the chlorine contact tank be pumped and thoroughly cleaned with a diluted bleach solution prior to installation of the feeder. Failure to properly clean the contact tank may result in inadequate disinfection of the wastewater. It is also necessary to inspect all upstream and downstream treatment components to confirm that they are installed and functioning properly.

TIERED FLOW DECK

A multi-tiered flow deck is incorporated in all LF Series tablet feeders. This allows consistent chemical application to low, sustained, variable, intermittent and surge flows. Liquid is channeled through the three tiers of the flow deck in proportion to the hydraulic load (See Figure D). The lowest tier of the flow deck is the inert drainage tier. The inert drainage tier directs liquid to the feed tube during low flow conditions and forms a drainage channel to dry the tablets when there is no flow. As the flow increases, the liquid is channeled through the intermediate flow tier. This tier directs the increased flow to the chemical tablets and allows more tablets to contact the liquid. At higher flow rates, the liquid rises to the upper flow tier. The upper tier dissipates excess flow velocity and produces a consistent chemical dosage. The flow deck incorporates a retaining ring with locating ribs for the feed tubes. The locating ribs engage positioning slots in the feed tube to secure the tube in the proper installation position for the feeder's rated capacity.

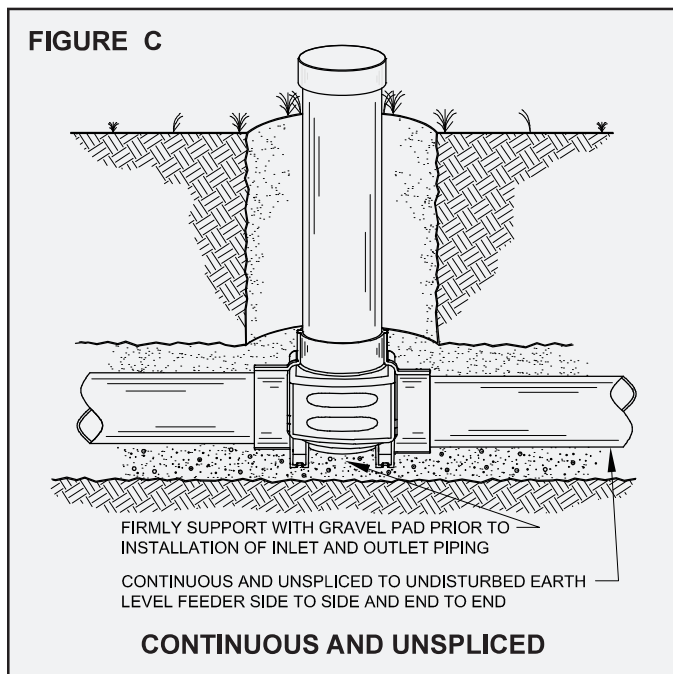

CLEARCHECK® FEED TUBE AND CAP

The LF Series tablet feeders are equipped with molded, chemical feed tubes with twist lock caps. Each feed tube and cap are constructed of NSF/ANSI Standard 61 listed PVC for durability and long life. The feed tube is manufactured with the translucent ClearCheck design. This design allows the operator or service provider to determine whether tablet refill is required simply by visual inspection without removing the tube from the feeder. The feed tube utilizes chemical tablets with the nominal weight and dimensions of 5 ounces, 2 $\frac{5}{8}$ " diameter and $\frac{13}{16}$ " to 1" height. Slots molded directly into the bottom of the feed tube allow the chemical tablets to dry during intermittent or prolonged no flow periods. The twist lock cap fits securely inside the chemical feed tube to allow convenient installation of the tube and cap within a 4" Schedule 40 PVC riser pipe.

REMOTE REMOVAL SYSTEM

A remote removal system is available for direct burial installations to allow for safe removal, recharge and reinstallation of the feed tube from grade. The remote removal system consists of a top-threaded feed tube cap, one extension and one handle. For use, replace the standard cap with the top-threaded cap. The top-threaded cap locks into the feed tube, then the extension and handle are threaded onto the top of the new cap (See Figure E). Additional extensions are available for deeper installations and can be added or removed any time. The extension(s) and handle remain in place during system operation and standard feed tube filling instructions apply.

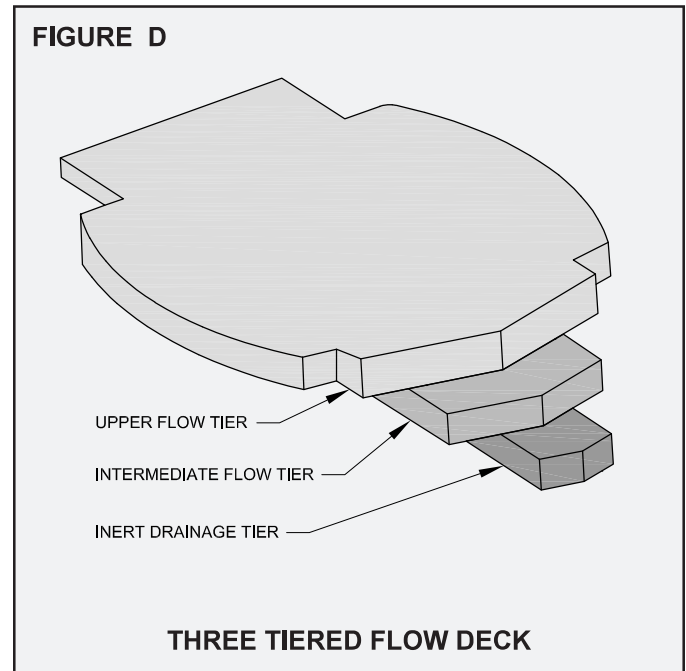

FILLING AND INSTALLING THE FEED TUBE

Before handling any chemical tablets, carefully read the product container label and the **CAUTION** section of these instructions. When filling the feed tube, always wear rubber gloves and safety goggles or a face shield for proper protection. Follow all handling instructions for the chemical tablets used. To fill the feed tube, remove it from the feeder. Rinse the feed tube and cap thoroughly with fresh water. Dry as required. Hold the tube, slotted end up, at a 30° to 45° angle and slide the chemical tablets into the open feed tube, one tablet at a time. Insure that each tablet lies flat, against the next and evenly on top of one another, in the feed tube (See Figure F). Use a gloved hand to retain the tablets inside the open end of the inverted tube until it has been evenly and completely filled. Carefully return the tube to the upright position. Replace the cap and slide the feed tube into the body of the feeder, slotted end down. The slots in the bottom of the feed tube must properly engage the locating ribs molded into the flow deck. Be sure the feed tube is fully engaged within the feeder and rests evenly on the flow deck. Utilize the Chemical Consumption Record on the back of this manual to track the chemical refill pattern.

BIO-SANITIZER® DISINFECTING TABLETS

If the tablet feeder is to be used for the disinfection of water or wastewater, a 10 lb., 25 lb., 45 lb. or 100 lb. supply of Bio-Sanitizer disinfecting tablets is available from your local distributor. Bio-Sanitizer tablets insure dependable disinfection for water and wastewater treatment system flow and other applications where a predictable long-term source of chlorine is desirable. The tablets are manufactured from pure calcium hypochlorite and contain at least 70% available chlorine. Bio-Sanitizer disinfecting tablets are registered with the USEPA for water and wastewater treatment. The tablets incorporate beveled edges to enhance the chemical dissolution pattern, providing effective and economical bacteria killing power. Each tablet is 2⁵/₈" diameter, compressed to a 1³/₁₆" thickness, has an approximate weight of 5 ounces and is white in color for easy identification. The chemical application rate of Bio-Sanitizer tablets remains consistent at peak flow factors as high as four.

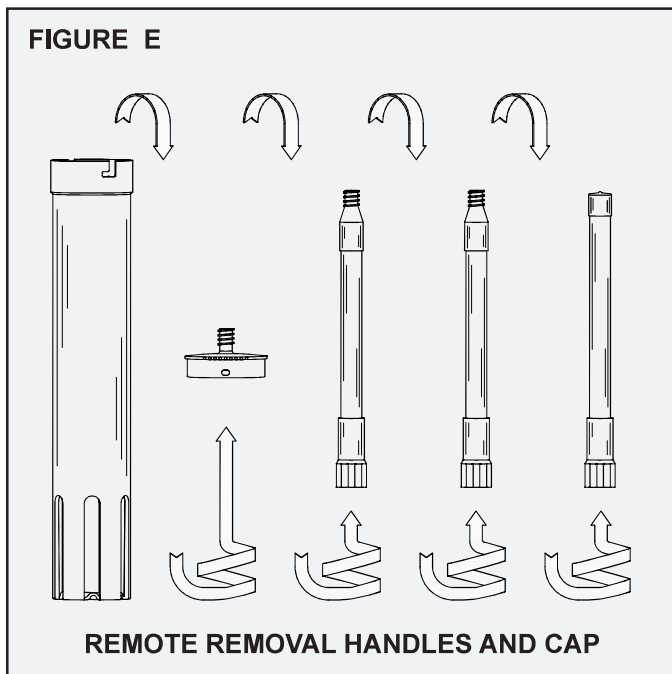

BLUE CRYSTAL® DISINFECTING TABLETS

If the tablet feeder is to be used for the disinfection of residential wastewater, a 1.9 lb., 10 lb. or 100 lb. supply of Blue Crystal residential disinfecting tablets is available from your local distributor. Blue Crystal tablets are the first disinfectant that has been specifically developed for use in residential wastewater treatment applications. Formulated to maintain positive disinfection during the low, sustained, variable and intermittent flow rates that are common to residential wastewater treatment systems, Blue Crystal tablets are produced with a proprietary beveled edge design to enhance the chemical dissolution pattern. Each tablet is 2⁵/₈" diameter, compressed to a 1" thickness, has an approximate weight of 5 ounces and is white in color with blue crystals for easy identification. Containing a minimum of 70% available chlorine, Blue Crystal tablets are registered with the USEPA for water and wastewater treatment.

BIO-MAX® DECHLORINATION TABLETS

If the tablet feeder is to be used for the dechlorination of water or wastewater a 48 lb. supply of Bio-Max dechlorination tablets is available from your local distributor. Containing 92% sodium sulfite, the tablets are manufactured to neutralize both free and combined chlorine. Bio-Max tablets incorporate beveled edges to enhance the chemical dissolution pattern. Each tablet is 2⁵/₈" diameter, compressed to a 1³/₁₆" thickness, weighs approximately 5 ounces and is green in color for easy identification. The tablets dissolve slowly, releasing controlled amounts of chemical for the instantaneous removal of residual chlorine from the water or wastewater flow. The chemical application rate of the tablets remains consistent at peak flow factors as high as four. Bio-Max tablets are formulated to remove chlorine residuals to non-detectable levels.

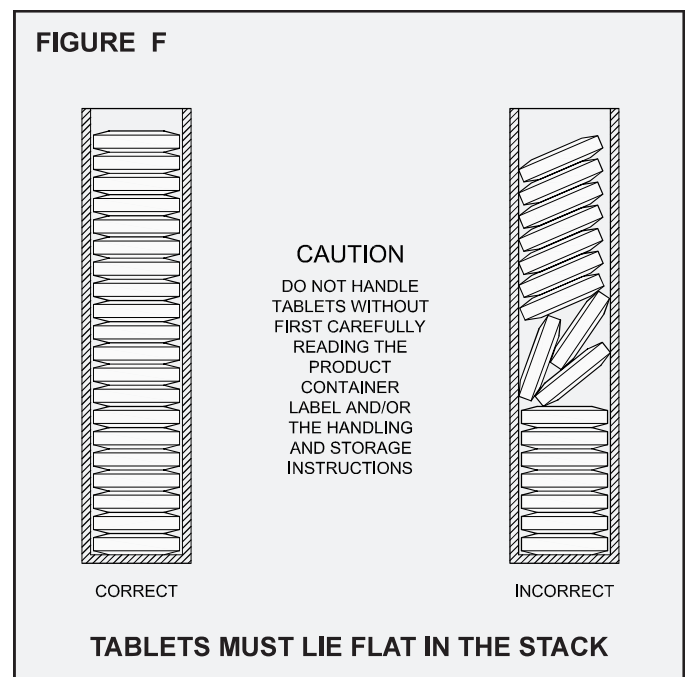

BIO-PERC® REMEDIATION TABLETS

If the tablet feeder is to be used for the bioaugmentation of wastewater, a 10 lb. supply of Bio-Perc biological remediation tablets is available from your local distributor. Bio-Perc tablets rejuvenate failing wastewater treatment systems by reducing or eliminating organic buildup in distribution lines and disposal processes. Bio-Perc tablets help sand filters and soil-based treatment systems recover their infiltrative capacity while preventing the failure of new installations. Each tablet is 2⁵/₈" diameter, compressed to a 1" thickness, has an approximate weight of 5 ounces and incorporates a beveled edge design to reduce wicking.

CAUTION: All chemicals and chemical feed systems should be handled with care. Chemicals and feed tubes should not be mixed with each other or any other products. Do not handle tablets or feed tubes without first carefully reading the product container label, SDS information and the handling and storage instructions.

PLACING THE BIO-DYNAMIC® ON-LINE

Be sure the entire liquid stream from the facility being served flows through the tablet feeder. Confirm that the proper chemical tablets are being used in the feed tube and that the feed tube is firmly engaged into the retaining ring and locating ribs of the flow deck. After the system has been in operation for at least one hour, draw a sample of the treated effluent from the feeder outlet or the contact chamber inlet to test the chemical application. For chlorination applications, testing can be done using a chlorine test kit, available from your Bio-Dynamic distributor, or a DPD Colorimetric test as outlined in the most recent edition of Standard Methods for the Examination of Water and Wastewater. Dechlorination applications may also require that a chlorine residual test be performed. Multiple samples must be taken to insure that the system has reached equilibrium. Take samples at 15 minute intervals. When three or more consecutive samples produce the same results, the system has reached equilibrium. In direct burial installations, make sure the riser pipe extends at least 6" above grade and is covered securely by a tamper-proof pipe cap.

OPERATIONAL ADJUSTMENT

LF Series feeders can be adjusted without taking the unit off-line. When fully inserted into the feeder body, the feed tube locks into locating ribs molded into the flow deck. This locked position provides the maximum chemical dose. Rotating the feed tube clockwise, one-quarter ($1/4$ "") turn from its fully locked position raises the feed tube approximately one-eighth inch ($1/8$ ""). By raising the feed tube, the chemical delivery can be reduced. Please refer to the Operational Adjustment Chart at the bottom of this page for routine guidance. If there are additional questions regarding operation, contact your local Bio-Dynamic distributor. For further reference, a red identification tag with the contact information of the manufacturer is attached to the feeder.

ROUTINE MAINTENANCE

LF Series feeders require very little maintenance other than periodic cleaning and refilling of the feed tubes. When performing maintenance, always wear rubber gloves and safety goggles or a face shield and follow the procedures outlined in the handling instructions for the chemicals used in the feeder. Before refilling the feed tubes, rinse the tube and cap thoroughly with fresh water. Occasionally, a feed tube may need to be cleaned with a brush. A service brush for cleaning the feed tube and flow deck is available from your local Bio-Dynamic distributor. To use the brush, remove the extension handle from the top-threaded feed tube cap and screw the brush into the handle. When refilling the feed tube, check the inside of the feeder and rinse any residue with a low pressure hose. Dry the feed tube with a clean cloth before reinserting chemical tablets. The liquid flow will normally prevent accumulation of debris during routine operation. Debris that may become lodged within the feeder during a malfunction of the upstream treatment system can be removed with the cleaning brush or a gloved hand.

INTERMITTENT USAGE

During a period of intermittent use or extended period of non-use, feed tubes should be removed and stored in a well-ventilated, dry, secure location. Refer to the tablet container label and safety data sheet for detailed safety, storage and/or disposal instructions for the chemical tablets. Reinstall the riser cap securely for the time period the system will be unattended.

OPERATIONAL ADJUSTMENT CHART		
Condition	Possible Cause	Recommended Remedy
Insufficient Chemical Application	Feed tube empty	Refill chemical tablets
	Incorrect type of tablets used	Replace using properly approved tablets
	Feed tube not properly installed	Install the feed tube flat on flow deck
	Tablets jammed in the feed tube	Remove, clean and properly refill the feed tube
	Excess solids in effluent	Troubleshoot treatment plant
	Debris clogging bottom of the feed tube	Remove, clean and properly refill the feed tube
	Tablet feeder not level	Adjust mounting position
	Tablets more than one year old	Remove, clean and properly refill the feed tube
Overapplication of Chemical	Incorrect type of tablets used	Replace using properly approved tablets
	Blockage at outlet	Rinse feeder with fresh water to remove blockage
	Too many tablets immersed	Rotate the feed tube clockwise 90 degrees
	Excess hydraulic flow	Equalize flow prior to the tablet feeder
	Recirculation piping not properly adjusted	Increase percentage of recirculation flow
	Tablet feeder not level	Adjust mounting position

