

DAMMON

ENGINEERING, INC.

554 Old Spanish Trail
Slidell, LA 70458
985.649.5832

www.dammonengineering.com
info@dammonengineering.com

Architects & Engineers

SHOP DRAWING and SAMPLE TRANSMITTAL

DATE: 05/19/2026

TO: Dynamic Constructors
1028 Market St.
Metairie, La. 70003
Jeffrey R. Hymel, Jr. (Jeff)

FROM: David Dammon

SUBMITTAL No.: 262416-01

REFERENCE: Fire Station #10

DE Project: 2519

WE TRANSMIT:

enclosed under separate cover _____

FOR YOUR:

use record approval
 review and comment information drafting

THE FOLLOWING:

drawing(s) contracts specifications
 shop drawings samples change order(s)
 product information warranty substitution request

# COPIES	DESCRIPTION	ACTION
Electronic	Panel Boards and Switch Gear (ATS)	C

ACTION CODES:

- A. Reviewed/No Exceptions
- B. Reviewed/Exceptions Noted
- C. Revise and Resubmit
- G. Rejected
- D. No Action Required
- E. For Signature and Return to this Office
- F. See Remarks Below

REMARKS:

1. Each panel board description does not state that it will support the proper amount and size of incoming feeders. Please revise submittal.

2. Documentation provided does not specifically state that the Thompson TS 870 is certified to work with a Generac generator. Please provide additional information.

COPIES TO: File



Transmittal Letter

PROJECT: *(Name and address)*

St. Tammany Fire Protection District No.1 - Fire Station #10
2745 Lakeshore Vista Blvd
Slidell, Louisiana 70461

TO: *(Name and address)*

Dammon Engineering Inc.
554 Old Spanish Trail
Slidell, LA 70458

FROM: *(Name and address)*

Dynamic Constructors, LLC
1028 Market St.
Metairie, LA 70003
Jeffrey R. Hymel, Jr. (Jeff)

Robin Services, Inc
529 Bellview St.
River Ridge, LA 70123
Section 262416 Panelboards - Gear

WE TRANSMIT:

Attached

Under separate cover

VIA:

Overnight delivery

Mail

E-mail

Courier

Fax

Other

FOR:

Approval / Action

Information

Use as requested

Comment

Distribution

Other

THE FOLLOWING:

Drawings

Specifications

Digital Files

Submittals

Other

NO. OF COPIES	DATE	FORMAT	DESCRIPTION
1	5.12.26	PDF	SUBMITTALS

REMARKS:

For review and approval

BY:

Dynamic Constructors, LLC, Georgia Barrett

COPIES TO:

Dammon Engineering, Inc., Chuck Dammon



Crawford Electrical Supply Company, Inc.

5500 Jefferson Hwy, New Orleans, LA. 70123

Phone: 504-731-0480

Fax: 504-731-0490

Job: St. Tammany Fire Station 10

CONTRACTOR: Robin Services

Dated: 4-24-26

Gear Submittals for Approval

SHOP DRAWING / SUBMITTAL REVIEW

REVIEWED REVIEWED AS NOTED

REVISE AND RESUBMIT REJECTED

Project No.: 2519 Submittal No.: 262416-01

Corrections or comments made on the shop drawings during this review do not relieve the contractor from compliance with requirements of the drawings and specifications. This check is only for review of the general conformance with the design concept of the project and general compliance with the information given in the contract documents. This contractor is responsible for: confirming and correlating all quantities and dimensions; selecting fabrication processes and techniques of construction; coordinating his or her work with that and other trades and performing all in a safe and satisfactory manner.

By: David Dammon Date: 05-19-26

DAMMON ENGINEERING, INC.

Slidell, LA

Proposal Name: St. Tammany Fire Station 10

Quote Name: St. Tammany Fire Station 10

Proposal #: P-260225-5876743

Quote #: Q-6754360

Addendum #: 0

Quote Date: 02/26/2026

Sales Representative:

Prepared For:

Distributor: CRAWFORD ELECTRIC SUPPLY CO INC

Prepared By:

Karson Meariman

5500 Jefferson Hwy

New Orleans, 70123

kmeariman@crawfordelectricsupply.com

D:504-258-1273

Prepared By:

Karson Meariman
5500 Jefferson Hwy
New Orleans, 70123
kmeariman@crawfordelectricsupply.com
D:504-258-1273

Proposal Name: St. Tammany Fire Station 10

Quote Name: St. Tammany Fire Station 10

Proposal Number: P-260225-5876743

Quote Number: Q-6754360

Quote Date: 02/26/2026

Through Addenda Number: 0

Sales Representative:

Conditions of Sale

Except as otherwise provided below, this Quotation is subject to Coordinated Project Terms. See <https://www.schneider-electric.us/en/download/document/0100PL0043>

Notwithstanding any provision to the contrary in the referenced Coordinated Project Terms or any other documentation provided in connection with this proposal, this quote is valid for 30 days. Quoted lead times are approximate and subject to change.

Schneider Electric reserves the right to amend, withdraw or otherwise alter this submission without penalty or charge as a result of any event beyond its control arising from or due to the current Covid-19 epidemic or events subsequent to this epidemic / pandemic including changes in laws, regulations, by laws or direction from a competent authority.

SUMMARIZED BILL OF MATERIAL

Qty	Product Description Seq #: Designation
3	Panelboards 1: Panel MDP, 2: Panel PP, 3: Panel LP
15	Safety Switches 4: 400A FDS, 5: 60A FDS, 6: 60A FDS, 7: 30A FDS, 8: 30A FDS

TABLE OF CONTENTS

Panelboards

Safety Switches

This Section Contains Products: Panelboards

Seq #	Qty	Product Description
1	1	Designation : Panel MDP

Product Details:

1-NQ ML Panel (INTERIOR)-NQ Panelboard
 Consisting of
 120/240V 1Ph 3W 60Hz SCCR: 22kA
 Fully Rated
 Main Lug Only: 400A
 Branch Neutral Lug Material: Copper
 Main Acc: Cu Mechanical Lugs Cu Cable
 Incoming Conductors: 1 - 1/0 - 750, (2) 1/0 - 350 kcmil
 Bus: 400A Rated Copper: Silver/Tin Plated
 CU Ground Bar
 42 Circuit Interior
 Type 1,Box: 74H x 20W x 5.75D
 Incoming: Top Trim: Surface with Door
 Box Cat No: MH74BE Front Cat No: NC74VS
 Ref. Drawing: PBA709A
 Feeders:
 4 - 50A/2P QOB-VH
 1 - 40A/2P QOB-VH
 6 - 15A/2P QOB-VH
 10 - 20A/1P QOB-VH
 1 - 15A/1P QOB-VH
 7 - 20A/1P QOB-VH Prepared Space
 1 - 30A/2P QOB-VH
 2 - Sub-Feed Circuit Breakers: 200A/2P QD
 Optional Features:
 Standard Panel (Box Ahead),Blank
 Endwalls,Copper Solid Neutral,Copper
 Ground Bar
 Branch User Placement
 Standard Nameplate:
 Engraved as Follows
 Line 1: Panel MDP
 Size: 3.50" Wide x 1.00" High (Std)
 Color: White Surface / Black Letters
 Plastic/Adhesive - Screw-on
 1-MH74BE-PANELBOARD ENCLOSURE/BOX TYPE 1 74H 20W
 1-NC74VS-PANELBOARD COVER/TRIM NF TYPE 1 VS 74H
 Estimated days to ship, excluding transit: 35 working days after customer release to manufacturer. See Conditions of Sale.

Does this mean only one single feeder can be 500 mcm; but two 350 mcm?

Seq #	Qty	Product Description
2	1	Designation : Panel PP

Product Details:

1-NQ ML Panel (INTERIOR)-NQ Panelboard
 Consisting of
 120/240V 1Ph 3W 60Hz SCCR: 22kA
 Fully Rated
 Main Lug Only: 200A
 Branch Neutral Lug Material: Copper
 Main Acc: Cu Mechanical Lugs Cu Cable
 Incoming Conductors: 1 - #6 - 250 kcmil
 Bus: 225A Rated Copper: Silver/Tin Plated
 CU Ground Bar
 42 Circuit Interior
 Type 1,Box: 38H x 20W x 5.75D
 Incoming: Top Trim: Surface with Door
 Box Cat No: MH38BE Front Cat No: NC38S
 Ref. Drawing: PBA701A
 Feeders:
 3 - 20A/1P QOB-VH-GFI
 3 - 20A/2P QOB-VH
 33 - 20A/1P QOB-VH
 Optional Features:
 Standard Panel (Box Ahead),Blank
 Endwalls,Copper Solid Neutral,Copper



Ground Bar
 Branch User Placement
 Standard Nameplate:
 Engraved as Follows
 Line 1: Panel PP
 Size: 3.50" Wide x 1.00" High (Std)
 Color: White Surface / Black Letters
 Plastic/Adhesive - Screw-on
 1-MH38BE-PANELBOARD ENCLOSURE/BOX TYPE 1 38H 20W
 1-NC38S-PANELBOARD COVER/TRIM NF TYPE 1 S 38H
 Estimated days to ship, excluding transit: 35 working days after customer release to manufacturer. See Conditions of Sale.

Seq #	Qty	Product Description
3	1	Designation : Panel LP

Product Details:
 1-NQ ML Panel (INTERIOR)-NQ Panelboard
 Consisting of
 120/240V 1Ph 3W 60Hz SCCR: 22kA
 Fully Rated
 Main Lug Only: 200A
 Branch Neutral Lug Material: Copper
 Main Acc: Cu Mechanical Lugs Cu Cable
 Incoming Conductors: 1 - #6 - 250 kcmil
 Bus: 225A Rated Copper: Silver/Tin Plated
 CU Ground Bar
 30 Circuit Interior
 Type 1,Box: 32H x 20W x 5.75D
 Incoming: Top Trim: Surface with Door
 Box Cat No: MH32BE Front Cat No: NC32S
 Ref. Drawing: PBA701A
 Feeders:
 1 - 15A/2P QOB-VH
 22 - 20A/1P QOB-VH
 Optional Features:
 Standard Panel (Box Ahead),Blank
 Endwalls,Copper Solid Neutral,Copper
 Ground Bar
 Standard Nameplate:
 Engraved as Follows
 Line 1: Panel LP
 Size: 3.50" Wide x 1.00" High (Std)
 Color: White Surface / Black Letters
 Plastic/Adhesive - Screw-on
 1-MH32BE-PANELBOARD ENCLOSURE/BOX TYPE 1 32H 20W
 1-NC32S-PANELBOARD COVER/TRIM NF TYPE 1 S 32H
 Estimated days to ship, excluding transit: 35 working days after customer release to manufacturer. See Conditions of Sale.

This Section Contains Products: Safety Switches



Proposal Name: St. Tammany Fire Station
10
Quote Name: St. Tammany Fire Station 10

Quote Number: Q-6754360
Quote Date: 02/26/2026

Seq #	Qty	Product Description
4	1	Designation : 400A FDS

Product Details:
1-H225NR-SW,FUSIBLE 240V 400A 2P NEMA3R/NEUTRAL
Enclosure Type: Type 3R
Interrupting Rating (AIR): 200kA
Fuse Capability: Class R
Max System Voltage: 240 Vac / 250 Vdc
Switch Current Rating: 400A
System Used: 3 Wire (2 Poles, 1 Neutral)
Neutral Kit: Include
Ground Lug: PKOGTA2
Processed by ACE 2.0 - 04172018
1-PKOGTA2-EQUIP GRD ASSY 240V + 600V 100-200

Seq #	Qty	Product Description
5	1	Designation : 60A FDS

Product Details:
1-VH222N-HDSS TYPE1 240V 60 AMP 2 POLE Fuse
Enclosure Type: Type 1
Interrupting Rating (AIR): 200kA
Fuse Capability: Class R
Max System Voltage: 240 Vac / 250 Vdc
Switch Current Rating: 60A
System Used: 3 Wire (2 Poles, 1 Neutral)
Neutral Kit: Include
Covering View Window: Factory Add
Ground Lug: GTK03
Processed by ACE 2.0 - 04172018
1-GTK03-KIT EQUIPMENT GROUND CU/AL

Seq #	Qty	Product Description
6	3	Designation : 60A FDS

Product Details:
3-VH222NRB-HDSS TYPE3R 240V 60 AMP 2 POLE Fuse
Enclosure Type: Type 3R
Interrupting Rating (AIR): 200kA
Fuse Capability: Class R
Max System Voltage: 240 Vac / 250 Vdc
Switch Current Rating: 60A
System Used: 3 Wire (2 Poles, 1 Neutral)
Neutral Kit: Include
Covering View Window: Factory Add
Ground Lug: GTK03
Processed by ACE 2.0 - 04172018
3-GTK03-KIT EQUIPMENT GROUND CU/AL

Seq #	Qty	Product Description
7	9	Designation : 30A FDS

Product Details:
9-VH221N-HDSS TYPE1 240V 30 AMP 2 POLE Fuse
Enclosure Type: Type 1
Interrupting Rating (AIR): 200kA
Fuse Capability: Class R
Max System Voltage: 240 Vac / 250 Vdc
Switch Current Rating: 30A
System Used: 3 Wire (2 Poles, 1 Neutral)
Neutral Kit: Include
Covering View Window: Factory Add
Ground Lug: GTK03
Processed by ACE 2.0 - 04172018
9-GTK03-KIT EQUIPMENT GROUND CU/AL



Proposal Name: St. Tammany Fire Station
10
Quote Name: St. Tammany Fire Station 10

Quote Number: Q-6754360
Quote Date: 02/26/2026

Seq #	Qty	Product Description
8	1	Designation : 30A FDS

Product Details:

1-VH221NRB-HDSS TYPE3R 240V 30 AMP 2 POLE Fuse
Enclosure Type: Type 3R
Interrupting Rating (AIR): 200kA
Fuse Capability: Class R
Max System Voltage: 240 Vac / 250 Vdc
Switch Current Rating: 30A
System Used: 3 Wire (2 Poles, 1 Neutral)
Neutral Kit: Include
Covering View Window: Factory Add
Ground Lug: GTK03
Processed by ACE 2.0 - 04172018
1-GTK03-KIT EQUIPMENT GROUND CU/AL



SERIES TS 870 • 100 - 1200 AMP AUTOMATIC TRANSFER SWITCH

COMMERCIAL, INDUSTRIAL



TS 870 AUTOMATIC TRANSFER SWITCHES OFFER:

ENCLOSED CONTACT POWER SWITCHING UNITS

- Fully enclosed silver alloy contacts provide high withstand rating & 100% continuous current rating
- 3 cycle short circuit current withstand
- 10 cycle 6X overload current rating
- Completely isolated utility and generator side power switching units
- Power switching units can incorporate over current protection, allowing cost savings in upstream devices
- Switching manually will prevent damage while in service

RELIABLE MOTOR-OPERATED TRANSFER MECHANISM

- Heavy duty brushless gearmotor and operating mechanism provide mechanical interlocking (for open transition ATS) and longer product life
- Stored Energy: Motor Operators for fast CTTS
- Safe manual operation permits operation under adverse conditions

SUPERIOR SERVICEABILITY

- All mechanical and control devices are visible and front accessible
- All control wires and power busses are front accessible
- Plug-in TSC 7320 Transfer Switch Controller

CONTROL FEATURES

- TSC 7320 Advanced ATS Controller with 2.3" back-lit LCD display and programmable inputs/outputs
- Isolation plug permits disconnecting control circuits from all power sources

PRODUCT DATA

- Models from 100 - 1200A continuous current
- Available 2, 3 or 4 pole
- All models 50/60Hz rated
- Voltage range 120 - 600VAC
- 3 phase, 3 or 4 wire systems
- Open Transition or Closed Transition ATS
- 1000 - 1200A offer fast Open Transition transfer, with phase monitoring

SEISMIC CERTIFICATION:

TS 870 ATS is certified for installation and operation per the following requirements:

- IBC 2012 – Section 13, Occupancy Category IV
- ASCE7 - 05 Region 3 (minimum SS=200%)

SAFETY STANDARDS

- UL™* 1008 Automatic Transfer Switches for use in Emergency Systems
- CSA™* C22.2 No. 178 Automatic Transfer Switches
- NFPA™* 110 Standard for Emergency and Standby Power Systems

WARRANTY

- 2 year limited warranty included

TS 870 Automatic Transfer Switches employ two mechanically interlocked power switching units with an Advanced ATS Controller to automatically start a generator and transfer system load to a generator supply in the event of a utility supply failure. System load is then automatically re-transferred back to the utility supply following restoration of the utility power source to within normal operating limits. All load transfer sequences are "Open Transition" (i.e., break-before-make) with adjustable neutral position delay to ensure adequate voltage delay for preventing out of phase transfers .

TS 870 Automatic Transfer Switches are certified to UL 1008 & CSA 178 Standards for use in Emergency Power Systems applications.

All TS 870 Transfer Switch models have been 3 cycle withstand current tested in accordance with UL 1008 & CSA 178. Additionally, they can withstand 6 times overload for 10 cycles. The standard TS 870 Automatic Transfer Switch is rated for 100% system load. The TS 870 design allows for optional use of integral over current trip elements within the power switching units. All TS 870 Automatic Transfer Switches use a TSC 7320 Advanced ATS Controller which provides all necessary control functions for fully automatic operation. The controller is equipped with 2.3" back-lit LCD display which provides operating status and controls. All parameters and configurations are entered without opening the front door.

* See last page for attribution.

CLOSED TRANSITIONS ATS (MOMENTARY)

TS 870 Closed Transition Transfer Switch (1000A - 1200A CTTS) employs two stored energy, motor operated electrically interlocked molded case (MCCB/MCS) power switching units and an Advanced ATS Controller to automatically allow a Closed Transition ("make-before-break") load transfer when both utility and generator sources are available. All Closed Transition transfer sequences ensure both sources of power are in synchronism prior to transfer and load is transferred without power interruption. Automatic control & protection circuits ensure the generator and utility supplies are only in parallel for a maximum of 100 ms to permit an uninterrupted load transfer.

In the event of a utility supply failure, the TS 870 CTTS will automatically revert to an Open Transition load transfer sequence to transfer system load automatically to the generator supply. System load is then automatically re-transferred back to the utility supply utilizing a Closed Transition transfer sequence following restoration of the utility power source to within normal operating limits. All Closed Transition transfer sequences will be inhibited when only one source of power is available. The Closed Transition feature is a standard option that can be applied to the TS 870 model.

TS 870 CTTS are specifically designed and certified to UL™* 1008 Standards, for use in Emergency Power Systems applications such as commercial, industrial, or government institutions that require automatic standby power and minimal power interruptions to the load.

The TS 870 CTTS use the TSC 7320 controller, with built-in Sync Check relay, which contains adjustable voltage differential/slip frequency threshold limits. The paralleling time is less than 100ms. A timer monitors the Closed Transition period, and will isolate, should the closed-transition time exceed the setting of the timer. If the device fails to open within 100ms, an additional Extended Paralleling Protection is provided to ensure isolation by opening the other source within 500ms.

Closed Transition Mode can be bypassed to Open Transition Mode within the TSC 7320 Controller. An Auto/Manual Switch is provided for safe manual operation in Open Transition mode with positive pushbutton controls.

Note: 400 - 800A CTTS are implemented using the TSC 900 controller



CONTROLLER SYNC SCREEN EXAMPLES

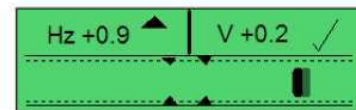

Figure 1

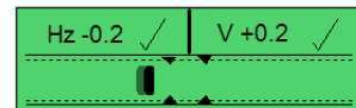

Figure 2

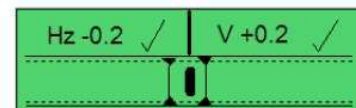

Figure 3

* See last page for attribution.

BYPASS ISOLATION ATS

Note: TS870 400A to 800A 4 Breaker bypass configuration ATS is implemented using the TS870 with TSC900 controller. Refer to the TS870 Commercial & Industrial ATS datasheet CL062 for details.

TS 870 Bypass/Isolation Automatic Transfer Switches employ an interlock power switching mechanism that provides an easy and safe procedure for system maintenance personnel to manually isolate and bypass an Automatic Transfer Switch. The Bypass/Isolation switch is manually operated, and allows either generator or utility source to be bypassed to maintain power to the load while the Automatic Transfer Switch is tested for maintenance procedures as required. The Bypass/Isolation procedure allows a fast, simple, and reliable method of isolating and bypassing the Automatic Transfer Switch through a "make-before-break" bypass design. The interlocking mechanism ensures that the utility and generator sources cannot be paralleled under any circumstance and the transfer switch may be bypassed to either source.

The TS 870 Bypass/Isolation Automatic Transfer Switch is supplied as a single complete assembly with all power conductors provided between the bypass mechanism and the transfer switch. Provisions for all external power cabling for the utility, generator and load conductors are provided for in the bypass/isolation compartment of the switch. The Bypass/Isolation Switch and Transfer Switch are mounted in separate barriered compartments.

For transfer switches rated 1000A - 1200A using molded case power switching devices, the bypass/isolation mechanism consists of two electrically interlocked power switch devices and draw-out transfer power switching devices. Utilizing independent switching units provides a high degree of reliability and redundancy not available in other switches.

TS 870 Bypass/Isolation Automatic Transfer Switches are specifically designed and certified to UL™* 1008 and CSA™*22.2 No. 178 Safety Standards

All TS 870 Bypass/Isolation Automatic Transfer Switch models have been 3 cycle withstand current tested in accordance with UL 1008 and CSA 22.2 No.178.

The standard TS 870 Bypass/Isolation Automatic Transfer Switch is rated 100% system load and requires upstream over current protection

Note: Automatic Transfer Switch units rated 1000A - 1200A utilizing insulated case power switching units with a closed transition option may be operated in a "make-before-break" sequence at the operators' direction.



1000A/ 1200A TS870 Bypass,
4 breaker configuration

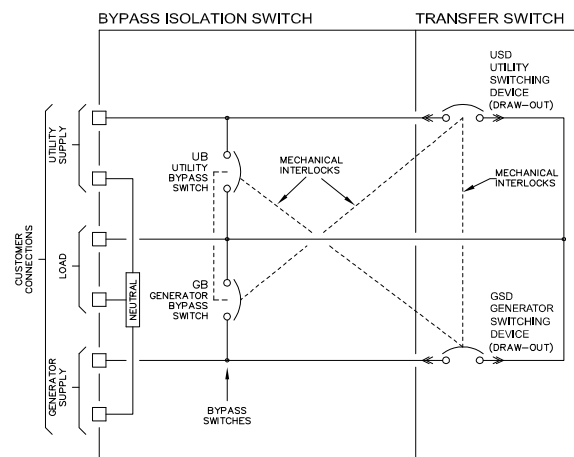

1000A - 1200A Molded Case
Bypass/Isolation Automatic Transfer Switch

TYPICAL SINGLE LINE DIAGRAM

* See last page for attribution.

SERVICE ENTRANCE ATS (For U.S. Market Only)

TS 870 Service Entrance (SE) Automatic Transfer Switches incorporate an isolating mechanism and over current protection on the utility supply, thereby removing the need to have a separate, upstream circuit breaker/ disconnect switch. This unique Service Entrance Rated Automatic Transfer Switch design is incorporated into a standard sized Automatic Transfer Switch enclosure.

Standard features of the Service Entrance Rated Automatic Transfer Switch include a NEMA®* 1 rated enclosure, pad-lockable Service Disconnect control switch and status indications.

TS 870 SE Service Disconnect operation ensures a high level of safety for system maintenance personnel. Normal operation and performance of the Automatic Transfer Switch is unaffected by the Service Entrance ATS feature. The TS 870 SE Automatic Transfer Switch is rated for the system load and requires upstream over current protection on the generator supply.

TS 870 SE Automatic Transfer Switches use a type TSC 7320 microprocessor based controller.

TYPICAL SINGLE LINE DIAGRAM

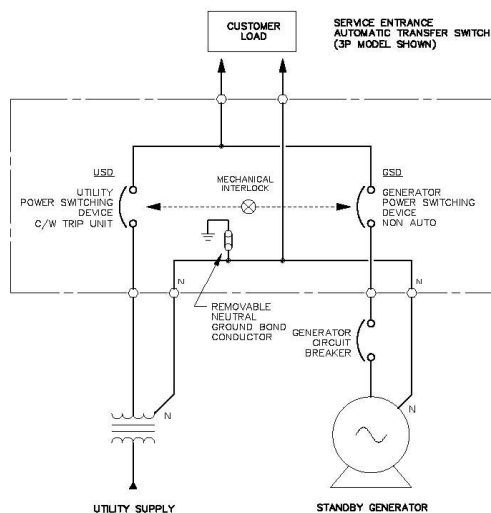

* See last page for attribution.

WITHSTAND CURRENT RATINGS (3 CYCLE MODELS)

MODEL	Type	MAX VOLTAGE	WITHSTAND CURRENT RATING AMPS (RMS) ¹		
			@240V	@480V	@600V
TS 87xA-0100	100A	600	65,000	25,000	18,000
TS 87xA-0150	150A	600	65,000	25,000	18,000
TS 87xA-0200	200A	240	65,000	N/A	N/A
TS 87xA-0250	250A ²	600	65,000	65,000	35,000
TS 87xA-0400	400A	600	65,000	50,000	35,000
TS 87xA-0600	600A	600	65,000	50,000	35,000
TS 87xA-0800	800A	600	65,000	50,000	35,000
TS 87xA-1000	1000A	600	150,000	100,000	65,000
TS 87xA-1200	1200A	600	150,000	100,000	65,000

¹ Note: For power switching devices equipped with optional over current trip units, standard interrupting ratings are identical to withstand ratings shown at 240V and 480V. For interrupting ratings at 600V, contact Thomson Technology Power Systems.

² Note: Withstand rating specified is for 250A, 3P. For 250A, 4P, the withstand ratings are 65KA@240V, 35KA@480V and 22KA@600V.

ENCLOSURE DIMENSIONS/CABLE TERMINALS (ATS ONLY) (NEMA®* 1, ASA #61 GRAY)

AMPERAGE	# OF POLES	DIMENSIONS ¹			SHIPPING WEIGHT lbs (kg)	TERMINAL RATING ²	
		HEIGHT INCHES (mm)	WIDTH INCHES (mm)	DEPTH ³ INCHES (mm)		QTY (PER PHASE)	RANGE
100A	2, 3, 4	31.1 (790)	22.3" (566)	14" (356)	143 lbs (65)	1	#14 - 1/0
150A	2, 3, 4	31.1" (790)	22.3" (566)	14" (356)	143 lbs (65)	1	#2 - 4/0
200A	2, 3, 4	31.1" (790)	22.3" (566)	14" (356)	143 lbs (65)	1	#6 - 350 mcm
250A	2, 3, 4	35.1" (892)	27.3" (693)	14" (356)	172 lbs (78)	1	#6 - 350 mcm
400A	2, 3	43.1" (1095)	34.3" (873)	13" (330)	227 lbs (103)	2	2/0 - 500 mcm
400A	4	48.1" (1222)	37.8" (960)	14.5" (368)	256 lbs (116)	2	2/0 - 500 mcm
600A	2, 3	46.1" (1171)	36.3" (922)	14.5" (368)	248 lbs (113)	2	2/0 - 500 mcm
600A	4	48.1" (1222)	37.8" (960)	14.5" (368)	256 lbs (116)	2	2/0 - 500 mcm
800A	2, 3	48.1" (1222)	37.8" (960)	14.5" (368)	309 lbs (140)	3	2/0 - 500 mcm
800A	4	63.1" (1603)	40.8" (1036)	14.5" (368)	367 lbs (167)	3	2/0 - 500 mcm
400A - 800A CTTS	2, 3, 4	64" (1626)	30" (762)	13" (330)	400 lbs (181)	3	2/0 - 500 mcm
1000A/1200A (ALL)	2, 3, 4	70" (1780)	34.3" (871)	14" (356)	550 lbs (249)	4	4/0 - 500 mcm

¹ Enclosure dimensions are for reference. (NOT FOR CONSTRUCTION).

³ All cable connections suitable for copper or aluminum.

⁴ Optional terminal ratings are available in some models - Consult Thomson Technology Power Systems.

* See last page for attribution.

Optional NEMA 3R & 4X class enclosures available - Consult Thomson Technology Power Systems.

For ATS with Distribution Breaker Option - Contact factory for dimensions.

ENCLOSURE DIMENSIONS/CABLE TERMINATIONS (ATS WITH BYPASS SWITCH)

NEMA® 1 Standard

AMPER-AGE	# OF POLES	DIMENSIONS ¹			SHIPPING WEIGHT lbs (kg)	TERMINAL RATING ²	
		HEIGHT INCHES (mm)	WIDTH INCHES (mm)	DEPTH ³ INCHES (mm)		QTY (PER PHASE)	RANGE
400A	3	80" (2032) (790)	36" (914) (566)	24" (610) (356)	955 lbs	2	#2 - 500 mcm
400A	4	80" (2032) (790)	48" (1219) (566)	22" (559) (356)	1260 lbs	2	#2 - 500 mcm
600A	3	80" (2032) (790)	36" (914) (566)	24" (610) (356)	1075 lbs	2	#2 - 500 mcm
600A	4	80" (2032) (892)	48" (1219) (693)	22" (559) (356)	1340 lbs	2	#2 - 500 mcm
800A	3	80" (2032) (1095)	36" (914) (873)	24" (610) (330)	1075 lbs	3	#2 - 500 mcm
800A	4	80" (2032) (1222)	48" (1219)(960)	22" (559) (368)	1340 lbs	3	#2 - 500 mcm
1000A	3	80" (2032) (1171)	48" (1219)(922)	22" (559) (368)	1415 lbs	4	#4 - 500 mcm
1000A	4	80" (2032) (1222)	48" (1219)(960)	22" (559) (368)	1474 lbs	4	#4 - 500 mcm
1200A	3	80" (2032) (1222)	48" (1219)(960)	22" (559) (368)	1415 lbs	4	#4 - 500 mcm
1200A	4	80" (2032) (1603)	48" (1219)(1036)	22" (559)n(368)	1474 lbs	4	#4 - 500 mcm

NEMA 3R Option

AMPER-AGE	# OF POLES	DIMENSIONS ¹			SHIPPING WEIGHT lbs (kg)	TERMINAL RATING ²	
		HEIGHT INCHES (mm)	WIDTH INCHES (mm)	DEPTH ³ INCHES (mm)		QTY (PER PHASE)	RANGE
400A	3	80" (2032) (790)	48" (1219) (566)	22" (559) (356)	1550 lbs	2	#2 - 500 mcm
400A	4	80" (2032) (790)	48" (1219) (566)	22" (559) (356)	1535 lbs	2	#2 - 500 mcm
600A	3	80" (2032) (790)	48" (1219) (566)	22" (559) (356)	1540 lbs	2	#2 - 500 mcm
600A	4	80" (2032) (892)	48" (1219) (693)	22" (559) (356)	1584 lbs	2	#2 - 500 mcm
800A	3	80" (2032) (1095)	48" (1219) (873)	22" (559) (330)	1540 lbs	3	#2 - 500 mcm
800A	4	80" (2032)(1222)	48" (1219) (960)	22" (559) (368)	1584 lbs	3	#2 - 500 mcm
1000A	3	80" (2032) (1171)	48" (1219) (922)	22" (559) (368)	1555 lbs	4	#4 - 500 mcm
1000A	4	80" (2032) (1222)	48" (1219) (960)	22" (559) (368)	1614 lbs	4	#4 - 500 mcm
1200A	3	80" (2032) (1222)	48" (1219) (960)	22" (559) (368)	1555 lbs	5	#4 - 500 mcm
1200A	4	80" (2032) (1603)	48" (1219) (1036)	22" (559) (368)	1614 lbs	5	#4 - 500 mcm

1 Enclosure dimensions are for reference. (DO NOT USE FOR CONSTRUCTION).

2 All cable connections suitable for copper or aluminum.

3 Enclosure depth shown has cable entry/exit location restrictions. Contact Factory for further detailed information.

* Enclosures painted ASA #61 Gray.

* See last page for attribution.

STANDARD FEATURES

- 2.3" back-lit LCD display for monitoring 3 Phase Utility/Generator voltage, system frequency, operation status and alarms
- Five key menu navigation
- Front panel editing with PIN protection
- Load on Utility & Load on Generator indication
- Utility & Generator Source available indication
- 3 Phase Voltage sensing on Utility & Generator Sources
- Generator AC frequency sensing
- Utility under voltage control setpoint 50 - 95%¹
- Generator under voltage control setpoint 50 - 95%¹
- Generator under frequency control setpoint 70 - 90%¹
- Engine warmup timer 0-60 min.¹
- Utility return timer 0-60 min.¹
- **Engine start (Mains Transient) timer 0-30 sec.¹**
- Engine cooldown timer 0-60 min.¹
- Neutral position delay timer 0-300 sec.¹
- Load Disconnect Contact (LDC) for pre/post transfer control to signal external building systems such as elevators during transfer operations
- Up to 16 different date and time scheduler for On-load or Off-load Generator Exercising
- Real-time clock provides accurate event logging
- Data logging
- Ten outputs total. Two user programmable outputs are rated at 2A, 24VDC resistive, and two user programmable output rated 15A, 24VDC resistive. Remaining contacts are for ATS functionality. The user programmable outputs can be changed to 20 different functions including: Load on Utility, Load on Gen, Load Disconnect Contact (LDC), Fail to Transfer (FTT), Utility Power Available (UPA), Generator Power Available (GPA), Utility Power Fail, ATS Not in Auto, and ATS in Auto.
- The Transfer Switch is pre-programmed with the following outputs enabled:
 - Load on Utility (UX) (15A)
 - Load on Gen (GX) (15A)
 - Load Disconnect Contact (LDC) (8A)
 - Fail to Transfer (FTT) (2A)
 - ATS Not in Auto (NIA) (2A)

¹ Settings are adjustable

² Power Metering requires Current Transformer Option Kit.



- Local and Remote utility power fail simulation test
- Engine start contact (8A, 120/240VAC resistive max.)
- Automatic force transfer to alternate supply should load voltage become de-energized
- 24VDC control power
- Remote Load Test/Peak Shave Input
- Solid Neutral on 4 Wire Systems
- Configuring System Voltage Type (3 wire delta or 4 wire Wye capable without additional sensing transformers)
- ATS Generator Bus Power Metering Capability (Amp, Volt, Freq, kW, kVA, PF)²
- Under/Over Frequency Protection - Utility and Generator Sources
- 3 Phase Over Voltage Protection - Utility and Generator Sources
- Phase Sequence and Phase Rotation Protection between Utility and Generator Sources
- Voltage Phase Loss/Unbalance Protection
- Fourteen Programmable Inputs Total (Quantity 5 User Programmable Inputs)
- Optional Remote Input module DSE2130 (Quantity 8) Digital inputs
- Optional Remote Output module DSE2157 (Quantity 8) relay contacts
- RS485 Modbus[®]* Remote Communication Port (Modbus Serial RTU)
- Optional Ethernet Modbus TCP/IP[®] Remote Communication Module DSE855 (Modbus TCP/IP)
- Optional Remote Annunciator
- Support up to Three Remote Display Unit
- Serviceable Plug-in connectors

* See last page for attribution.

TS 870 ORDERING INFORMATION

When placing an order, specify the following 21 digit ATS MODEL CODE as per the features and applications described below.

1 2 3 4 5 6 7 8 9 10 11 12 13 14 15 16 17 18 19 20 21

T S

8	7																		
---	---	--	--	--	--	--	--	--	--	--	--	--	--	--	--	--	--	--	--

1-3. SERIES

TS - TRANSFER SWITCH

4 & 5. MODEL

87 - 870 SWITCH

6. POLES

2 - 2 POLE

3 - 3 POLE

4 - 4 POLE

7. CONFIGURATION TYPE

A - ATS

E - DOUBLE BYPASS - 4 BRKR⁹

X - SPECIAL

8 - 11. AMPERAGE

0100

0150

0200⁵

0250

0400

0600

0800

1000

1200

12. APPLICATION

A - STANDARD

B - SERVICE ENTRANCE

C - DUAL UTILITY CONTROL

D - DUAL STANDBY GEN (Slave ATS)

H - DUAL PRIME GEN CONTROL

X - SPECIAL

13. OPERATION TYPE

1 - OPEN TRANSITION

2 - MANUAL ELEC. OP.

3 - CLOSED TRANSITION (MOMENTARY)⁷

X - SPECIAL

14. SAFETY STANDARD

A - UL™ 1008 (Service Entrance)

B - CSA™ C22.2 NO 178

C - UL 1008 / CSA 178

X - NOT APPLICABLE

15. VOLTAGE

1Ø 3 WIRE

D - 120/240

3Ø 4 WIRE (GROUNDED NEUTRAL)

E - 120/208¹

F - 127/220

G - 120/240¹ (DELTA)

H - 220/380²

S - 230/400²

J - 240/416

K - 254/440

M - 277/480¹

N - 347/600¹

Y - MULTI-VOLTAGE (STOCK SWITCHES Only)¹ *Customer Configurable*

16. CONTROLLER

5 - TSC 900 c/w GHC GRAPHIC DISPLAY

6 - TSC 7320 c/w LCD DISPLAY

7 - NONE (MANUAL)

17. ENCLOSURE TYPE

A - NEMA1, ASA #61 GRAY

B - NEMA2, ASA #61 GRAY

C - NEMA12, ASA #61 GRAY

D - NEMA3R SD, ASA #61 GRAY

E - NEMA3R DD, ASA #61 GRAY

F - NEMA3RX / 4X DD (304 STAINLESS STEEL)³

G - NONE (OPEN STYLE)

L - NEMA3RX / 4X DD (316 STAINLESS STEEL)³

X - SPECIAL

18. UTILITY SWITCHING DEVICE

D - MOLDED CASE SWITCH DRAWOUT⁹ (400 - 1200A)

E - MOLDED CASE SWITCH DRAWOUT⁹ C/W ELECTRONIC TRIP (400 - 1200A)

F - MOLDED CASE SWITCH DRAWOUT⁹ C/W ELECTRONIC TRIP & GF (400 - 1200A)

K - MOLDED CASE SWITCH (100 - 1200A)

M - MOLDED CASE SWITCH C/W THER-MAG TRIP (100 - 200A)

N - MOLDED CASE SWITCH C/W ELECTRONIC TRIP (250 - 1200A)

P - MOLDED CASE SWITCH C/W ELECTRONIC & GF TRIP (250 - 1200A)

19. GENERATOR SWITCHING DEVICE

D - MOLDED CASE SWITCH DRAWOUT⁹ (400 - 1200A)

E - MOLDED CASE SWITCH DRAWOUT⁹ C/W ELECTRONIC TRIP (400 - 1200A)

F - MOLDED CASE SWITCH DRAWOUT⁹ C/W ELECTRONIC TRIP & GF (400 - 1200A)

K - MOLDED CASE SWITCH (100 - 1200A)

M - MOLDED CASE SWITCH C/W THER-MAG TRIP (100 - 200A)

N - MOLDED CASE SWITCH C/W ELECTRONIC TRIP (250 - 1200A)

P - MOLDED CASE SWITCH C/W ELECTRONIC & GF TRIP (250 - 1200A)

20. POWER CONNECTIONS

A - STANDARD

B - ATS CONNECTION PLATE 100-400A

C - ATS CONNECTION PLATE 600-800A

D - ATS CONNECTION PLATE 1000-1200A

E - ATS CONNECTION PLATE 100-400A FOR U&G

F - ATS CONNECTION PLATE 600-800A FOR U&G

G - ATS CONNECTION PLATE 1000-1200A FOR U&G

X - SPECIAL

21. ATS CONNECTION CONFIGURATION³

A - STANDARD

B - ALTERNATE B (400-1200A)

C - ALTERNATE C (400-1200A)

D - ALTERNATE D (400-1200A)

NOTES:

1 MULTI-VOLTAGE CAPABLE

2 FOR 50 Hz APPLICATION

3 FOR BYPASS SWITCH APPLICATIONS REFER TO FACTORY

5 240V MAX

7 CLOSED TRANSITION OPTION 400A - 1200A ONLY

9 DOUBLE BYPASS OPTION 400A - 1200A ONLY

AVAILABLE IN STOCK

The following standard ATS models are available from stock:

AMPERAGE	3 POLE	2 POLE OPTION (TS 872)	SERVICE ENTRANCE RATED ATS	SOLID NEUTRAL	MULTI VOLTAGE (CUSTOMER CONFIGURABLE 208-600V)	TSC 7320 CONTROLLER	NEMA@ 1 ENCLOSURE	NEMA 3R ENCLOSURE OPTION	4 PROGRAMMABLE OUTPUT CONTACTS (2A, 24VDC)	MODBUS™ RTU REMOTE COMMUNICATION PORT (SERIAL RS 485)
100A	Standard			Standard	Standard	Standard	Standard	Available Options In Stock	Standard	Standard
150A	Standard	Available Options In Stock		Standard	Standard	Standard	Standard	Available Options In Stock	Standard	Standard
200A	Standard	Available Options In Stock	Available Options In Stock	Standard	240V Max	Standard	Standard	Available Options In Stock	Standard	Standard
250A	Standard	Available Options In Stock	Available Options In Stock	Standard	Standard	Standard	Standard	Available Options In Stock	Standard	Standard
400A	Standard	Available Options In Stock	Available Options In Stock	Standard	Standard	Standard	Standard	Available Options In Stock	Standard	Standard
600A	Standard	Available Options In Stock	Available Options In Stock	Standard	Standard	Standard	Standard	Available Options In Stock	Standard	Standard
800A	Standard	Available Options In Stock	Available Options In Stock	Standard	Standard	Standard	Standard	Available Options In Stock	Standard	Standard

 Standard

 Available Options In Stock



* See last page for attribution.

OPTIONAL FEATURES (Specify separately from ATS MODEL CODE when ordering)

CODE	DESCRIPTION
<u>AUXILIARIES:</u>	
AUX-BG	Generator Bypass Auxiliary Contact
AUX-BU	Utility Bypass Auxiliary Contact
KOTS-DSE	Key Operated Test Switch - Auto/Off/Engine Start/Test - includes the DSE2130 module
RO2157	Programmable Relay Output Expansion Module - Includes QTY 8, 2A Resistive 30VDC rated relays - 4 NO and 4 Form C Contacts
PPR-10-DSE	Programmable Power Relay Includes 10A Form C Contact Wired to Terminal Block (Up to Qty 3)
TS-STG	24Vdc or 120VAC Shunt Trip Generator Switch (external power source required)
TS-STU	24Vdc or 120VAC Shunt Trip Utility Switch(external power source required)
<u>COMMUNICATION:</u>	
EMB-TCP/IP-DSE-MOXA	Ethernet Modbus®* Remote Communication (Modbus TCP)
RA7320 (DSE2548)	Remote annunciator with eight configurable LEDs. Works up to 0.6 miles from the TSC7320. Up to 10 modules can be daisy-chain (Refer to the DSE2548 Datasheet)
RD7320 (DSE2520)	Remote Display. Up to three display modules can be connected to TSC7320 (Refer to the DSE2510-20 Datasheet)
<u>ENCLOSURE:</u>	
LCK	Enclosure Lockable Door (Single point T-Handle lock)
TS-H1	Enclosure Strip Heater c/w Thermostat (120VAC external power source required)
TS-H2	Enclosure Strip Heater c/w Thermostat (internally powered from ATS load)
<u>FUNCTION:</u>	
MTS	Manually Initiated Electrically Operated Transfer Switch c/w Source Selector Switch, Position Indicating Lights, Source Available Lights
TCP	Transfer Switch Connection Plate for Generator Supply (Portable Generator Docking Supply)
TS-SS	Internal Multi-Voltage Selector Switch (208V/240V/480V)
LSC	Load Shed, 5 Stage - Requires CTK Option
<u>METERING:</u>	
LPM-DSE	Transfer Switch Load Power Metering CT Kit (Amp, Volt, Freq, kW, kVA, PF) **Requires CT Kit
CTKxxxx-DSE	Current Transformer Kit (xxxx - Specify CT Size 0100, 0150, 0250, 0400, 0600, 0800, 1200) - Requires CT Kit
MUP	Multifunction Utility Protective Relay – Basler®* BE1-11i (Protection Functions 27, 32, 47, 50/51, 67, 81O/U) NOTE: May be required by local utility for Momentary CT applications. Consult factory for other makes and models
<u>POWER:</u>	
SPD	Surge Protection Device
<u>OTHER:</u>	
3YR	Additional 12 Month Warranty **
5YR	Additional 48 Month Warranty **

* See last page for attribution.

** Refer to Thomson Technology Power Systems Warranty for additional details

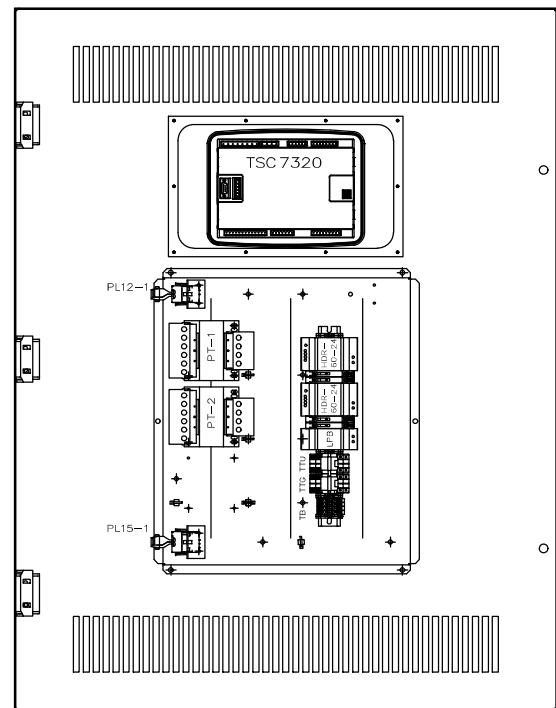
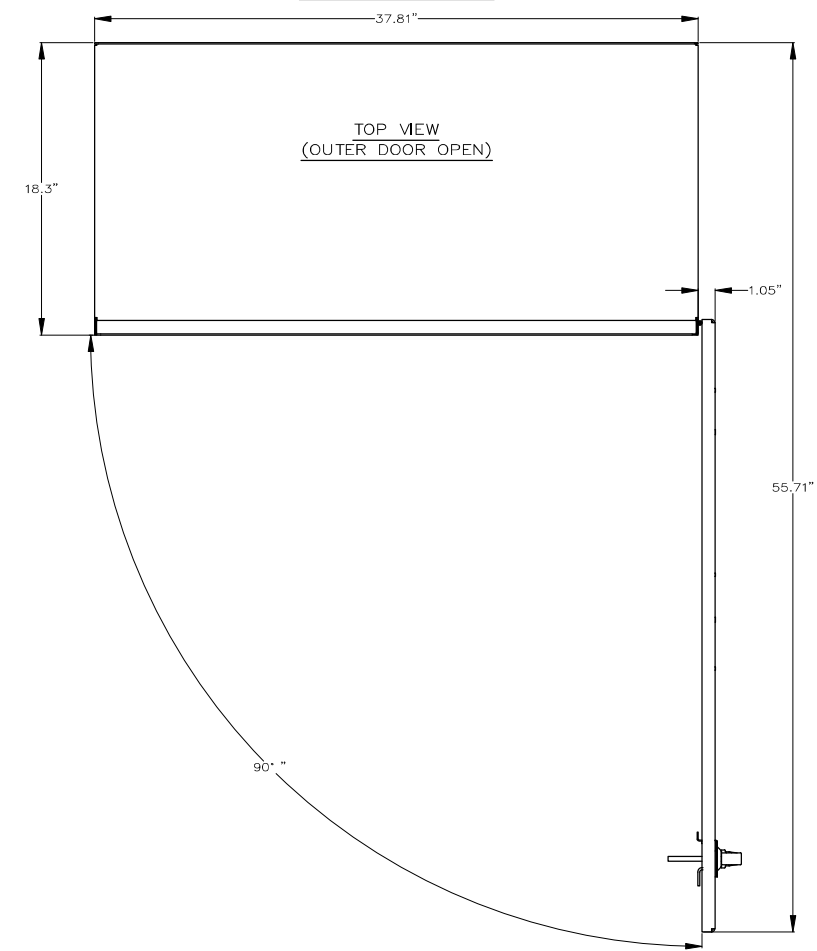
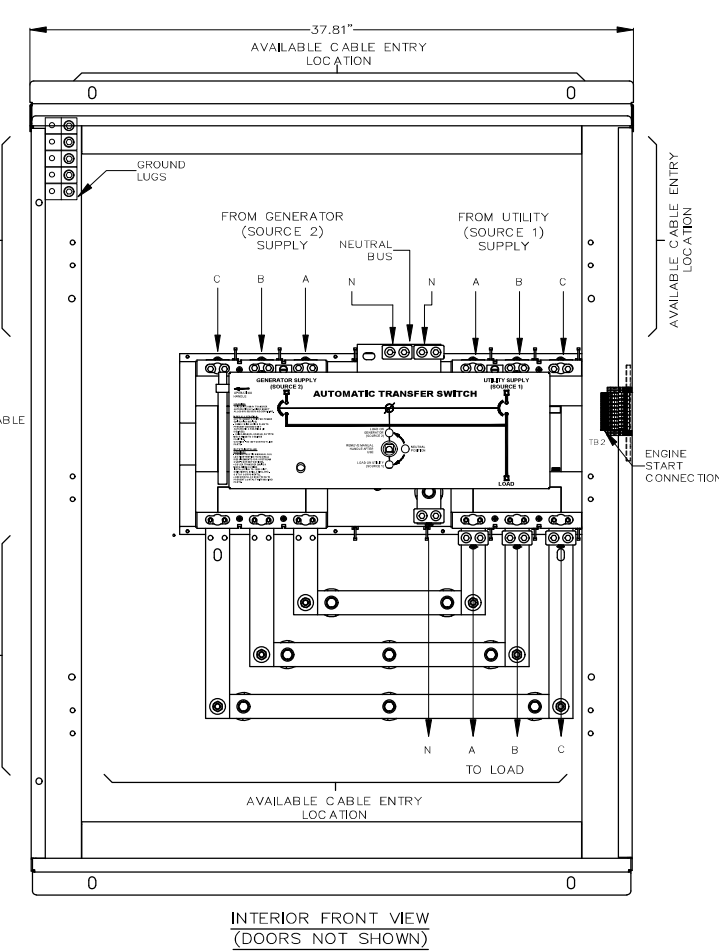
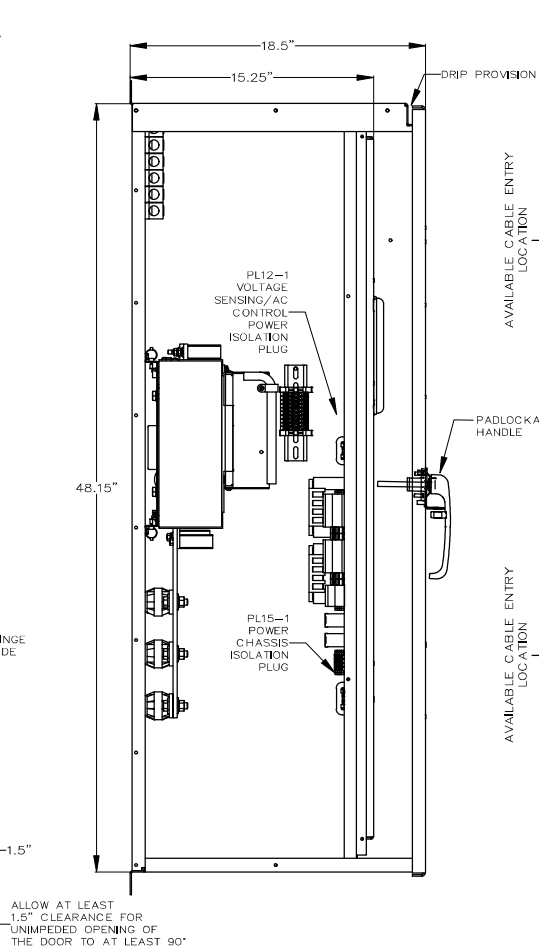
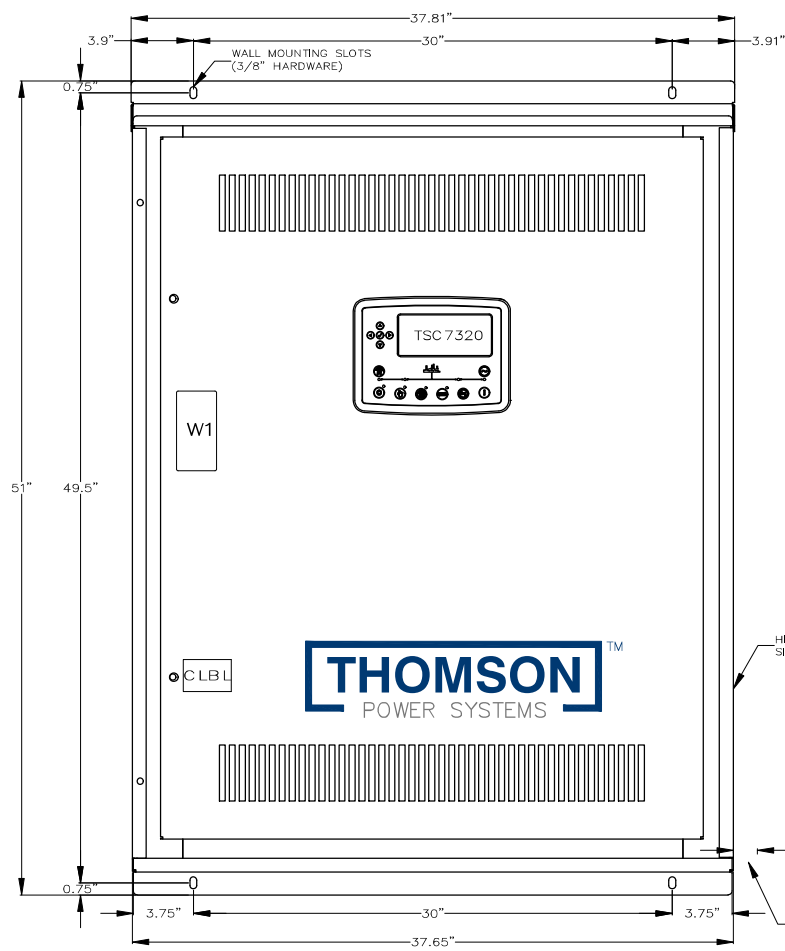

STANDARD ATS					
CLOSING AND WITHSTAND RATING AVAILABLE AMPS (RMS) CLOSING & WITHSTAND RATINGS SHOWN ARE ONLY FOR ATS UTILITY AND/OR GENERATOR POWER SWITCHING DEVICE(S) THAT ARE NOT FACTORY SUPPLIED WITH INTEGRAL OVERCURRENT PROTECTION. PLEASE REFER TO PRODUCT INSTRUCTION MANUAL FOR FURTHER INFORMATION ON UPSTREAM PROTECTION REQUIREMENT.					
MAX. VOLTAGE	RATED CURRENT (A)	@240V	@480V	@600V	
TS 87xA-400	600	400	65,000	50,000	35,000

CONNECTION DATA	
UTILITY (SRC1)	1-2C, 2/0-500MCM Cu/Al PER PHASE
GENERATOR (SRC2)	1-2C, 2/0-500MCM Cu/Al PER PHASE
LOAD	1-2C, 2/0-500MCM Cu/Al PER PHASE
NEUTRAL	1-2C, 2/0-500MCM Cu/Al PER SOURCE
GROUND	6C, #6-250MCM Cu/Al

- GENERAL NOTES
- POWER SWITCHING DEVICES ARE MECHANICALLY INTERLOCKED SO THAT ONLY ONE DEVICE IS CLOSED AT A TIME
 - FOR 1 PHASE, 3 WIRE SOLID NEUTRAL APPLICATION, CONNECT PHASE TO 'A' & 'B'. OMIT 'C'
 - FOR 1 PHASE, 3 WIRE SWITCHED NEUTRAL APPLICATION, CONNECT PHASE TO 'A' & 'B'. CONNECT NEUTRAL TO 'C'
 - REFER COVER PAGE / SELECTED OPTION LIST FOR PROJECT SPECIFIC DETAILS

2.5' x 5'

⚠ DANGER PELIGRO

Arc Flash and Shock Hazard
Will cause severe injury or death. Wear the correct PPE - see diagram. Disconnect all sources of supply before servicing. This equipment must be installed and serviced only by qualified electrical personnel following safe work practices and appropriate Personal Protective Equipment (PPE). Failure to comply may result in injury or death! Refer to NFPA 70E for minimum PPE requirements.

Risque d'Arc Electrique et d'Electrocution
Peut causer des blessures graves ou la mort. Plus d'un circuit sous tension - voir schéma. Couper toutes les sources d'alimentation avant de faire l'entretien et les réparations. Ce matériel doit être installé et entretenu uniquement par un électricien qualifié. Ce dernier doit connaître les pratiques de travail sécuritaires et porter l'équipement de protection individuelle approprié. Le non respect peut entraîner des blessures ou la mort! Reportez-vous à NFPA 70E pour le manuel des exigences minimales PPE.

Riesgo de Arco y Choque Eléctrico
Se causarán lesiones graves o muerte. Más de un circuito energizado - ver diagrama. Desconectar todas las fuentes de suministro antes de hacer mantenimiento. Este equipo solo se debe instalar y mantener por personal calificado, usando medidas de seguridad y equipo de protección personal adecuados. No seguir estas recomendaciones puede causar lesiones o muerte! Consultar la NFPA 70E para los requisitos mínimos del equipo de protección personal (PPE).

QTY = 1

APPROVED FOR CONSTRUCTION
 MASTER COPY REFERENCE COPY OF _____
 MULTIPLE UNIT WORK ORDER
 RELEASED FOR INFORMATION
 AUTH. BY: _____ DATE: _____

CROSS REFERENCE LEGEND	
50C-C-1	GRID COORDINATE
	SHEET No.
DRAWING No.	REFERENCE DRAWINGS No.
REVISIONS	BY/AUTH DATE



AUTOMATIC TRANSFER SWITCH
 MODEL TS 870
 PHYSICAL LAYOUT & INSTALLATION DETAILS
 400A, 2P/3P, NEMA 3R DD, MCS ATS, STD

FOR REVIEW ONLY

DRAWINGS AND/OR OTHER TECHNICAL INFORMATION SUPPLIED BY THOMSON POWER SYSTEMS AS A PART OF A SALE OF EQUIPMENT ARE FOR THE PURCHASER'S USE SOLELY IN CONJUNCTION WITH THAT EQUIPMENT, UNLESS SPECIFICALLY AGREED TO OTHERWISE AS A PART OF THE TERMS OF SALE.			
CUSTOMER ORDER No. C-XXXXXX		THOMSON POWER SYSTEMS	
CUSTOMER ORDER No. W-XXXXXX	WORK ORDER No. W-XXXXXX	DATE	REV
DRAWN BY SK	AUTH BY OG	23-02-07	0
DRAWING/FILE No. MCS870M326	SHEET	10A	

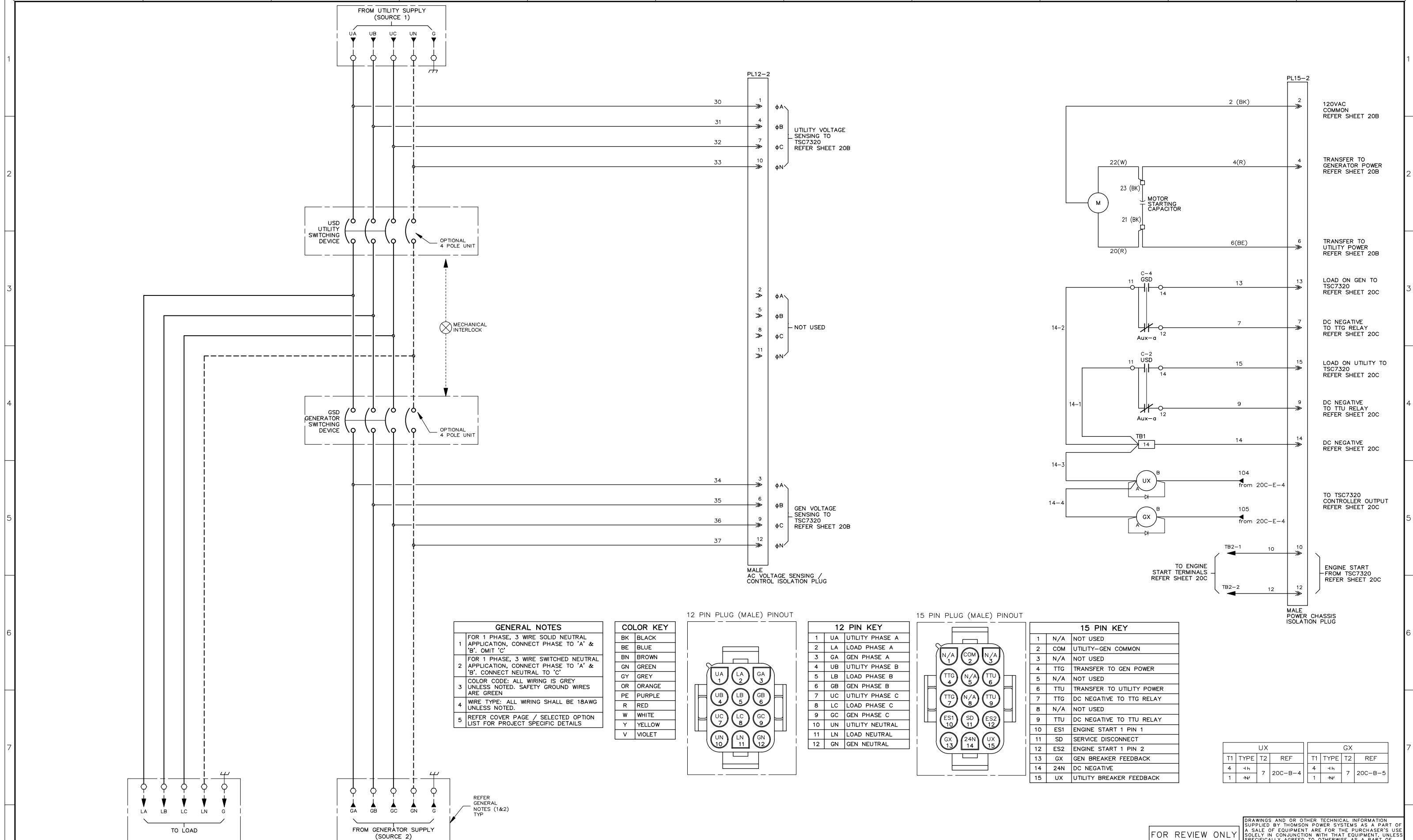

- GENERAL NOTES**
- FOR 1 PHASE, 3 WIRE SOLID NEUTRAL APPLICATION, CONNECT PHASE TO 'A' & 'B'. OMIT 'C'
 - FOR 1 PHASE, 3 WIRE SWITCHED NEUTRAL APPLICATION, CONNECT PHASE TO 'A' & 'B'. CONNECT NEUTRAL TO 'C'
 - COLOR CODE: ALL WIRING IS GREY UNLESS NOTED. SAFETY GROUND WIRES ARE GREEN
 - WIRE TYPE: ALL WIRING SHALL BE 18AWG UNLESS NOTED.
 - REFER COVER PAGE / SELECTED OPTION LIST FOR PROJECT SPECIFIC DETAILS

COLOR KEY

BK	BLACK
BE	BLUE
BN	BROWN
GN	GREEN
GY	GREY
OR	ORANGE
PE	PURPLE
R	RED
W	WHITE
Y	YELLOW
V	VIOLET

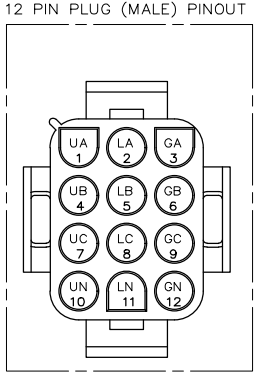

12 PIN KEY

1	UA	UTILITY PHASE A
2	LA	LOAD PHASE A
3	GA	GEN PHASE A
4	UB	UTILITY PHASE B
5	LB	LOAD PHASE B
6	GB	GEN PHASE B
7	UC	UTILITY PHASE C
8	LC	LOAD PHASE C
9	GC	GEN PHASE C
10	UN	UTILITY NEUTRAL
11	LN	LOAD NEUTRAL
12	GN	GEN NEUTRAL

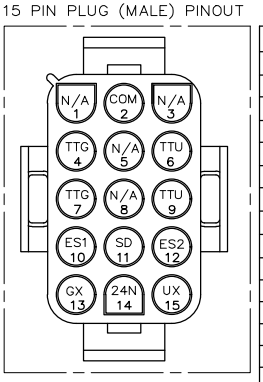

15 PIN KEY

1	N/A	NOT USED
2	COM	UTILITY-GEN COMMON
3	N/A	NOT USED
4	TTG	TRANSFER TO GEN POWER
5	N/A	NOT USED
6	TTU	TRANSFER TO UTILITY POWER
7	TTG	DC NEGATIVE TO TTG RELAY
8	N/A	NOT USED
9	TTU	DC NEGATIVE TO TTU RELAY
10	ES1	ENGINE START 1 PIN 1
11	SD	SERVICE DISCONNECT
12	ES2	ENGINE START 1 PIN 2
13	GX	GEN BREAKER FEEDBACK
14	24N	DC NEGATIVE
15	UX	UTILITY BREAKER FEEDBACK

UX				GX			
T1	TYPE	T2	REF	T1	TYPE	T2	REF
4	-h	7	20C-B-4	4	-h	7	20C-B-5
1	-h			1	-h		

APPROVED FOR CONSTRUCTION
 MASTER COPY REFERENCE COPY _____ OF _____
 MULTIPLE UNIT WORK ORDER
 RELEASED FOR INFORMATION
 AUTH. BY: _____ DATE: _____

CROSS REFERENCE LEGEND

50C-C-1	GRID COORDINATE
	SHEET No.
	DRAWING No.
	REFERENCE DRAWINGS No.

REVISIONS

5	15 PIN PLUG (MALE) PINOUT UPDATED	SN	OG	23-03-15
4	UPDATED WIRE NUMBERS	SK	OG	23-01-30
3	UPDATED 24VDC NEGATIVE WIRE NUMBERS & UX, GX RELAYS	SK	OG	23-01-25
2	ADDED RELAYS FOR LOAD ON GEN AND LOAD ON UTILITY	SK	OG	23-01-11
1	UPDATED DRAWINGS AS PER PROTO TYPE MODIFICATIONS	SK	OG	22-12-08



AUTOMATIC TRANSFER SWITCH
 MODEL TS 870
 MCS ATS AC SCHEMATIC, STD
 100 - 800A

FOR REVIEW ONLY

CUSTOMER THOMSON POWER SYSTEMS

CUSTOMER ORDER No. C-XXXXXX	WORK ORDER No. W-XXXXXX
DRAWN BY SK	AUTH BY OG
DATE 22-11-22	REV 5
DRAWING/FILE No. MCS870E500	SHEET 20A

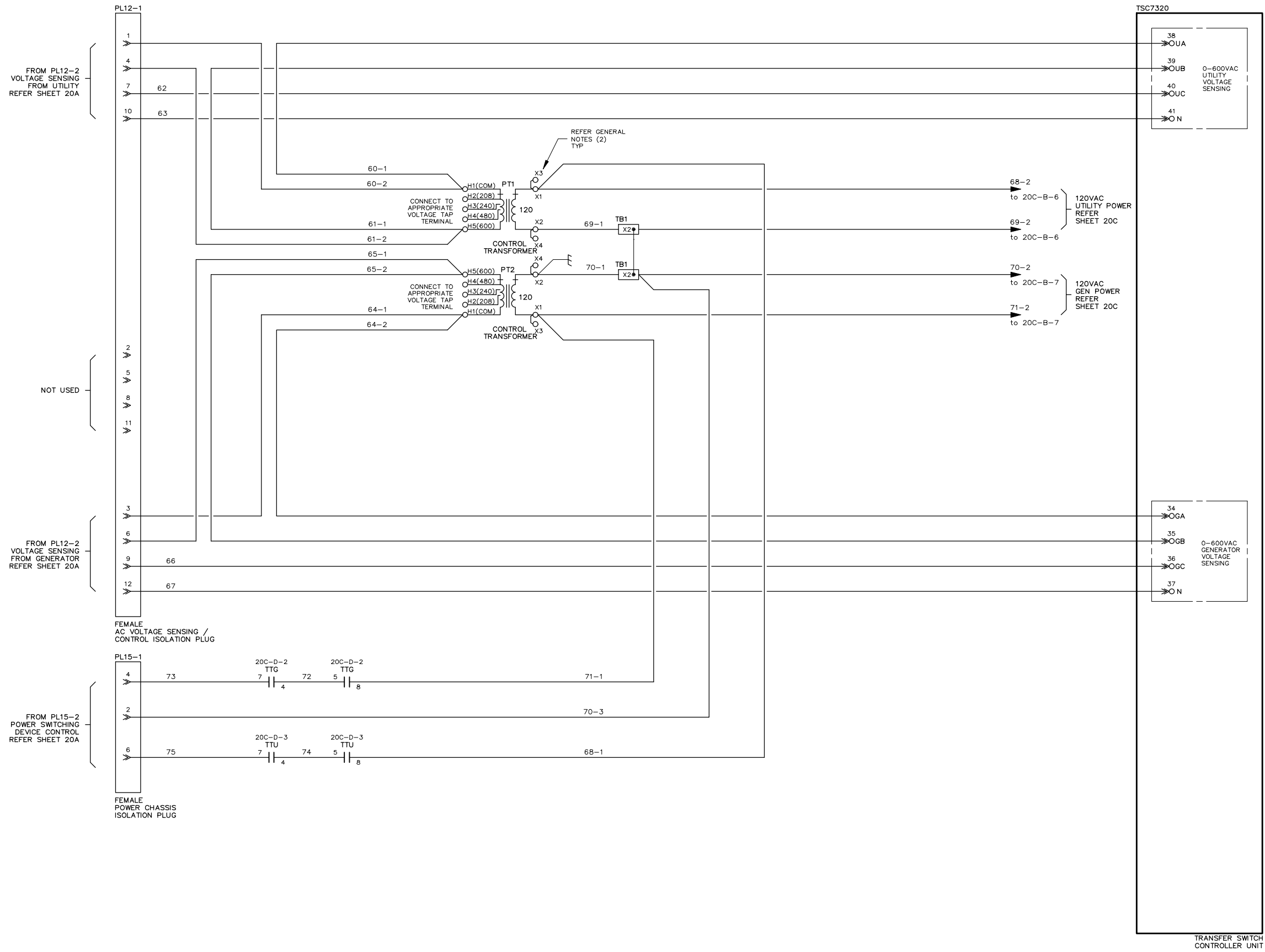

VOLTAGE
(X DENOTES HIGH POLARITY MARKER)

PT TAP	208	240	380	400	416	480	600
H1	X	X	X	X	X	X	X
H2	X	X	X	X	X	X	X
H3	X	X	X	X	X	X	X
H4	X	X	X	X	X	X	X
H5	X	X	X	X	X	X	X

- GENERAL NOTES**
- CONTROL TRANSFORMER IS RATED FOR 100VA FOR MCS ATS & 200VA FOR ATS MECHANISM USING TRIP & CLOSE COILS
 - 100VA CONTROL TRANSFORMER DOES NOT INCLUDE A 2ND 120VAC SECONDARY WIRING (X3/X4)
 - COLOR CODE: ALL WIRING IS GREY UNLESS NOTED. SAFETY GROUND WIRES ARE GREEN UNLESS NOTED.
 - WIRE TYPE: ALL WIRING SHALL BE 18AWG UNLESS NOTED.
 - REFER COVER PAGE / SELECTED OPTION LIST FOR PROJECT SPECIFIC DETAILS

COLOR KEY

BK	BLACK
BE	BLUE
BN	BROWN
GN	GREEN
GY	GREY
OR	ORANGE
PE	PURPLE
R	RED
W	WHITE
Y	YELLOW
V	VIOLET

APPROVED FOR CONSTRUCTION
 MASTER COPY REFERENCE COPY ____ OF ____
 MULTIPLE UNIT WORK ORDER
 RELEASED FOR INFORMATION
 AUTH. BY: _____ DATE: _____

CROSS REFERENCE LEGEND
 50C-C-1
 GRID COORDINATE
 SHEET No.

No.	REVISIONS	BY	DATE
2	ADDED RELAYS FOR LOAD ON GEN AND LOAD ON UTILITY	SK OG	23-01-11
1	UPDATED DRAWINGS AS PER PROTO TYPE MODIFICATIONS	SK OG	22-12-08



**AUTOMATIC TRANSFER SWITCH
 TSC7320 TRANSFER SWITCH CONTROLLER
 ATS AC CONTROL SCHEMATIC, STD**
 100-800A

FOR REVIEW ONLY

CUSTOMER THOMSON POWER SYSTEMS	
CUSTOMER ORDER No. C-XXXXXX	WORK ORDER No. W-XXXXXX
DRAWN BY SK	AUTH BY OG
DATE 22-11-22	REV 2
DRAWING/FILE No. TSC700E100	SHEET 20B

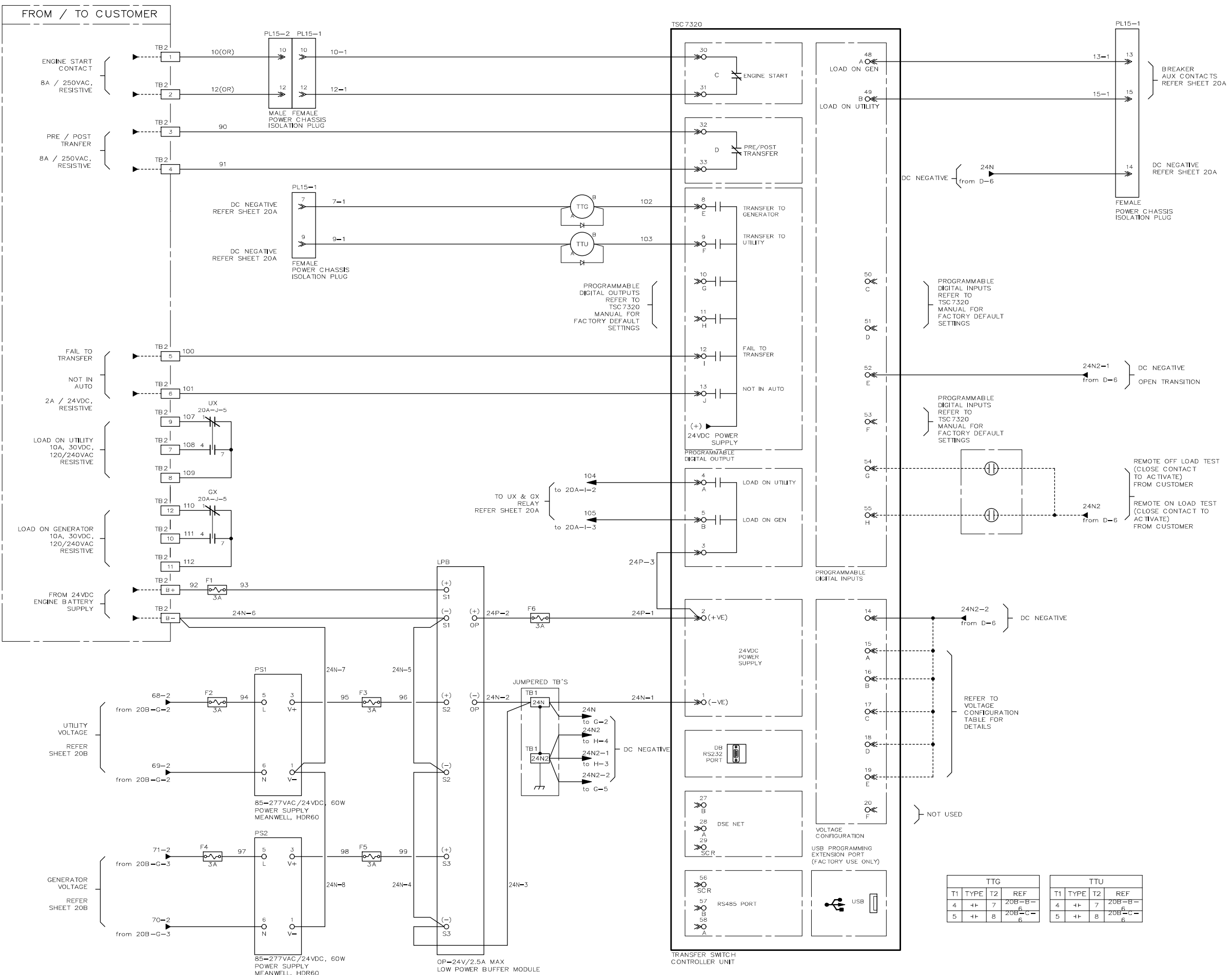

DSE7320 MKII FACTORY DEFAULT SETTINGS

NOTE: REFER TO OPTION DRAWINGS FOR APPLICABLE CHANGES TO FACTORY DEFAULT SETTINGS

PARAMETER	DEFAULT	RANGE
GENERATOR (SOURCE 2) START DELAY	3 SEC	0-60 SEC
GENERATOR (SOURCE 2) WARM UP DELAY	2 SEC	0-3600 SEC
GENERATOR (SOURCE 2) COOL DOWN DELAY	300 SEC	0-3600 SEC
UTILITY (SOURCE 1) RETURN DELAY	300 SEC	0-3600 SEC
TRANSFER NEUTRAL DELAY	3 SEC	0-120 SEC
TRANSFER FAIL DELAY	30 SEC	0-120 SEC
EXERCISE TIMER	PROG.	PROG.
GENERATOR (SOURCE 2) UNDER VOLTAGE DELAY	3 SEC	0-10 SEC
GENERATOR (SOURCE 2) UNDER FREQUENCY DELAY	5 SEC	0-10 SEC
GENERATOR (SOURCE 2) UNDER VOLTAGE PICK UP	90%	75-100%
GENERATOR (SOURCE 2) UNDER VOLTAGE DROP OUT	85%	70-95%
UTILITY (SOURCE 1) UNDER VOLTAGE DELAY	1 SEC	0-10 SEC
UTILITY (SOURCE 1) UNDER VOLTAGE PICK UP	90%	75-100%
UTILITY (SOURCE 1) UNDER VOLTAGE DROP OUT	85%	70-95%

ALL SETTINGS ARE FIELD ADJUSTABLE UNLESS NOTED. REFER TO THE DSC7320 MKII MANUAL FOR A COMPLETE LISTING OF ALL DSC7320 MKII SETTINGS.

VOLTAGE CONFIGURATION

I-#	INPUT FUNCTION	VOLTAGE CONFIGURATION
I-14	DEFAULT	480V, 3PH 4W
I-15	INPUT A	120/240V, 1PH 3W
I-16	INPUT B	208V, 3PH 4W
I-17	INPUT C	240V, 3PH 4W
I-18	INPUT D	600V, 3PH 4W
I-19	INPUT E	110V, 1PH 2W

PLEASE REFER TO THE TSC870 OPERATING MANUAL FOR THE TSC7320 CONTROLLER

GENERAL NOTES

- COLOR CODE: ALL WIRING IS GREY UNLESS NOTED. SAFETY GROUND WIRES ARE GREEN
- WIRE TYPE: ALL WIRING SHALL BE 18AWG UNLESS NOTED.
- REFER COVER PAGE / SELECTED OPTION LIST FOR PROJECT SPECIFIC DETAILS
- ANALOG INPUT GROUND CONNECTIONS MUST BE ON THE ENGINE BLOCK AND MUST BE TO THE SENSOR BODIES.

COLOR KEY

BK	BLACK
BE	BLUE
BN	BROWN
GN	GREEN
GY	GREY
OR	ORANGE
PE	PURPLE
R	RED
W	WHITE
Y	YELLOW
V	VIOLET

TTG

T1	TYPE	T2	REF
4	4+	7	20B-B-
5	4+	8	20B-C-

TTU

T1	TYPE	T2	REF
4	4+	7	20B-B-
5	4+	8	20B-C-

APPROVED FOR CONSTRUCTION
 MASTER COPY REFERENCE COPY OF _____
 MULTIPLE UNIT WORK ORDER
 RELEASED FOR INFORMATION
 AUTH. BY: _____ DATE: _____

CROSS REFERENCE LEGEND

50C-C-1	GRID COORDINATE	SHEET No.	DRAWING No.	REFERENCE DRAWINGS

REVISIONS

No.	DESCRIPTION	BY	DATE
6	UPDATED VOLTAGE CONFIGURATION DETAILS	SK	23-01-30
5	UPDATED 24VDC NEGATIVE WIRE NUMBERS & UX, GX RELAYS	SK	23-01-24
5	UPDATED DIGITAL INPUT 52(E) & UX, GX FORM-C CONTACT RATING	SK	23-01-23
3	ADDED CONTACTS FOR UX & GX, REMOTE INPUT LABELS	NH	23-01-12
2	ADDED RELAYS FOR LOAD ON GEN AND LOAD ON UTILITY	SK	23-01-11



**AUTOMATIC TRANSFER SWITCH
 TSC7320 TRANSFER SWITCH CONTROLLER
 ATS DC CONTROL SCHEMATIC, STD**
 100 - 800A

FOR REVIEW ONLY

CUSTOMER THOMSON POWER SYSTEMS

CUSTOMER ORDER No. C-XXXXXX	WORK ORDER No. W-XXXXXX
DRAWN BY SK	DATE 22-11-22
AUTH BY OG	REV 6
DRAWING/FILE No. TSC700E101	SHEET 20C

TWO YEAR LIMITED WARRANTY

**Models: TS 880, TS 870, TS 840,
TS 970, TS 930, QCP
and 3PTS**



1. **LIMITED WARRANTY**

This warranty applies to new TS 880, TS 870, TS 840, TS 970, TS 930, QCP & 3PTS series ("Product") manufactured by Thomson Technology Power Systems ULC dba Thomson Power Systems.

Thomson Power Systems warrants that it will repair or replace, at Thomson Power Systems sole discretion, any Product that proves to have a defect in material or workmanship during the time period of effectiveness of this limited warranty, provided that initial inspection and start-up of the installation are conducted by qualified personnel.

Any parts or equipment that the purchaser/owner claims to be defective must be returned to Thomson Power Systems. Repair, replacement or appropriate adjustment will be made upon examination, inspection and testing by Thomson Power Systems, if the part is determined to be defective under normal use.

Time limitations of Limited Warranty

This coverage shall become effective upon the date of product shipment from Thomson Power Systems and shall expire 24 months thereafter.

Extended Limited Warranty Coverage

At the Buyers election warranty protection can be extended as follows:

- 3 year warranty – extended 12 months beyond the standard 24 months from date of shipment.
- 5 year warranty – extended 36 months beyond the standard 24 months from date of shipment.

This option is available for purchase within the first 12 months of the warranty period.

2. **THOMSON POWER SYSTEMS'S RESPONSIBILITIES UNDER THE LIMITED WARRANTY**

Thomson Power Systems shall be responsible for:

- A) The repair or replacement, at Thomson Power Systems election, of defective Products, which are eligible under this warranty. Any labour associated with the warranty procedure shall be provided by Thomson Power Systems or its Authorized Service Representative (ASR), to a maximum of four (4) hours. In the event that labour on site may exceed this maximum time allowable, additional charges must be authorized by Thomson Power Systems.
- B) Travel time and mileage expenses covered by this limited warranty are limited to a maximum of four (4) hours **regular** time labour and 200 kilometers (125 miles). Any expenses in excess of this maximum allowance shall be to the account of the Owner, and will be charged at Thomson Power Systems standard rates (per Thomson Power Systems Price List PL017). In the event that an ASR performs the work, expenses in excess of this maximum allowance shall be to the account of the Owner, paid to the ASR charged at their applicable rates.
- C) In the event that an ASR performs the work, costs for one technician only will be covered under this warranty. Multiple technicians may be eligible for coverage only if preauthorized by Thomson Power Systems prior to the performance of the service work.
- D) In the event that an ASR performs the work, costs for one occurrence per claim will be covered under this warranty. Additional costs for repeat attendances to



correct the same deficiency/problem may be eligible for coverage only if preauthorized by Thomson Power Systems prior to the repeat of the service work.

- E) For warranty consideration or approval, claims must be submitted to Thomson Power Systems within one (1) week of warranty procedure site work.
- F) Whenever possible, reasonable measures must be made to notify Thomson Power Systems and perform remote technical troubleshooting at the earliest opportunity.

3. OWNER'S RESPONSIBILITIES UNDER THE LIMITED WARRANTY

Owner shall be responsible for:

- A) Proper operation and maintenance of the Product.
- B) Maintaining a detailed record of all maintenance or system repairs performed.
- C) Making the warranted Product available to Thomson Power Systems or its designated ASR for warranty repair, during normal business hours.
- D) Any labour charge differential incurred for overtime labour. Overtime labour charge differential shall be the difference between Thomson Power Systems regular and overtime rates.
- E) Any costs incurred as the result of the removal or reinstallation of the Products or Systems undertaken by the Owner or the Owner's representative.
- F) Any administrative costs borne by the Owner or the Owner's representative as a result of a warranted failure.
- G) All costs of transportation, lodging, meals (except those allowed in paragraph 2B) incurred by Thomson Power Systems.
- H) Returning all defective product to Thomson Power Systems for examination, inspection and testing. **All freight charges are at the Owner's expense.**

4. LIMITATION OF THOMSON POWER SYSTEMS'S OBLIGATIONS UNDER THE LIMITED WARRANTY

- A) The obligations of Thomson Power Systems under this limited warranty shall be voided, and Thomson Power Systems shall not be responsible for:
 - i) Failure resulting from improper handling, storage or installation.
 - ii) Failure resulting from Owner or operator abuse or neglect.
 - iii) Failure resulting from modifications or repairs not authorized by Thomson Power Systems in writing.
 - iv) Failure due to normal wear and tear, or as a result of lack of routine maintenance.
 - v) Damage due to negligent maintenance practices such as, but not limited to:

- a) Failure to turn off AC power to battery charger before disconnecting battery from the system.
 - b) Failure to disconnect all sources of power before servicing the Product.
 - c) Application of voltage source not suitable for the Product.
 - d) Use of wiring not suitable for the Product.
 - vi) Failure to perform scheduled maintenance such as required by regulatory authorities or as prescribed in product manuals.
 - vii) Failure attributed to abnormal voltage or current levels, including transients.
 - viii) Failure of Owner to provide written notice and details of a defect to Thomson Power Systems in a timely manner.
 - ix) Failure to make Products available to Thomson Power Systems or its ASR in a timely manner.
- B) Thomson Power Systems shall not be responsible for any administrative costs associated with the warranty procedure.
- C) Thomson Power Systems shall not be responsible for costs related to substitute or temporary equipment, which Owner provided in conjunction with the warranted repair.
- D) Thomson Power Systems shall not be responsible for any contingent costs related to failure of the Product, including damage to property and loss of use of property.

5. RETURN OF PRODUCTS UNDER LIMITED WARRANTY

No Product may be returned to Thomson Power Systems without prior written consent. Thomson Power Systems will not accept shipping charges, for the return of defective Product to its factory or authorized service outlet, or the return of repaired or replacement Product to the Owner. Return Material Authorization (RMA) Request form (SVF028) is available from our website at www.thomsonps.com.

Thomson Power Systems is not liable nor responsible for items returned without authorization. Delivery may be refused, or items disposed of without notice. Collect and COD shipments will be refused.

6. APPLICABILITY AND EXPIRATION OF LIMITED WARRANTY

The warranties set out above are extended to Owners of the Product.

The foregoing sets forth Thomson Power Systems only obligations and Owner's exclusive remedy for breach of warranty, whether such claims are based on breach of contract, tort (including negligence and strict liability), or other theories. The foregoing is expressly in lieu of other warranties whatsoever expressed, implied, or statutory, including without limitation, the implied warranties of merchantability and fitness.

Notwithstanding the preceding, Thomson Power Systems is not liable for any direct, special, incidental or consequential damages (whether denominated in contract, tort, strict liability, negligence or other theories) arising out of the use of any Products.

There is no other warranty.

TS 870

AUTOMATIC TRANSFER SWITCH WITH TSC 7320 CONTROLLER (OPEN & CLOSED TRANSITION)

INSTALLATION, OPERATING & SERVICE MANUAL

TABLE OF CONTENTS

1. PRODUCT REVISION HISTORY	4
2. EQUIPMENT STORAGE	4
2.1. EQUIPMENT STORAGE	4
2.2. EQUIPMENT OPERATING	5
3. NOTES TO INSTALLER	5
3.1. INSTALLATION CODES/PERMITS:	5
3.2. APPLICATION:	5
3.3. INSTALLATION LOCATION:	5
3.4. POWER CABLING:	5
3.5. CONTROL WIRING:	6
3.6. GENERATOR SET AUTOMATIC OPERATION:	6
3.7. LOAD TYPES:	6
3.8. UPSTREAM OVER CURRENT PROTECTION (NON-SERVICE ENTRANCE RATED TS 870):	6
3.9. UPSTREAM OVERCURRENT PROTECTION (SERVICE ENTRANCE RATED TS870):	6
3.10. WITHSTAND/INTERRUPTING CURRENT RATINGS:	7
3.11. TRANSFER SWITCHES WITH INTEGRAL OVER CURRENT PROTECTION	7
3.12. TRANSFER SWITCHES WITH MULTI-TAP VOLTAGE CAPABILITY	7
3.13. REMOTE START CONTACT FIELD WIRING	8
3.14. DIELECTRIC TESTING	8
3.15. INSTALLATION OF OPEN TYPE TRANSFER SWITCHES	8
3.16. SEISMIC ANCHORING	8
4. GENERAL DESCRIPTION	11
4.1. TSC 7320 ATS CONTROLLER	11
4.2. ATS POWER SWITCHING MECHANISM	12
4.3. PRODUCT MODEL CODE	14

4.4.	TYPICAL COMMISSIONING PROCEDURES	15
5.	AUTOMATIC SEQUENCE OF OPERATION	15
5.1.	STANDARD ATS - OPEN TRANSITION	15
5.2.	STANDARD ATS - CLOSED TRANSITION	16
5.3.	SERVICE ENTRANCE RATED ATS	20
5.4.	TEST MODES	24
6.	OVER CURRENT PROTECTION	26
6.1.	STANDARD TS 870 AUTOMATIC TRANSFER SWITCH	26
6.2.	OPTIONAL TS 870 AUTOMATIC TRANSFER SWITCH WITH INTEGRAL OVER CURRENT PROTECTION	26
7.	GENERAL NOTES ON SERVICING TRANSFER SWITCH MECHANISMS	27
8.	ATS MANUAL OPERATING INSTRUCTIONS	29
8.1.	TSC 7320 PUSH BUTTON CONTROLS FOR MANUAL OPERATION	29
8.2.	S-STYLE ATS - MANUAL OPERATION	31
8.3.	MO STYLE ATS -MANUAL OPERATION	33
9.	RECOMMENDED MAINTENANCE	38
10.	FRONT VIEW (TYPICAL) 3 / 4 POLE 100A-800A S-STYLE TRANSFER MECHANISM (MECHANISM FRONT COVER REMOVED)	39
11.	FRONT VIEW (TYPICAL) 3 / 4 POLE 1000A-1200A MECHANISM MOTOR OPERATOR (MO) STYLE TRANSFER MECHANISM	40
12.	CABLE TERMINAL INFORMATION	41
13.	REQUIREMENTS FOR UPSTREAM CIRCUIT PROTECTIVE DEVICES	42
13.1.	WITHSTAND CURRENT RATINGS (ALL MODELS WITHOUT INTEGRAL OVERCURRENT PROTECTION OPTION)	42
13.2.	INTERRUPTING CAPACITY CURRENT RATINGS (ALL MODELS WITH INTEGRAL OVERCURRENT PROTECTION OPTION)	43
14.	GROUND FAULT SITE TEST REQUIREMENTS	44
14.1.	PERFORMANCE TEST	44
15.	TROUBLESHOOTING	45

16. REPLACEMENT PARTS	50
17. PRODUCT RETURN POLICY	52
18. NOTES	53
19. PERFORMANCE TEST FORM	54
APPENDIX A – TYPICAL TS 870 ATS COMMISSIONING PROCEDURE	
APPENDIX B – TS 870 SYSTEM VOLTAGE CHANGE PROCEDURE	
APPENDIX C – SEISMIC CERTIFICATE	

1. PRODUCT REVISION HISTORY

The following information provides an historical summary of changes made to this product since the original release.

Operating & Service Manual Version

Rev 0 23/02/10	Original release.
-----------------------	-------------------

Contact Thomson Power Systems, to obtain applicable instruction manuals or if in doubt about any matter relating to installation, operation or maintenance. Soft copy of the most current version is available at www.thomsonps.com.

NOTE: All information contained in this manual is for reference only and is subject to change without notice.

Related Product Instruction Manuals

- TS 870 Quick Start Guide, PM173
- TSC 7320 Transfer Switch Controller, PM180

Contact Thomson Power Systems, to obtain these instruction manuals. Soft copy of the most current versions of these manuals are available at www.thomsonps.com.

2. EQUIPMENT STORAGE

The following procedures are required for correct storage of the transfer switch prior to installation.

CAUTION

Failure to store and operate equipment under the specified environmental conditions may cause equipment damage and void warranty.

2.1. EQUIPMENT STORAGE

The transfer switch shall be stored in an environment with a temperature range not exceeding -4° to $+158^{\circ}$ Fahrenheit (-20° to $+70^{\circ}$ Celsius) and a humidity range not exceeding 5%-95% non-condensing. Before storing, unpack sufficiently to check for concealed damage. If concealed damage is found, notify the ATS supplier and the Carrier immediately. Repack with the original, or equivalent packing materials. Protect from physical damage. Do not stack. Store indoors in a clean, dry, well ventilated area free of corrosive agents including fumes, salt and concrete/cement dust. Apply heat as necessary to prevent condensation.

2.2. EQUIPMENT OPERATING

The transfer switch shall be operated in an environment with a temperature range not exceeding +5° to +122° Fahrenheit (-15° to +50° Celsius) and a humidity range not exceeding 5%-95% non-condensing.

3. NOTES TO INSTALLER

DANGER

Arc Flash and Shock Hazard. Will cause severe injury or death.

Do not open equipment until ALL power sources are disconnected

This equipment must be installed and serviced only by qualified electrical personnel utilizing safe work practices and appropriate Personal Protective Equipment (PPE). Failure to do so may cause personal injury or death

3.1. INSTALLATION CODES/PERMITS:

Suitable permits are required by local authorities having jurisdiction prior to installing standby generator sets and automatic transfer switches.

3.2. APPLICATION:

The TS 870 Transfer Switch is Listed by Underwriters Laboratories (UL) to Safety Standard UL 1008 for Transfer Switches for Emergency Standby applications. This product is intended for installation and operation on legally required standby applications for emergency power systems as defined by the National Electrical Code (NEC).

3.3. INSTALLATION LOCATION:

The standard TS 870 transfer switch is designed for indoor wall mounting or outdoor wall mounting with NEMA 3R rating. The transfer switch must be installed in an environment where the temperature range is within +5° to +122° Fahrenheit (-15° to +50° Celsius) and humidity range not exceeding 5%-95% non-condensing.

NOTE: The transfer switch must not be installed in a location where it is subjected to direct sunlight on the front of the transfer switch door. In these applications, an optionally available sun-shade kit must be installed.

3.4. POWER CABLING:

All power cabling entering/exiting the enclosure must be installed in suitably sized conduit per NEC/CEC requirements. Ampacity, type and voltage rating of current carrying conductors must also comply with NEC/CEC requirements and local authorities having jurisdiction. To ensure satisfactory installation of this equipment, refer to manual [SECTION 12](#) Cable Terminal

Information regarding power cable connection tightness requirements. All mechanical and electrical connections must be checked for tightness prior to placing this equipment in service to ensure proper operation and to validate applicable warranty coverage.

3.5. CONTROL WIRING:

All control wiring for engine start, load shed, alarm and remote test must be installed in separate conduits from all power cabling and must utilize suitably sized conduits per NEC/CEC requirements. All control wiring shall be sized for minimum #18 AWG. Control wiring type and voltage rating must also comply with NEC/CEC requirements and local authorities having jurisdiction.

NOTE: All field wiring/communication cabling that may be field installed directly onto any ATS door mounted components must be suitably routed and protected across the door hinge to prevent possible mechanical damage upon door opening and/or door closing.

3.6. GENERATOR SET AUTOMATIC OPERATION:

The TS 870 transfer switch operates in conjunction with any generator set with remote automatic starting capabilities utilizing a 2 wire, remote start control contact input. A dry contact is provided for remote generator starting control (contact closes to start generator and opens to stop generator).

3.7. LOAD TYPES:

The standard TS 870 is suitable for control of motors, electric discharge lamps, tungsten filament lamps, and electric heating equipment where the sum of motor full-load ampere ratings and the ampere ratings of other loads do not exceed the ampere rating of the switch and the tungsten load does not exceed 30 percent of the switch rating.

3.8. UPSTREAM OVER CURRENT PROTECTION (NON-SERVICE ENTRANCE RATED TS 870):

Non-Service Entrance Rated TS 870 transfer switch models do not contain any integral over current protection and require upstream over current protection devices for both Utility and Generator sources.

3.9. UPSTREAM OVERCURRENT PROTECTION (SERVICE ENTRANCE RATED TS870):

Service Entrance rated TS 870 transfer switch models contain integral over current protection for the Utility source as standard. Service Entrance rated TS 870 transfer switches do not contain any integral over current protection for the generator source and requires upstream generator source over current protection. The Service Entrance rated TS 870 is rated for 80% maximum continuous loading of load types as described per [SECTION 3.7](#).

3.10. WITHSTAND/INTERRUPTING CURRENT RATINGS:

Refer to electrical ratings shown in [SECTION 13](#) for withstand/Interrupting current ratings. Short circuit currents listed for Standard type ATS are Withstand ratings. Short circuit currents listed for Service Entrance type ATS are Interrupting ratings based on the ratings of the supplied utility service disconnect circuit breaker utilized.

3.11. TRANSFER SWITCHES WITH INTEGRAL OVER CURRENT PROTECTION

For models of transfer switch with integral over current protection, the over current protection must be set prior to operation. The equipment will be shipped from the factory with a long-time current setting of 100% (of the equipment rating) and maximum short-time/instantaneous current and time delay settings.

WARNING

Do Not Energize this equipment until device settings have been verified to ensure proper system protection & coordination. Failure to do so may result in equipment failure.

Refer to **SECTION 5.3.2** of this manual for additional information on operation of the Transfer switch following an over current trip condition. Refer to information supplied with the transfer switch documentation package for adjustment procedures on the power switching units over current protection trip unit. Contact the factory if any additional information is required.

3.12. TRANSFER SWITCHES WITH MULTI-TAP VOLTAGE CAPABILITY

If the transfer switch has programmable multi-tap voltage capability (i.e. ATS Model Code with Voltage Code "Y"), confirm the transfer switch has been configured for the correct system voltage prior to installation.

WARNING

Failure to confirm and match transfer switch voltage with the system voltage could cause serious equipment damage.

The voltage selections and connections are shown on the drawings supplied with each transfer switch. The factory default settings will be indicated on the calibration label attached on the inside of the enclosure door (supplied loose on open style models). A blank label is included to record the applicable settings if the configuration is changed from the factory default settings.

To change the transfer switch voltage, refer to TS 870 System Voltage Change Procedure, Appendix B. Contact Thomson Power Systems for further information as may be required.

3.13. REMOTE START CONTACT FIELD WIRING

As a minimum, the remote engine start control field wiring shall conform to the local regulatory authority on electrical installations. Field wiring of a remote start contact from a transfer switch to a control panel should conform to the following guidelines to avoid possible controller malfunction and/or damage.

- 3.5.1.** Minimum #14 AWG (2.5mm²) wire size shall be used for distances up to 100ft (30m)¹. For distances exceeding 100 ft. (30m) consult Thomson Power Systems
- 3.5.2.** Remote start contact wires should be run in a separate conduit.
- 3.5.3.** Avoid wiring near AC power cables to prevent pick-up of induced voltages.
- 3.5.4.** An interposing relay may be required if field-wiring distance is excessively long (i.e. greater than 100 feet (30m)) and/or if a remote contact has a resistance of greater than 5.0 ohms.
- 3.5.5.** The remote start contact must be voltage free (i.e. dry contact). The use of a powered contact will damage the transfer controller.

3.14. DIELECTRIC TESTING

Do not perform any high voltage dielectric testing on the transfer switch with the TSC 7320 controller connected into the circuit as serious damage will occur to the controller. All AC fuses, DC control fuses and control circuit isolation plugs connected to the TSC 7320 must be removed if high voltage dielectric testing is performed in the transfer switch. Failure to isolate the TSC 7320 controller for dielectric testing can result in equipment malfunction and/or damage.

3.15. INSTALLATION OF OPEN TYPE TRANSFER SWITCHES

Please refer to the factory for additional information.

3.16. SEISMIC ANCHORING

Model TS870 Automatic Transfer Switches and Automatic Transfer and Bypass Isolation Switches in "standard" enclosures are seismic certified under AC156 building code for non-structural components.

Standard enclosures are all transfer switch enclosures Thomson Power Systems offers in NEMA 1, NEMA 2, NEMA 3R and NEMA 4X for the above listed product.

The transfer switch must be installed per the anchoring details provided for seismic qualification. The equipment can be mounted in alternate means and still qualify if a qualified Civil Engineer designs the alternate method of anchoring.

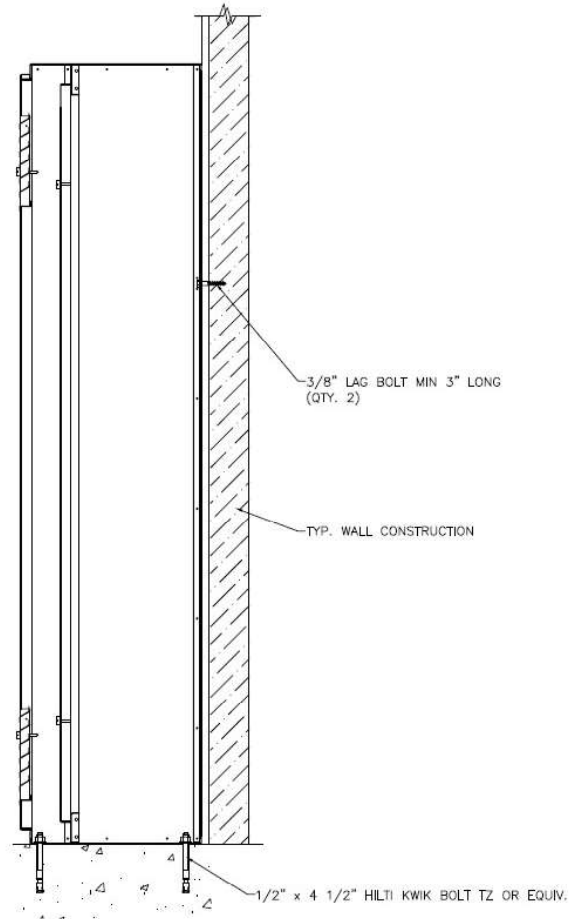

TYP. FLOOR/WALL ANCHORING
(REFER TO NOTE 5)

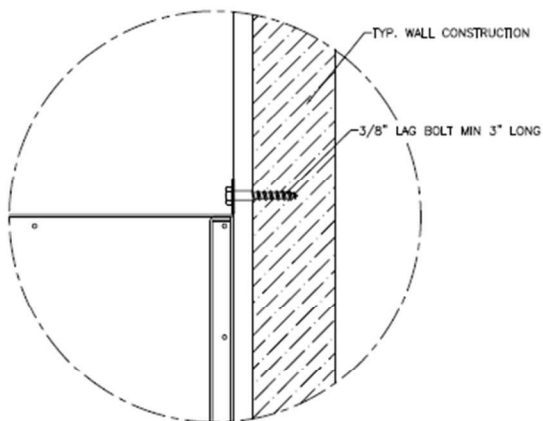

TYP. WALL ANCHORING

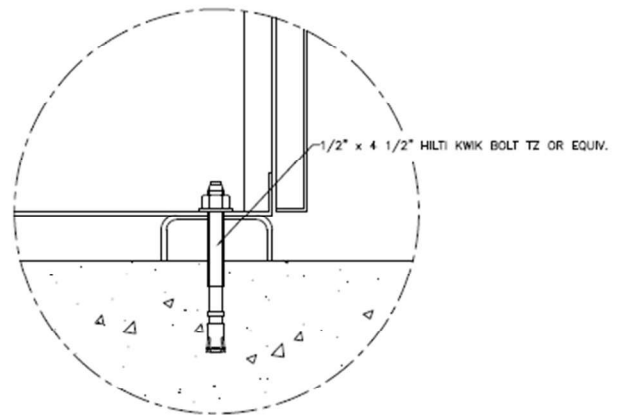

TYP. FLOOR ANCHORING

Anchoring Notes:

1. Anchoring must be designed according to IBC 2012 or latest version.
2. The anchoring details shown are recommended according to the seismic certification; design Engineer may use alternate anchors within the scope of IBC.
3. Wall anchors in concrete; use a typical concrete anchor as necessary.
4. Expansion anchors as shown. To be installed according to manufacturer's recommendation.
5. The 800-1200A NEMA 3R ATS enclosure may be floor/wall mounted or it may be free standing (floor mounted only); If free standing it must be a minimum of 12" (305mm) away from pipes, conduits or other obstructions to allow for sway during a seismic event.

4. GENERAL DESCRIPTION

Thomson Power Systems TS 870 series of Automatic Transfer Switches employ two mechanically interlocked enclosed contact power switching units and a microprocessor based controller to automatically transfer system load to a generator supply in the event of a utility supply failure. System load is then automatically re-transferred back to the utility supply following restoration of the utility power source to within normal operating limits.

The standard TS 870 series Automatic Transfer Switch is rated for 100% system load and requires upstream over current protection. The TS 870 Automatic Transfer Switch may be supplied with optional integral over current protection within the enclosed contact power switching units for applications such as Service Entrance Rated equipment. Refer to [SECTION 6](#) of this manual for detailed information on current protection.

4.1. TSC 7320 ATS CONTROLLER

The TS 870 series transfer switches use a type TSC 7320 microprocessor based controller, which provides all necessary control functions for fully automatic operation. The controller is equipped with 2.3" back-lit LCD display which provides operating status and controls

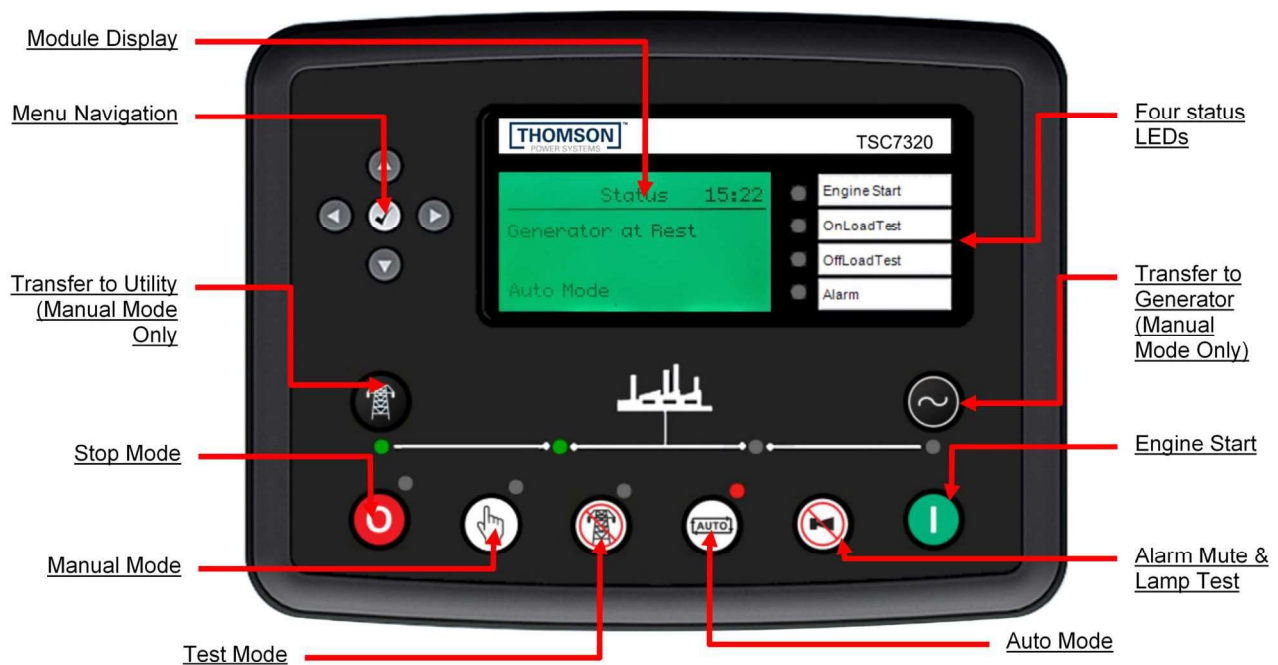

For further information on the TSC 7320 Transfer Controller, refer to separate instruction manual PM180.

4.2. ATS POWER SWITCHING MECHANISM

There are two types of ATS power switching mechanisms provided with TS 870 Series ATS based on amperage size and optional features supplied with the ATS as described below.

4.2.1. “S”- STYLE ATS MECHANISM (100A-800A, OPEN TRANSITION)

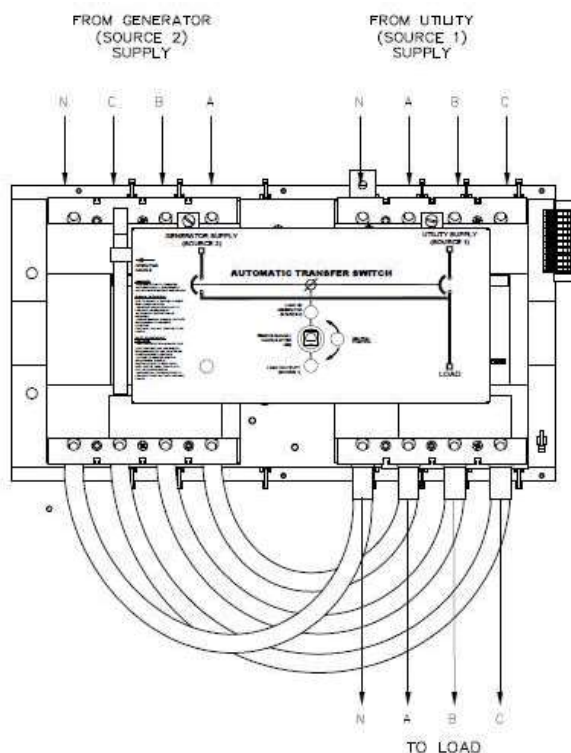

The ATS mechanism consists of 2 power switching devices which are mounted in a horizontal (i.e. side-by-side) configuration. The ATS mechanism provides a positive mechanical interlock to prevent both power switching units from being closed at the same time. The ATS mechanism utilizes a single 120VAC reversible gear motor drive which is mounted in between the two power switching devices. The transfer switch gear motor utilizes the power from the source to which the electrical load is being transferred. The gear motor drives a common drive hub assembly which in-turn operates the power switching device toggles via independent operating arms. Power Switching Device auxiliary contacts are utilized to disconnect control power to the gear motor once correct operating positions are reached.

On 100-250A transfer mechanisms, the load-side of the power switching devices are interconnected via power cable. On 400-800A transfer mechanisms, the load-side of the power switching devices are interconnected via bus bars. The TSC 7320 transfer controller provides a standard neutral position delay timer to allow adequate voltage decay during transfer operation to prevent out of phase transfers.

4.2.2. MO- STYLE ATS MECHANISM (1000A-1200A OPEN & CLOSED TRANSITION)

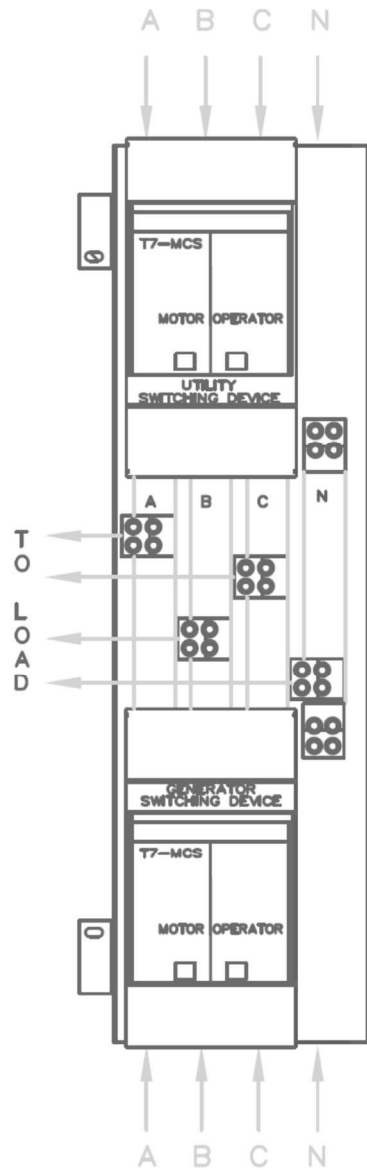

The ATS mechanism consists of 2 power switching devices which are mounted in a vertical stacked configuration. Each power switching device uses a 120VAC motor operator with individual spring charging mechanism and shunt trip/close coils. The transfer switch mechanism utilizes the power from the source to which the electrical load is being transferred to. Open Transition type transfer switches are equipped with a cable interlock mechanism to prevent both power switching devices being closed at the same time.

Closed Transition type transfer switches allow a make-before-break transfer sequence when both sources of power are available. For Closed Transition operation, the TSC 7320 transfer controller provides in-phase closing protection to ensure all transfers are in synchronism prior to closing.

4.3. PRODUCT MODEL CODE

The type of TS 870 series transfer switch supplied is identified by way of a 21 digit product code which appears on the equipment rating plate, or model, on the door of the transfer switch, and on the transfer switch drawings. The model code structure and definitions are as follows:

1	2	3	4	5	6	7	8	9	10	11	12	13	14	15	16	17	18	19	20	21
T	S		8	7																

1-3. SERIES
TS - TRANSFER SWITCH

4 & 5. MODEL
87 - 870 SWITCH

6. POLES
2 - 2 POLE
3 - 3 POLE
4 - 4 POLE

7. CONFIGURATION TYPE
A - ATS
E - DOUBLE BYPASS - 4 BRKR⁹
X - SPECIAL

8 - 11. AMPERAGE
0100
0150
0200⁸
0250
0400
0800
0800
1000
1200

12. APPLICATION
A - STANDARD
B - SERVICE ENTRANCE
C - DUAL UTILITY CONTROL
D - DUAL STANDBY GEN (Slave ATS)
H - DUAL PRIME GEN CONTROL
X - SPECIAL

13. OPERATION TYPE
1 - OPEN TRANSITION
2 - MANUAL ELEC. OP.
3 - CLOSED TRANSITION (MOMENTARY)⁷
X - SPECIAL

14. SAFETY STANDARDS
A - UL 1008 (Service Entrance)
B - CSA C22.2 NO 178
C - UL 1008 / CSA 178
X - NOT APPLICABLE

15. VOLTAGE
1Ø 3 WIRE
D - 120/240

3Ø 4 WIRE (GROUNDED NEUTRAL)
E - 120/208¹
F - 127/220
G - 120/240¹ (DELTA)
H - 220/380²
S - 230/400²
J - 240/416
K - 254/440
M - 277/480¹
N - 347/600¹
Y - MULTI-VOLTAGE (STOCK SWITCHES ONLY)¹
Customer Configurable

16. CONTROLLER
5 - TSC 800 c/w GHC Graphic Display
6 - TSC 7320 c/w LCD DISPLAY
7 - NONE (MANUAL)

3Ø 3 WIRE
P - 208
Q - 220
R - 240
U - 416
V - 480
W - 600
X - SPECIAL

17. ENCLOSURE TYPE
A - NEMA1, ASA #61 GRAY
B - NEMA2, ASA #61 GRAY
C - NEMA12, ASA #61 GRAY
D - NEMA3R SD, ASA #61 GRAY
E - NEMA3R DD, ASA #61 GRAY
F - NEMA3RX4X DD
(304 STAINLESS STEEL)³
G - NONE (OPEN STYLE)
L - NEMA3RX4X DD
(316 STAINLESS STEEL)³
X - SPECIAL

18. UTILITY SWITCHING DEVICE
D - MOLDED CASE SWITCH DRAWOUT⁹
(400 - 1200A)
E - MOLDED CASE SWITCH DRAWOUT⁹
C/W ELECTRONIC TRIP (400-1200A)
F - MOLDED CASE SWITCH DRAWOUT⁹
C/W ELECTRONIC TRIP & GF (400-1200A)
K - MOLDED CASE SWITCH (100 - 1200A)
M - MOLDED CASE SWITCH C/W THER-MAG
TRIP (100-200A)
N - MOLDED CASE SWITCH C/W ELECTRONIC
TRIP (250-1200A)
P - MOLDED CASE SWITCH C/W ELECTRONIC
& GF TRIP (250-1200A)

19. GENERATOR SWITCHING DEVICE
D - MOLDED CASE SWITCH DRAWOUT⁹
(400 - 1200A)
E - MOLDED CASE SWITCH DRAWOUT⁹
C/W ELECTRONIC TRIP (400-1200A)
F - MOLDED CASE SWITCH DRAWOUT⁹
C/W ELECTRONIC TRIP & GF (400-1200A)
K - MOLDED CASE SWITCH (100 - 1200A)
M - MOLDED CASE SWITCH C/W THER-MAG
TRIP (100-200A)
N - MOLDED CASE SWITCH C/W ELECTRONIC
TRIP (250-1200A)
P - MOLDED CASE SWITCH C/W ELECTRONIC
& GF TRIP (250-1200A)

20. POWER CONNECTIONS
A - STANDARD
B - ATS CONNECTION PLATE 100A-400A
C - ATS CONNECTION PLATE 600A-800A
D - ATS CONNECTION PLATE 1000A-1200A
E - ATS CONNECTION PLATE 100A-400A FOR U&G
F - ATS CONNECTION PLATE 600A-800A FOR U&G
G - ATS CONNECTION PLATE 1000A-1200A FOR U&G
X - SPECIAL

21. ATS CONNECTION CONFIGURATION
A - STANDARD
B - ALTERNATE B (400-1200A)
C - ALTERNATE C (400-1200A)
D - ALTERNATE D (400-1200A)

NOTES
¹ MULTI-VOLTAGE CAPABLE
² FOR 50 Hz APPLICATION
³ STANDARD ENCLOSURE RATING IS N3RX
AT 800A, N4X FOR 1000/1200A
AND 600A AND BELOW
⁵ 240V MAX
⁷ CLOSED TRANSITION OPTION 400A - 1200A ONLY
⁹ DOUBLE BYPASS OPTION 400A - 1200A ONLY

4.4. TYPICAL COMMISSIONING PROCEDURES

CAUTION

Commissioning procedures must be performed by qualified personnel only. Ensure the Automatic Transfer Switch (ATS) ATS Power Chassis & Voltage Sensing Isolation Plugs PL12 & PL 15 are disconnected prior to energizing the supply sources. Manually place the transfer switch mechanism in the neutral position prior to applying power. Failure to do so may result in equipment failure or personal injury.

NOTE: The Typical Automatic Transfer Switch Commissioning Procedures Model Series TS 870, Appendix A, is provided for general information only pertaining to typical site installations and applications. Contact Thomson Power Systems for further information as may be required.

5. AUTOMATIC SEQUENCE OF OPERATION

5.1. STANDARD ATS - OPEN TRANSITION

When utility supply voltage drops below a preset nominal value (adjustable from 50% to 95% of nominal) on any phase, an engine start delay circuit is initiated and the transfer to utility supply signal will be removed (i.e. contact opening). Following expiry of the engine start delay period (adjustable from 0 to 30 sec.) an engine start signal (contact closure) will be given.

Once the engine starts, an engine warm-up timer will be initiated. Once the warm-up timer expires (adjustable from 0 to 60 min.), the Transfer to Generator Supply signal (contact closure) will be given to the transfer switch mechanism. The load will then transfer from the utility supply to the generator supply via the motor driven mechanism.

The generator will continue to supply the load until the utility supply has returned. The retransfer sequence is completed as follows: when the utility supply voltage is restored to above 90% of nominal voltage on all phases, a transfer return delay circuit will be initiated. Following expiry of the Utility Return Timer (adjustable from 0 to 60 min), the Transfer to Generator Supply signal will be removed (contact opening), then the Transfer to Utility Supply signal (contact closure) will be given to the transfer switch mechanism. The ATS will then retransfer the load from the generator supply back to the utility supply.

NOTE: A neutral delay timer circuit will delay the transfer sequence in the neutral position (i.e. both power switching devices open) until the neutral delay time period expires.

An engine cooldown timer circuit will be initiated once the load is transferred from the generator supply. Following expiry of the cooldown delay period (adjustable from 0 to

60 minutes), the engine start signal will be removed (contact opening) to initiate stopping of the generator set.

5.2. STANDARD ATS - CLOSED TRANSITION

NOTE: This section applies only to Closed Transition configured transfer switches.

For transfer switches equipped with the Closed Transition transfer option, the ATS is configured to operate as follows:

Under normal closed transition operating conditions, the transfer switch operates automatically during a failure and restoration of utility power and does not require operator intervention.

When utility supply voltage drops below a preset nominal value (50 – 95% of rated adjustable) on any phase, an engine start delay circuit will be initiated and the transfer to utility supply signal will be removed (i.e. contact opening). Following expiry of the engine start delay period (0 - 30 sec. adjustable) an engine start signal (contact closure) will be given.

Once the engine starts, a warmup time delay will be initiated. Once the warmup timer (0-60 Min adjustable) expires, the transfer to generator supply signal (contact closure) will be given to the transfer switch mechanism. The load will then transfer from the utility supply (i.e. opening the utility power switching device) to the generator supply (closing the generator power switching device) via motor driven mechanism to complete a “Break-before-make” open transition transfer sequence.

The generator will continue to supply the load until the utility supply has returned and the retransfer sequence is completed as follows: When the utility supply voltage is restored to above 90% of nominal voltage on all phases, a re-transfer sequence will be initiated once the Utility Return timer expires. The utility will close its power switching device when it is in synchronism with the generator supply utilizing the TSC 7320 in-phase detector. The generator power switching device will immediately trip open approximately 50-100 milliseconds after the utility power switching device closes to complete the make-before-break re-transfer sequence.

An engine cooldown timer circuit will be initiated once the load is transferred from the generator supply. Following expiry of the cooldown delay period (0 - 60 min. adjustable) the engine start signal will be removed (contact opening) to initiate stopping of the generator set.

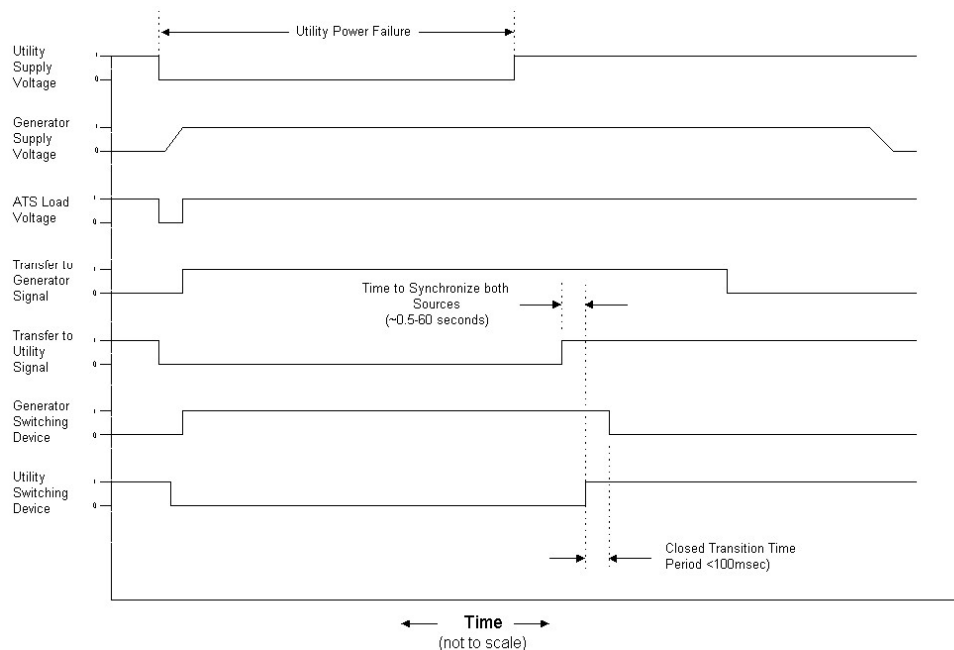

Closed Transition Operation Sequence Diagram

(Normal Power Failure & Return Sequence)

The following operating sequences and time delays are associated with closed transition type transfer switches which momentarily parallel two sources of supply for less than 100 milliseconds.

NOTE: TS870 400A to 1200A, extended parallel and soft load closed transition ATS are implemented using the TSC900 controller. Refer to the TS870 commercial & Industrial ATS brochure PM174 for details.

For closed transition type transfer switches, which utilize extended parallel operation for soft-loading operating sequences, refer to the TSC900 separate instruction manual.

1. Transfer Control Switch (Open/Closed Transition): A two position selector switch is provided on the front of the transfer switch for operator selection of desired operation. The 2 positions are as follows:
 - OPEN TRANSITION: The transfer switch will operate in a “break-before-make” open transition sequence during load transfers. A programmed neutral delay period will occur during the transfer sequence to ensure voltage decays on the load bus before load is re-applied. The two sources will not be paralleled at any time during operation in this mode.

- **CLOSED TRANSITION:** When both sources of supply are available, the transfer switch will operate in a “make-before-break” closed transition sequence during load transfers.

NOTE: If only one source of supply is available during an initiated transfer sequence, the control system will automatically revert to an open transition transfer sequence.

2. **Synchronizing Protection:** To ensure both sources are in synchronism prior to initiating a closed transition transfer sequence, a TSC 7320 in-phase monitor is used. The controller has a Sync page to allow monitoring of phase and voltage of the 2 sources. The built-in sync check relay will block a closed transition transfer sequence until both sources phase angle and voltages are within programmed limits. The synch check relay settings are factory programmed to the following:

Factory Settings:

Frequency Delta:	±0.5Hz
Voltage Delta:	30V PhN
Phase Angle Delta:	10°

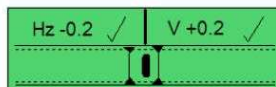
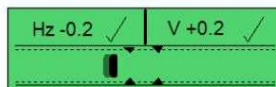
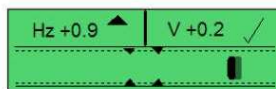

NOTE: The standard closed transition transfer switch does not contain an automatic synchronizer to control the generators frequency or voltage to bring it within limits of the sync check relay. For correct closed transition transfer operation, the system requires the generators frequency to be set within 0.25% of nominal frequency and the generators voltage to be set within 0.5% of nominal voltage.

3. **Closed Transition Time Period:** The time period in which both sources of supply are paralleled together during the closed transition transfer sequence is 50-100 milliseconds (maximum). The time period is inherently controlled by operation of auxiliary contacts from the power switching devices (i.e. when one switching

devices closes, its aux contact closes to initiate tripping of the opposite switching device).

4. Closed Transition Failure Mode Operation: The TSC 7320 continually monitors the closed transition operation time period. The TSC 7320 is factory set for 100 milliseconds that allows normal closed transition operation (i.e. both power switching devices remain closed for less than 100 milliseconds). The alarm circuit is not activated under normal operation. Should the closed transition operation time exceed 100 milliseconds (i.e. both power switching devices remain closed for longer than the normal closed transition time period plus the setting of TSC 7320 timer, the following sequence of events will occur:

- TSC 7320 time delay period will expire and will activate auxiliary trip relay.
- If the transfer switch was transferring power from the generator source to the utility source and the generator switching device failed to open, an auxiliary trip relay will trip open the utility power switching device to immediately separate the two power sources. If the transfer switch was transferring power from the utility source to the generator source and the utility switching device failed to open, an auxiliary trip relay will trip open the generator power switching device to immediately separate the two power sources.

NOTE: The maximum time period both sources will remain paralleled under this failure mode is 200 milliseconds.

- The original source (i.e. prior to the transfer sequence) will remain on load, separated from the other source. TSC 7320 controller will indicate a failure condition which must be manually reset before the transfer switch will re-attempt subsequent transfers. For further information on the TSC 7320 features and operation, refer to the separate product instruction manual.

NOTE: Should the TSC7320 fail to separate the 2 sources under 350msec, a secondary paralleling timer relay will issue a trip signal to both power switching devices. The maximum time period both sources will remain paralleled under this failure mode is 500 milliseconds.

Two alarm contacts are provided for the Closed Transition Failure Mode (i.e. one for a failed generator power switching device and one for the utility power switching device. The contacts are for customer use to remotely trip open upstream devices should an abnormal condition persist.

5. Transfer Fail Alarm (Switching Device Fail to Close): The TSC 7320 provides a timer detect and alarm abnormal operating conditions. Should a power switching device fail to close for any reason within a 5-minute time period, an alarm light and alarm relay contact will be activated. For further information on the TSC 7320 features and operation, refer to the separate product instruction manual.

5.3. SERVICE ENTRANCE RATED ATS

NOTE: This section applies only to Service Entrance configured transfer switches.

5.3.1. NORMAL OPERATION

Under normal conditions, the load is energized from the utility supply through the closed utility transfer power switching device. If the utility power fails, the generator will start and the load will be re-energized via the closed generator transfer power switching device. In the normal operating mode, the Service Disconnect switch shall be in the energized position.

5.3.2. OVER CURRENT TRIP

Should the utility power switching device trip open due to an over current condition, TSC 7320 transfer controller will initiate an engine start signal and will permit transfer of the load to the generator supply. The utility source will be locked out and the load will remain on the generator supply until the TSC 7320 alarm signal is manually reset.

Should the generator power switching device trip open due to an over current condition, TSC 7320 transfer controller will initiate transfer of the load to the utility supply. The generator source will be locked out and the load will remain on the utility supply until the TSC 7320 alarm signal is manually reset.

5.3.3. SERVICE DISCONNECT PROCEDURE

To perform a service, disconnect (i.e. to disconnect the utility and generator supplies), the following procedure is required:

1. Move the Service Disconnect control switch located on the door of the transfer switch to the Transfer to Neutral position and wait 2 seconds for the ATS to complete a transfer to the neutral position.
2. Once the ATS has transferred to the neutral position, move the Service Disconnect control switch to the Disconnected position.
3. Verify that the Service Disconnected pilot light is illuminated. If the Light is illuminated, the service has been successfully disconnected and it is safe to perform any maintenance procedures as required. In this condition, the transfer switch is in the neutral position, with both utility and generator transfer power switching devices open. The transfer switch will remain in this condition, regardless of condition of the utility and generator supplies.

NOTE: If the Service Disconnect Light is not illuminated, additional procedures are required (**refer to the following procedure #5.3.4**).

4. Attach safety lockout padlock to the "Service Disconnect" control switch to prevent unauthorized change in operating condition and verify transfer

switch door is locked closed. If the door is not locked, turn and remove door key.

WARNING

Close and lock the transfer switch enclosure door before connecting power sources.

5. To re-energize the load, remove the padlock(s) from the service disconnect control switch, and move the switch to the Energized position. The transfer switch will immediately return to the utility, and the controller will remain in STOP mode. When required, put the controller back in Auto mode.

5.3.4. ADDITIONAL SERVICE DISCONNECT PROCEDURES (S-STYLE 100A-800A OPEN TRANSITION MECHANISM)

If the Service Disconnected pilot light is not illuminated, the service will not have been successfully disconnected and therefore it is not safe to perform any maintenance until the following additional procedures are performed:

DANGER

Arc Flash and Shock Hazard. Will cause severe injury or death. Do not open equipment until ALL power sources are disconnected.

This equipment must be installed and serviced only by qualified electrical personnel utilizing safe work practices and appropriate Personal Protective Equipment (PPE). Failure to do so may cause personal injury or death.

1. Open the door to the transfer switch using a suitable tool and opening the door lock with the key.
2. Visually inspect the actual position of the transfer switch mechanism. If the position of the transfer switch mechanism is clearly in the neutral position and the load bus is de-energized on all phases, the service has been successfully disconnected. Proceed to Step. 4.

If the position of the transfer switch mechanism is not in the neutral position or the load bus is energized, further procedures are required.

NOTE: If the position of the transfer switch mechanism is clearly in the Neutral position, the Service Disconnected pilot light may not have illuminated due to the following reasons:

a) Utility and generator supply voltages are not present, and there is no 24VDC auxiliary power. The pilot light needs power either from the AC sources, or from 24VDC auxiliary power.

b) The pilot light may be burnt out. The bulb should be immediately replaced with a 24VDC rated LED bulb.

a. Failure of one or more of the sensing/logic contacts. A qualified service technician is required to trouble shoot this specific condition. Switch the utility control circuit isolation switch to the de-energized position to remove utility control power. To isolate the AC voltage sensing and control circuits, remove the isolation plugs PL12 and PL15.

NOTE: The AC power conductors will still remain energized. Once all the control and voltage sensing circuits are de-energized and isolated the Service Disconnected pilot light will not illuminate due to loss of control power.

NOTE: To return the transfer switch back to normal operation, the utility control circuit disconnect switch and ATS Power Chassis & Voltage Sensing Isolation Plugs (PL12 & PL 15) must be switched on and reconnected for correct operation.

3. If the position of the transfer switch mechanism is not in the Neutral position, manually operate the transfer switch mechanism as follows:

NOTE: Refer to product drawings in [Sections 10 & 11](#) for identification of Transfer Switch Mechanism style supplied with the Transfer Switch.

- **S-Style Mechanism:** Insert the operating handle into the front of the transfer mechanism and turn the operating handle until the position indication on the mechanism clearly shows the Neutral position.

WARNING

Failure to move the mechanism to the Neutral Position may result in serious personal injury or death due to electrical shock.

4. Close the transfer switch door securely using a suitable tool. Lock the door in the closed position and remove the key.

WARNING

Failure to positively lock closed and secure the transfer switch door may result in serious personal injury or death due to electrical shock.

5. Attach a safety lockout padlock to the service disconnect control switch to prevent unauthorized change in operating condition and verify transfer switch door is locked closed.
6. To re-energize the load, remove the padlock(s) from the service disconnect control switch, and move the switch to the Energized position. The transfer switch will immediately return to the utility, and the controller will remain in STOP mode. When required, put the controller back in Auto mode.

5.3.5. ADDITIONAL SERVICE DISCONNECT PROCEDURES (MO STYLE ATS MECHANISM)

If the Service Disconnected pilot light is not illuminated, the service will not have been successfully disconnected and therefore it is not safe to perform any maintenance until the following additional procedures are performed:

DANGER

Arc Flash and Shock Hazard. Will cause severe injury or death. Do not open equipment until ALL power sources are disconnected.

This equipment must be installed and serviced only by qualified electrical personnel utilizing safe work practices and appropriate Personal Protective Equipment (PPE). Failure to do so may cause personal injury or death.

1. Visually inspect the actual position of the transfer switch power switching devices. If both power switching devices indicate they are open, the transfer switch is clearly in the Neutral position, the service has been successfully disconnected. Proceed to Step. 4.

If either power switching device is not in the Open position, or the load bus is energized, further procedures are required.

NOTE: If the power switching devices are both Open, the Service Disconnected pilot light may not have illuminated due to the following reasons:

- a) Utility and generator supply voltages are not present (the TSC 7320 requires AC supply voltage to be present to power the pilot light).
- b) The pilot light may be burnt out. The bulb should be immediately replaced with a 24VDC rated LED bulb.

b. Failure of one or more of the sensing/logic contacts. A qualified service technician is required to trouble shoot this specific condition. Switch the utility control circuit isolation switch to the de-energized position to remove utility control power. To isolate the ATS Power Chassis & Voltage Sensing circuits, remove the isolation plugs PL12 and PL15.

NOTE: The AC power conductors will still remain energized. Once all the control and voltage sensing circuits are de-energized and isolated the Service Disconnected pilot light will not illuminate due to loss of control power.

NOTE: To return the transfer switch back to normal operation, the utility control circuit disconnect switch and ATS Power Chassis & Voltage Sensing Isolation Plugs (PL12 & PL 15) must be switched on and reconnected for correct operation.

2. If the position of both power switching units are not in the Open position, the power switching units must be manually operated as follows. To operate manually, push the power switching units Open pushbutton. The unit should then open. Repeat for the other power switching unit.
3. Close all transfer switch doors securely using a suitable tool. Lock the door in the closed position and remove the key.

WARNING

Failure to move the mechanism to the Neutral Position may result in serious personal injury or death due to electrical shock.

4. Attach a safety lockout padlock to the service disconnect control switch to prevent unauthorized change in operating condition and verify transfer switch door is locked closed.
5. To re-energize the load, remove the padlock(s) from the service disconnect control switch, and move the switch to the Energized position. The transfer switch will immediately return to the utility, and the controller will remain in STOP mode. When required, put the controller back in Auto mode.

5.4. TEST MODES

The transfer switch may be tested utilizing the TSC 7320 front panel buttons or remote power fail test input. A simulated utility power failure condition will be activated when the test mode is selected. The transfer switch will operate as per a normal utility power fail condition.

The transfer switch will remain on generator supply until the test mode is terminated. It will then immediately transfer back to the utility supply and then continue to operate the generator set for its cooldown period then stop.

NOTE: The transfer switch will automatically return to the utility supply (if within nominal limits) if the generator set fails while in the test mode.

5.4.1. ON LOAD TEST

To initiate an ATS On Load Test, press the test button on the TSC 7320 controller to enter test mode.

Next, press the gen start button (green), and the controller will start the generator and once it reaches the nominal voltage and frequency, the switch will be transferred to the generator and take over the load.

To stop the on-load test and return to normal, press the auto button, and the controller will start a utility return delay timer, and transfer back to the utility when the timer expires. The generator will continue to run until the cooling expires, and then it will turn off the generator.



Note :

Pushing the red stop button will initiate a return to Utility request followed by an engine stop. If the utility is available, the ATS will transfer to utility and stop the engine ignoring any countdown timers. If the Utility is not available, the controller will turn off the generator, and generate a *Mains Fail to Close Alarm*.

5.4.2. OFF LOAD TEST

To initiate an ATS off load test, press the manual button on the TSC 7320 controller to enter manual mode.

Next, press the gen start button (green), and the controller will start the generator, but the switch will NOT transfer to generator, even if the source is healthy.

To stop the off-load test and return to normal, press the STOP button, and the controller will turn off the generator. If the Auto mode button is pushed, the controller will start a countdown timer and then turn off the generator.



6. OVER CURRENT PROTECTION

Thomson Power Systems **TS 870** series of Automatic Transfer Switches may be supplied with or without integral over current protection as described below:

6.1. STANDARD TS 870 AUTOMATIC TRANSFER SWITCH

The standard TS 870 Automatic Transfer Switch does not contain any integral over current protection and requires upstream over current protection devices for both Utility and Generator sources. The Standard TS 870 can withstand a maximum short circuit fault current as noted in [SECTION 13](#) of this manual. The standard TS 870 transfer switch model without integral over current protection is identified in the product model code. Refer to [SECTION 4.3](#) of this manual for further details on model coding.

6.2. OPTIONAL TS 870 AUTOMATIC TRANSFER SWITCH WITH INTEGRAL OVER CURRENT PROTECTION

TS 870 transfer switches will have integral over current protection supplied on the Utility source as standard. The type of over current protection utilized is dependent upon ATS amperage size and optional features specified. For transfer switches rated 100A through 200A, over current protection is non-adjustable thermal-magnetic type trip units. For transfer switches rated 250A through 1200A over current protection is adjustable electronic type with long time & instantaneous trip unit elements with optional ground fault protection elements.

NOTE: Ground fault protection is supplied as standard on 1000A and 1200A transfer switches that are used on systems greater than 240V.

An upstream over current protection device is required on the generator source which feeds the TS 870 Transfer Switch if integral over current protection option is not specified on the ATS.

NOTE: For models of transfer switch with adjustable integral over current protection trip units, the over current protection must be set prior to operation. The equipment will be shipped from the factory with a long-time current setting of 100% (of the equipment rating) and maximum instantaneous/short-time current and time delay settings.

WARNING

Do Not Energize this equipment until device settings have been verified to ensure proper system protection & coordination. Failure to do so may result in equipment failure.

Refer to [SECTION 4.3](#) Product Model Code for types of integral over current protection which are supplied with the transfer switch.

7. GENERAL NOTES ON SERVICING TRANSFER SWITCH MECHANISMS

DANGER

Arc Flash and Shock Hazard. Will cause severe injury or death. Do not open equipment until ALL power sources are disconnected. This equipment must be installed and serviced only by qualified electrical personnel utilizing safe work practices and appropriate Personal Protective Equipment (PPE). Failure to do so may cause personal injury or death.

NOTE: Refer to [SECTION 4.2](#) of this manual for identification of Transfer Switch Mechanism styles supplied for the Transfer Switch.

When performing any service work on the transfer mechanism, it is imperative that the following be observed:

- 7.1. To maintain mechanical integrity, ensure that:
 - Ensure that power switching device travel far enough to reset any internal trip unit (it is more important for the toggle to go fully in the Off direction, than in the On direction).
 - Mechanical interlocking is correct when one power switching opens well before the other should close.
 - All fasteners are adequately tightened.
 - The operating linkages are not damaged or bent, and that all bearing points operate freely.
 - On S Style transfer switch mechanisms, check nylon lock nuts on bolt pivot points. Operation arms should move freely without excessive play.
- 7.2. To maintain electrical integrity, ensure that:
 - All electrical connections, especially power connections, are clean and adequately tightened. Corroded or loose power connections will cause destructive heating, and may cause premature tripping.
 - All insulating devices are in place and in good condition.
 - No moisture or other contamination is present.
 - Electrical conductors are adequately secured away from moving parts.
- 7.3. To maintain operational integrity, ensure that:

- All control devices are in good condition and correctly calibrated.
- All control devices including TSC 7320 connectors are adequately secured in their plug-in fixtures.

Only qualified personnel should undertake Service work. Failure to correctly maintain an automatic transfer switch may present a hazard to life and equipment. Full operational testing must be done prior to placing a transfer switch in service subsequent to any maintenance or repair. Any service work involving electrical components requires high-potential testing to ensure that required insulation levels have been maintained.

8. ATS MANUAL OPERATING INSTRUCTIONS

DANGER

Arc Flash and Shock Hazard. Will cause severe injury or death. Do not open equipment until ALL power sources are disconnected. This equipment must be operated only by qualified electrical personnel utilizing safe work practices and appropriate Personal Protective Equipment (PPE). Failure to do so may cause personal injury or death.



DANGER

HAZARD OF ELECTRICAL SHOCK, EXPLOSION, OR ARC FLASH

This equipment must be serviced only by qualified electrical personnel utilizing safe work practices and appropriate Personal Protective Equipment (PPE).

Many components of this equipment operate at line voltage.

DO NOT TOUCH. Use only electrically isolated tools.

Install and close all covers before applying power to this equipment

Do not open covers to equipment until ALL power sources are disconnected

Failure to do so may cause personal injury or death

The Transfer Switch can be operated manually using electrically operated push buttons located at the face of the TSC 7320 controller, or using the operating handle in case of “S” style transfer switch or mechanical operated pushbuttons inside the ATS on the front of each power switching device in case of “MO” Style transfer switch.

8.1. TSC 7320 PUSH BUTTON CONTROLS FOR MANUAL OPERATION

AUTO: This selects automatic operation of the transfer switch. The power switching device will automatically open/close as detailed in the sequence of operation per section 5 of this manual.

MAN: This position inhibits automatic operation and automatic engine starting. The power switching device can be manually operated via electrically interlocked “Transfer to Main” and “Transfer to Generator” pushbutton located at the face of the TSC 7320 controller

START: Start the generator at manual mode and ensure it operates at nominal voltage and frequency.

TRANSFER TO MAIN: Transfer power from generator to utility supply in manual mode.

TRANSFER TO GENERATOR: Transfer power from utility to generator supply in manual mode.

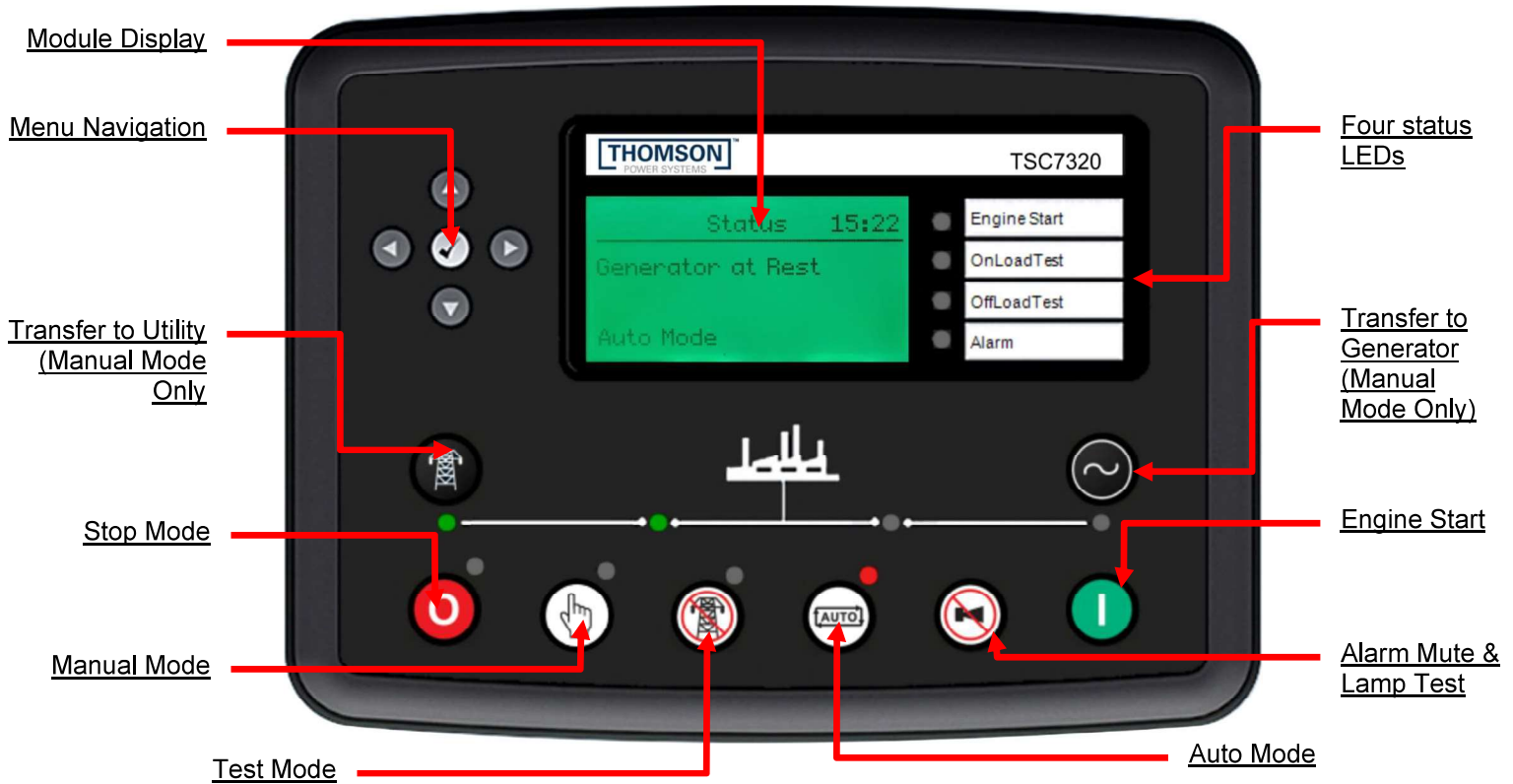

NOTE

When the Manual Mode is selected, the engine start output logic is disabled. Where generator voltage is required during manual operation the local generator controls must be set for manual operation.

8.2. S-STYLE ATS - MANUAL OPERATION

The “S” - Style Transfer Switch can be operated manually using electrically operated push buttons located at the face of the TSC 7320 controller or by disconnecting the controller power isolation plugs, and then using the operating handle after the controller has powered down.

MANUAL TRANSFER TO GENERATOR SUPPLY VIA TSC7320 MANUAL CONTROLS (Open Transition)

To transfer manually to generator supply, follow procedure listed below;

1. Press “Manual Mode” pushbutton located at the face of the TSC 7320 Controller.
2. Press “Start” pushbutton to manually start the generator set and ensure it is operating at normal voltage and frequency, with its output circuit breaker closed.
3. Press “Transfer to Generator” pushbutton to manually transfer the power from utility to generator supply. Verify the utility power switching device contacts are open and generator power switching device contacts are closed via transfer switch status indicator located at the center of the mechanism. It will be marked as “G” at this position.

MANUAL TRANSFER TO UTILITY SUPPLY VIA TSC 7320 MANUAL CONTROLS (Open Transition)

To transfer manually to utility supply, follow procedure listed below;

1. Press “Manual Mode” pushbutton located at the face of the TSC 7320 Controller.
2. Press “Transfer to Utility” pushbutton to manually transfer the power from generator to utility supply. Verify the generator power switching device contacts are open and utility power switching device contacts are closed via transfer switch status indicator located at the center of the mechanism. It will be marked as “U” at this position.

MANUAL TRANSFER BETWEEN GENERATOR AND UTILITY SUPPLY USING OPERATING HANDLE (Open Transition)

The transfer switch may be operated manually for maintenance or emergency operation conditions provided both Utility and Generator supplies are de-energized prior to manual operation.

Once both Utility and Generator supplies are de-energized the following procedure can be used to operate the Transfer Switch manually.

1. Disconnect the ATS Power Chassis & Voltage Sensing Isolation Plugs (PL12 & PL15) to prevent automatic operation.
2. Open ATS enclosure door and locate Manual Operation Handle provided with the transfer switch (see photo below)

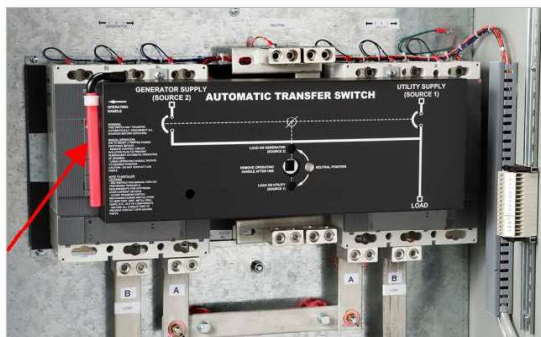

Manual Operation Handle

3. Insert manual handle into the center hole of the transfer switch mechanism.
4. To manually operate mechanism, rotate handle to the desired position as labeled on the ATS mechanism cover. Do not over-torque handle once position has been attained. It can be verified by transfer switch status indicator located at the center of the mechanism. It will be either marked as "U" or "G" depending upon the position of the transfer switch.
5. Once ATS is manually operated to desired position, re-close ATS enclosure door, then re-energize supply sources to re-energize the load.

8.3. MO STYLE ATS -MANUAL OPERATION

The MO-Style Transfer Switch can be operated manually using electrically operated push buttons located at the face of the TSC 7320 controller, or using the mechanical operated pushbuttons inside the ATS on the front of each power switching device.

NOTE: It is not recommended to use the internally mounted pushbuttons unless in an emergency condition should the electrically operated buttons fail to operate the ATS manually.

MANUAL TRANSFER TO GENERATOR SUPPLY VIA TSC7320 MANUAL CONTROLS (Open Transition)

To transfer manually to generator supply, follow procedure listed below;

1. Press “Manual Mode” pushbutton located at the face of the TSC 7320 Controller.
2. Press “Start” pushbutton to manually start the generator set and ensure it is operating at normal voltage and frequency, with its output circuit breaker closed.
3. Ensure the generator power switching device’s spring mechanism is fully charged as indicated by Yellow –Spring Charged flag. If the power switching device is not charged, it maybe manually charged by locating the manual charge handle mechanism on the face of the power switching device, then pulling forward and then down 1-6 times until the Yellow Spring Charged flag is displayed. Refer to Diagrams #1 & 2 below and the power switching device’s manual for further information.

NOTE:

The yellow OK Flag indicates the power switching device is charged however it may not be ready to close if the transfer switch mechanical or electrical interlocks are not satisfied.

4. Press “Transfer to Generator” pushbutton to manually transfer the power from utility to generator supply. Verify the utility power switching device contacts are open via Green (O) Open contact status flag. Also verify generator power switching device contacts are closed via Red (I) Closed contact status flag

MANUAL TRANSFER TO UTILITY SUPPLY VIA TSC 7320 MANUAL CONTROLS (Open Transition)

To transfer manually to utility supply, follow procedure listed below;

1. Press “Manual Mode” pushbutton located at the face of the TSC 7320 Controller.
2. Ensure the utility power switching device’s spring mechanism is fully charged as indicated by Yellow –Spring Charged flag. If the power switching device is not charged, it maybe manually charged by locating the manual charge handle mechanism on the face of the power switching device, then pulling forward and then down 1-6 times until the Yellow Spring Charged flag is displayed. Refer to Diagrams #1 & 2 below and the power switching device’s manual for further information.

NOTE:

The yellow OK Flag indicates the power switching device is charged however it may not be ready to close if the transfer switch mechanical or electrical interlocks are not satisfied.

3. Press “Transfer to Utility” pushbutton to manually transfer the power from generator to utility supply. Verify the generator power switching device contacts are open via Green (O) Open contact status flag. Also verify utility power switching device contacts are closed via Red (I) Closed contact status flag.

MANUAL TRANSFER TO GENERATOR SUPPLY VIA MECHANICALLY OPERATED POWER SWITCHING DEVICES PUSH BUTTONS (Open Transition)

To transfer manually to generator supply, follow procedure listed below;

1. Disconnect the ATS Power Chassis & Voltage Sensing Isolation Plugs (PL12 & PL15) to prevent automatic operation.
2. Ensure the generator power switching device's spring mechanism is fully charged as indicated by Yellow –Spring Charged flag. If the power switching device is not charged, it maybe manually charged by locating the manual charge handle mechanism on the face of the power switching device, then pulling forward and then down 1-6 times until the Yellow Spring Charged flag is displayed. Refer to Diagrams #1 & 2 below and the power switching device's manual for further information.

NOTE:

The yellow OK Flag indicates the power switching device is charged however it may not be ready to close if the transfer switch mechanical or electrical interlocks are not satisfied.

3. Manually open the utility power switching device using the red (O) Mechanical Open pushbutton located on the face of the power switching device. Refer to Diagrams #1 & 2 below. Verify the utility power switching device contacts are open via Green (O) open contact status flag.
4. Manually Close the generator power switching device using the red (I) Mechanical Close pushbutton located on the face of the power switching device. Refer to Diagrams #1 & #2 below. Verify the generator power switching device contacts are closed via red (I) closed contact status flag.

MANUAL TRANSFER TO UTILITY SUPPLY VIA MECHANICALLY OPERATED POWER SWITCHING DEVICES PUSH BUTTONS (Open Transition)

To transfer manually to the utility supply, follow procedure listed below;

1. Disconnect the ATS Power Chassis & Voltage Sensing Isolation Plugs (PL12 & PL15) to prevent automatic operation.
2. Ensure the utility power switching device's spring mechanism is fully charged as indicated by Yellow –Spring Charged flag. If the power switching device is not charged, it maybe manually charged by locating the manual charge handle mechanism on the face of the power switching device, then pulling forward and then down 1-6 times until the Yellow Spring Charged flag is displayed. Refer to Diagrams #1 & 2 below and the power switching device's manual for further information.

NOTE:

The yellow OK Flag indicates the power switching device is charged however it may not be ready to close if the transfer switch mechanical or electrical interlocks are not satisfied.

3. Manually open the generator power switching device using the red (O) Mechanical Open pushbutton located on the face of the power switching device. Refer to Diagrams #1 & 2 below. Verify the utility power switching device contacts are open via Green (O) open contact status flag.
4. Manually Close the utility power switching device using the red (I) Mechanical Close pushbutton located on the face of the power switching device. Refer to Diagrams #1 & #2 below. Verify the generator power switching device contacts are closed via red (I) closed contact status flag.

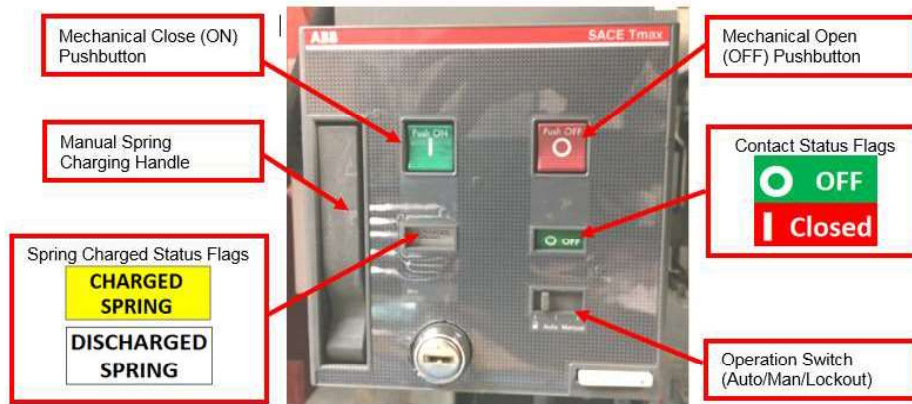

DIAGRAM #1
400A-800A Closed Transition ATS
Power Switching Device

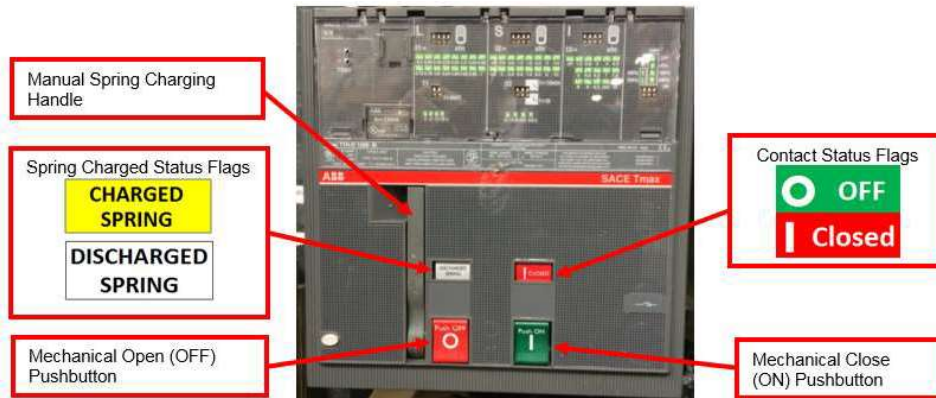

DIAGRAM #2
1000A-1200A Open/Closed Transition ATS
Power Switching Device

9. RECOMMENDED MAINTENANCE

DANGER

Arc Flash and Shock Hazard. Will cause severe injury or death.

Do not open equipment until ALL power sources are disconnected

This equipment must be installed and serviced only by qualified electrical personnel utilizing safe work practices and appropriate Personal Protective Equipment (PPE).

Failure to do so may cause personal injury or death

1. DO NOT perform dielectric tests on the equipment with the control components in the circuit.
2. Check if control components are tight in sockets.
3. Periodically inspect all terminals (load, line and control) for tightness. Re-torque all bolts, nuts and other hardware. Clean or replace any contact surfaces, which are dirty, corroded or pitted.
4. Transfer switches should be in a clean, dry and moderately warm location. If signs of moisture are present, dry and clean transfer switch. If there is corrosion, try to clean it off. If cleaning is unsuitable, replace the corroded parts. Should dust and/or debris gather on the transfer switch, brush, vacuum, or wipe clean. DO NOT blow dirt into power switching devices.
5. Test the transfer switch operation. While the unit is exercising, check for freedom of movement, hidden dirt, corrosion or any excessive wear on the mechanical operating parts. Ensure that the power switching device travel is correct.
6. Verify all program settings on the TSC 7320 controller as per the TSC 7320 component calibration label on the rear cover of the controller.
7. Transfer Mechanism 100A-800A S Style - lubrication of drive hub/operator arm interface. Use high viscosity moly lubricant.
8. The motor and gearbox on all Transfer Mechanism styles are permanently lubricated, and should not require attention under normal operating circumstances.

10. FRONT VIEW (TYPICAL) 3 / 4 POLE 100A-800A S-Style TRANSFER MECHANISM (Mechanism Front Cover Removed)

NOTE 1: 3 PHASE CONNECTION SHOWN. FOR SINGLE PHASE CONNECT TO A & C ONLY

NOTE 2: CONTROL CIRCUIT ISOLATION PLUG IS LOCATED ON INSIDE OF ENCLOSURE DOOR.

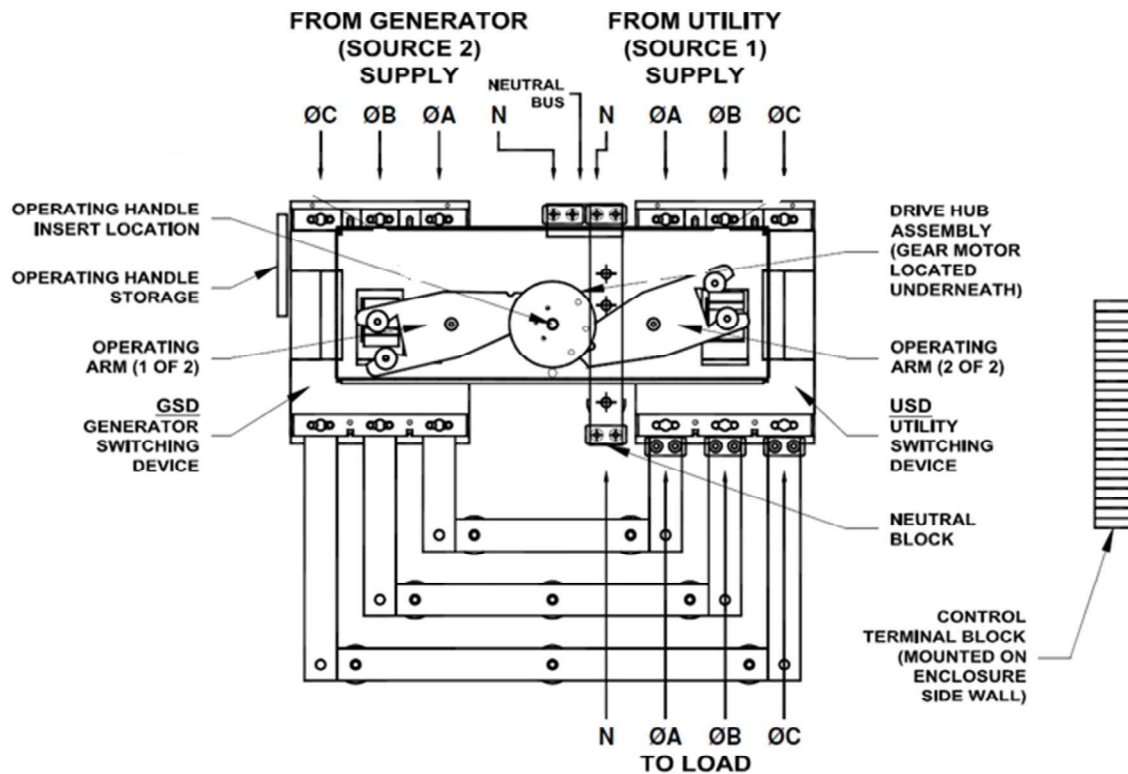

11. FRONT VIEW (TYPICAL) 3 / 4 POLE 1000A-1200A MECHANISM MOTOR OPERATOR (MO) STYLE TRANSFER MECHANISM

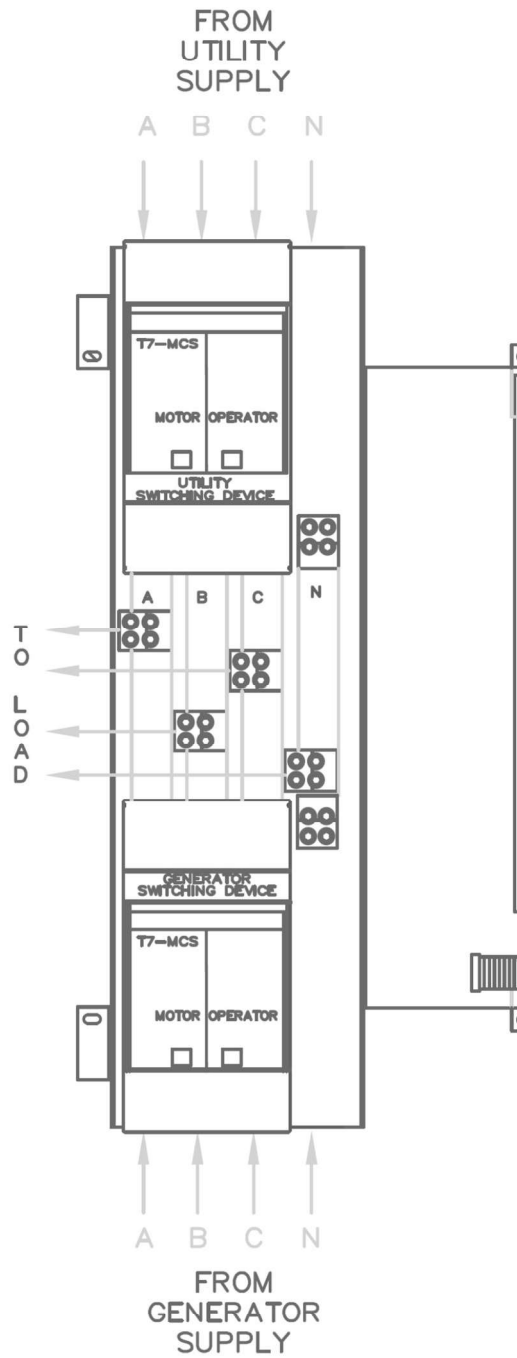

12. CABLE TERMINAL INFORMATION

BASIC MODEL	TERMINAL RATING		CONNECTION TIGHTNESS (In-lbs.)	
	QTY PER PHASE	RANGE	TERMINAL MOUNTING SCREW	CABLE CLAMP
TS 87xA-0100	1	#14-1/0	120	50
TS 87xA-0150	1	#2-4/0	120	120
TS 87xA-0200	1	#6-350MCM	150	275
TS 87xA-0250	1	#6-350MCM	150	275
TS 87xA-0400 ¹	2	2/0-500MCM	72	275
TS 87xA-0600 ¹	2	2/0-500MCM	72	275
TS 87xA-0800 ¹	3	2/0-500MCM	110	375
TS 87xA-1200 ¹	4	4/0-500MCM	375	375

1. Optional terminal ratings are available in some models – Consult Thomson Power Systems.
2. For other model types not shown, contact Thomson Power Systems for further information.

13. REQUIREMENTS FOR UPSTREAM CIRCUIT PROTECTIVE DEVICES

13.1. WITHSTAND CURRENT RATINGS (ALL MODELS WITHOUT INTEGRAL OVERCURRENT PROTECTION OPTION)

BASIC MODEL	MAX. VOLTAGE	RATED CURRENT (A)	WITHSTAND CURRENT RATING AMPS (RMS) ₁		
			@240V	@480V	@600V
TS87xA-0100	600	100	65,000	25,000	18,000
TS87xA-0150	600	150	65,000	25,000	18,000
TS87xA-0200	240	200	65,000	N/A	N/A
TS87xA-0250 ³	600	250	65,000	65,000	35,000
TS87xA-0400	600	400	65,000	50,000	35,000
TS87xA-0600	600	600	65,000	50,000	35,000
TS87xA-0800	600	800	65,000	50,000	35,000
TS87A-1000/1200	600	1000/1200	150,000	100,000	65,000

1. Standard ratings only are shown. Consult Thomson Power Systems for versions with higher withstand current ratings.
2. For other model types not shown, contact Thomson Power Systems for further information.
3. With stand rating specified is for 250A, 3P. For 250A, 4P, the withstand rating are 65KA@240V, 35KA@480V and 22KA@600V

13.2. INTERRUPTING CAPACITY CURRENT RATINGS (ALL MODELS WITH INTEGRAL OVERCURRENT PROTECTION OPTION)

BASIC MODEL	MAX. VOLTAGE	RATED CURRENT (A)	INTERRUPTING CAPACITY CURRENT RATING AMPS (RMS) 1		
			No Upstream Overcurrent Protection Required		
			@240V	@480V	@600V
TS87xA-0100	600	100	65,000	25,000	14,000
TS87xA-0150	600	150	65,000	25,000	14,000
TS87xA-0200	240	200	65,000	N/A	N/A
TS87xA-0250 ³	600	250	65,000	65,000	35,000
TS87xA-0400	600	400	65,000	50,000	25,000
TS87xA-0600	600	600	65,000	50,000	25,000
TS87xA-0800	600	800	65,000	50,000	25,000
TS87xA-1000/1200	600	1000 / 1200	150,000	100,000	65,000

1. Standard ratings only are shown. Consult Thomson Power Systems for versions with higher interrupting capacity current ratings.
2. For other model types not shown, contact Thomson Power Systems for further information.
3. With stand rating specified is for 250A, 3P. For 250A, 4P, the withstand rating are 65KA@240V, 35KA@480V and 22KA@600V

14. GROUND FAULT SITE TEST REQUIREMENTS

Per NEC and UL1008, a ground fault protected system shall be performance tested when first installed on site. A written record of this shall be made and be available to the authority having jurisdiction. A form is provided at the back of this manual for this purpose – see **SECTION 20**.

Confirm and record actual trip set points in the form provided which is to be made available on request by inspection authority.

14.1. PERFORMANCE TEST

Qualified Field Service technicians require a calibrated current injection test apparatus and must be knowledgeable in breaker testing to provide primary neutral CT injection up to or greater than the trip set point as selected by the responsible party. As indicated in the NEC, the maximum setting of the ground fault protection shall be 1200 amps, and the maximum time delay shall be 1 second for ground faults equal to or greater than 3000 amps.

The inspection authority should be contacted to confirm actual test requirements as these may vary by region or local code requirements.

The interconnected system shall be evaluated to ensure compliance with the appropriate schematic drawings. The proper location of sensors and power cabling shall be determined. The grounding points of the system shall be verified to determine that ground paths do not exist that would bypass the sensors. The use of high-voltage testers and resistance bridges may be required. A simulated fault current is to be generated by a coil around the sensors. The reaction of the circuit-interrupting device is to be observed for correct response. The results of the test are to be recorded on the test form provided.

15. TROUBLESHOOTING

DANGER

Arc Flash and Shock Hazard. Will cause severe injury or death.

Do not open equipment until ALL power sources are disconnected

This equipment must be installed and serviced only by qualified electrical personnel utilizing safe work practices and appropriate Personal Protective Equipment (PPE). Failure to do so may cause personal injury or death

MALFUNCTIONS	PROBABLE CAUSES	CORRECTIVE ACTIONS
Will not re-transfer to utility source upon restoration	Utility Return Time (mains transient) delay period in TSC 7320 has not yet expired.	Verify TSC 7320 time delay setting
	A Load Test mode has been activated locally or remotely	Check TSC 7320 load test LED status indicators
	An Exercise Test mode has been activated by the TSC 7320 scheduler	Check TSC 7320 status screen for Exercise Test is active
	Utility supply is not operating at correct voltage or frequency levels.	Verify correct nominal levels the utility source should be operating at and compare to TSC 7320 settings for under/over voltage, voltage phase balance and under/over frequency
	TSC 7320 has incorrect utility voltage or frequency settings for the ATS.	Re-Program TSC 7320 with correct settings as required for voltage or frequency.
	Utility Phase Rotation is not matched with Generator supply (first time transfer).	Check Generator & Utility Voltage Phase rotation matches on TSC 7320 Utility & Generator Voltage Pages. If power cabling has non-matching phase rotation, reverse power conductors on one phase on one of the supplies
	TSC 7320 utility voltage sensing connection plug (38,39,40,41) is unplugged	Verify all TSC 7320 connectors are fully inserted
	ATS Power Chassis & Voltage Sensing Isolation Plugs (PL12 or PL15) are unplugged	Verify both PL12 & PL15 connectors are fully inserted
	TSC 7320 has "Transfer Fail" alarm activated.	Determine cause of alarm and rectify before resting the alarm on TSC 7320
	Defective Utility power switching unit close coil (MO Style ATS Mechanism only)	Verify Utility power switching device close coil is fully functional.
	Defective generator power switching unit trip coil (open transition) (MO Style ATS Mechanism only)	Verify Gen power switching device trip coil is fully functional. The generator power switching unit must be open before the utility power switching device is permitted to close (open transition).
	Defective ATS mechanism motor (S - Style ATS Mechanism only)	Verify motor does not rotate when 120VAC is applied directly to motor leads. If defective Return to Thomson Power systems using RMA process
A loose control wire connection	Check all wiring connections in the ATS	

Will not re-transfer to utility source upon restoration (cont'd)	Defective TSC 7320 controller	Verify TSC 7320 has 24VDC control power applied to the battery power input (1,2), then press and hold the lamp test button, and ensure all 12 LED lights on the front panel light up If defective, return to Thomson Power systems using RMA process
	Faulty Generator power switching device auxiliary switch	Verify Generator side auxiliary switch (G-AUX) n/c contact is closed and is low resistance when Generator switching device is open. Verify TSC 7320 Digital input for Gen Power Switching Device is Open has been activated
	On Service Entrance Rated ATS, Service Disconnect switch is in the "De-Energized" or "Transfer to Neutral" positions.	Switch to the Energized position
	On Service Entrance Rated ATS, Utility Voltage Disconnect switch inside ATS is switched to "Off" position.	Switch Utility Voltage Disconnect switch to the "On" position
Will not transfer to generator source upon failure of utility source	Warm-up time delay function has not timed out yet	Verify TSC 7320 timer setting
	Generator set output circuit breaker which feeds ATS is open	Close generator set output circuit breaker
	Generator supply is not operating at correct voltage or frequency levels.	Verify correct nominal levels the generator should be operating at and compare to TSC 7320 Settings for under/over voltage, voltage phase balance and under/over frequency
	TSC 7320 has incorrect generator voltage or frequency settings for the ATS.	Re-Program TSC 7320 with correct settings as required for voltage or frequency.
	Generator Phase Rotation may not match Utility supply (First Time Transfer).	Check Generator & Utility Voltage Phase rotation matches on TSC 7320 Utility & Generator Voltage Pages. If power cabling has non-matching phase rotation, reverse power conductors on one phase on one of the supplies
	TSC 7320 Generator voltage sensing connection plug (34,35,36,37) is unplugged	Verify all TSC 7320 connectors are fully inserted
	ATS Power Chassis & Voltage Sensing Isolation Plugs (PL12 or PL15) are unplugged	Verify both PL12 & PL15 connectors are fully inserted
	TSC 7320 has "Transfer Fail" alarm activated.	Determine cause of alarm and rectify before resetting the alarm at TSC 7320
Defective ATS mechanism motor	Verify motor does not rotate when 120VAC is applied directly to motor leads. If defective Return to Thomson Power systems using RMA process	

Will not transfer to generator source upon failure of utility source (con't)	A loose control wire connection	Check all wiring connections in the ATS
	Defective TSC 7320 controller	Verify TSC 7320 has 24VDC control power applied to the battery power input (1,2), then press and hold the lamp test button, and ensure all 12 LED lights on the front panel light up If defective, return to Thomson Power systems using RMA process
	Faulty Utility power switching device auxiliary switch	Verify Utility side auxiliary switch (U-AUX) n/c contact is closed and is low resistance when Utility switching device is open. Verify TSC 7320 Digital input for Utility Power Switching Device is Open has been activated
Transfer to generator source without a power failure in the utility source	A Load Test mode has been activated locally or remotely	Check TSC 7320 load test LED status indicators
	An Exercise Test mode has been activated by the TSC 7320 scheduler	Check TSC 7320 status screen for Exercise Test is active
	Utility supply is not operating at correct voltage or frequency levels.	Verify correct nominal levels the utility source should be operating at and compare to TSC 7320 settings for under/over voltage, voltage phase balance and under/over frequency
	TSC 7320 has incorrect utility voltage or frequency settings for the ATS.	Re-Program TSC 7320 with correct settings as required for voltage or frequency.
	Utility power switching device has tripped open due to an over current condition and TSC 7320 "Mains Breaker Tripped" alarm is displayed.	Determine cause of alarm and rectify before TSC 7320 is reset.
	A loose control wire connection	Check all wiring connections in the ATS
	Defective TSC 7320 controller	Verify TSC 7320 has 24VDC control power applied to the battery power input (1,2), then press and hold the lamp test button, and ensure all 12 LED lights on the front panel light up If defective, return to Thomson Power systems using RMA process
Generator does not start or stop when it should	Remote engine control panel is not set to automatic mode	Verify remote engine control panel is set for automatic operation
	Engine start contact is wired incorrectly from ATS to engine control panel	Verify engine start contact is wired correctly from ATS to engine control panel
	TSC 7320 Engine start contact connection plug (30,31) is unplugged	Verify all TSC 7320 connectors are fully inserted

	Defective TSC 7320 controller	Verify TSC 7320 has 24VDC control power applied to the battery power input (1,2), then press and hold the lamp test button, and ensure all 12 LED lights on the front panel light up If defective, return to Thomson Power systems using RMA process
	Engine Start and/or Cooldown timers may be duplicated in both ATS control and Engine control Panel	Disable timers in Engine control panel.
No time delay when there should be	Incorrect TSC 7320 time delay setting	Verify TSC 7320 timer setting
Power is not available at the load terminals but the utility or generator power switching device appears to be closed to a live source	Utility or Generator power switching device has tripped open due to an over current condition.	Power Switching device must be reset by <u>manually</u> operating the ATS mechanism to the other source, then back to the source which was tripped.
	Mechanism has failed to operate the power switching device toggle far enough to close the power switching unit.	Power switching device aux contact failure. Contact Thomson Power system for adjustment procedure or replacement of aux contacts
The transfer switch has completed a transfer, but the motor has overheated and the internal thermal protector has opened	Aux contact failure or improper adjustment	Contact Thomson Power system for adjustment procedure or replacement of aux contacts
TS 7320 Display is not showing any system information	Defective TS 7320 controller	Verify TSC 7320 has 24VDC control power applied to the battery power input (1,2), then press and hold the lamp test button, and ensure all 12 LED lights on the front panel light up If defective, return to Thomson Power systems using RMA process
	TSC 7320 controller is not powered from 24Vdc aux supply	The TSC 7320 controller needs 24Vdc aux power all the time. Verify Low power buffer module provides proper 24Vdc supply to TSC 7320 controller.

NOTE

There are no user serviceable components located on the TSC 7320 printed circuit board. If the TSC 7320 controller is deemed to be defective, they must be returned to the Thomson Power Systems Factory for repair or replacement. Please refer to Product Return Policy section of this manual further information on product return procedures required.

16. REPLACEMENT PARTS

Replacement parts are available for the transfer switch as follows:

NOTE

When ordering replacement parts please provide the following information:

- Transfer Switch Model code (e.g. TS 873AA0200AS)
- Transfer Switch Serial Number (e.g. W-022345)

The above information can be found on the transfer switch equipment rating plate located on the outside of the ATS door

Component Description	Thomson Power Systems Part Number	Comments
TSC 7320 Controller Service Replacement	TSC7320SR	Must change the controller settings via the front panel prior to use. Refer to TSC 7320 Instruction Manual.
Power switching device aux contacts 1 n/o, 1 n/c (all ATS Models)	Contact service for the required parts	Must install and adjust for proper operation before use. Contact Thomson Power Systems Service Dept. for installation/adjustment procedures
Transfer Switch Motor (100A-250A S Style Mechanism) 120V 20 watt 1 PH	007701	Motor is supplied with gear box assembly. Contact Thomson Power Systems Service Department for installation procedures
Transfer Switch Motor (400A-800A S Style	007961	Motor is supplied with gear box assembly. Contact Thomson Power Systems Service

Component Description	Thomson Power Systems Part Number	Comments
Mechanism) 120V 30 watt 1 PH		Department for installation procedures
120VAC 10A Auxiliary Plug-in Relay, 11 pin square	006161	Must ensure coil voltage is correct
24VDC 10A Auxiliary Plug-in Relay, 11 pin square (UX/GX)	004095	Must ensure coil voltage is correct
120VAC Auxiliary Plug-in Timer, 11 pin round	001515	Must ensure coil voltage is correct
100VA Control Transformer	009997	Change PT tabs to match panel voltage before installing

For other parts not listed, please contact Thomson Power Systems.

17. PRODUCT RETURN POLICY

Thomson Power Systems uses a Return Material Authorization (RMA) process. Please complete the [Return Authorization Request Form](#) (available on our web page) for return of goods, warranty replacement/repair of defective parts, or credit consideration and fax to the appropriate department.

Returns only: Email sales@thomsonps.com

Warranty replacement/Warranty Repair: Email support@thomsonps.com

Upon receipt of your request, Thomson Power Systems will confirm with a copy of our Order Acknowledgement via fax advising the RMA number which should be used to tag the defective controller prior to shipment.



18. NOTES





19. PERFORMANCE TEST FORM

This form should be retained by those in charge of the building electrical installation in order to be available to the authority having jurisdiction.

Date	Personnel	Tests performed	Comments
		Interconnection evaluation	
		Grounding point evaluation	
		Fault current test:	
		Ground fault settings - _____	
		Simulated current - _____	
		Results - _____	



APPENDIX “A”

THOMSON POWER SYSTEMS®



NOTE: The following commissioning procedures are provided for general information only pertaining to typical site installations and applications. Contact Thomson Power Systems for further information as may be required.

A) Pre-Energization Checks

1. Verify the generator and utility supply voltages match the model of the ATS ordered. If a different voltage is required, refer to procedure in Appendix B for voltage change programming procedure.
2. Confirm power cable size is correct for the lugs supplied in the transfer switch (line, load, and neutral) and are properly torqued.
3. Confirm transfer switch has been adequately grounded per NEC/CEC requirements.
4. Confirm power cables have been Insulation Resistance Tested to ensure no cross phase connections or conduction to ground.
5. Check to ensure there is no mechanical damage.
6. Check to ensure no packaging materials or tools are left inside the transfer switch.
7. Verify control wiring connected to terminal blocks are properly installed (i.e. no frayed ends, screws are tight, no damage, etc.).
8. Ensure ATS Power Chassis & Voltage Sensing Isolation Plugs (PL12 & PL15) are inserted and all TSC 7320 Controller plugs are inserted prior to operation.
9. Visually verify the transfer switch mechanism is closed in the utility position as indicated on the mechanism cover.
10. Verify correct control wire interconnects have been installed to the generator set auto start/stop controls.

NOTE: The ATS Engine Start contact closes to start the engine and opens to stop the engine.

11. Ensure the inside of the transfer switch is clean from all dust, and other foreign materials.
12. Close ATS enclosure door and tighten all door screws.
13. Visually verify on the transfer switch enclosure that there are no gaps, holes, or potential for water ingress.

APPENDIX “A”

THOMSON POWER SYSTEMS®



TYPICAL TS 870 ATS COMMISSIONING PROCEDURES (S-Style 100A-800A)



B) Equipment Energization

DANGER

HAZARD OF ELECTRICAL SHOCK, EXPLOSION, OR ARC FLASH

This equipment must be serviced only by qualified electrical personnel utilizing safe work practices and appropriate Personal Protective Equipment (PPE). Many components of this equipment operate at line voltage. DO NOT TOUCH. Use only electrically isolated tools. Failure to do so may cause personal injury or death

14. Confirm Utility, Generator and loads can be energized in a safe manner.
15. Energize utility supply and wait approximately 20 seconds for the TSC 7320 controller to successfully perform an initial boot-up process. A Thomson Power Systems Logo will be displayed during the booting process. 

NOTE: Under normal operation, TSC 7320 controller will not re-boot due to use of an external control power reservoir circuit. The Low Power Buffer (LPB) maintains DC control power during Utility power failures, allowing the controller to start the gen and transfer to it without rebooting.

16. Confirm utility voltage on the TSC 7320 DISPLAY Home page is matching with the rating of the ATS. If the voltage is not matching, refer to Appendix B, TS 870 system voltage change procedure of this manual to modify the controller settings. If the voltage is matching, the ATS will automatically transfer to the Utility source.
17. To perform any changes to the TSC 7320 controller settings, refer to PM180 TSC 7320 controller O&M manual or PM173 TS 870 quick start guide for details.
18. Set the TSC 7320 Internal time clock – With the TSC 7320 powered on, Enter the restricted area of the settings, and find the page with the “Display” heading. If the date and time is not listed, the up or down navigation button may need to be pressed to show the setting.
19. Press the center checkmark button and one section will start to flash. Use the up or down navigation keys to change the value of the flashing setting, and the left and right keys to change which part of the setting is going to be changed

APPENDIX “A”

THOMSON POWER SYSTEMS®

	TYPICAL TS 870 ATS COMMISSIONING PROCEDURES (S-Style 100A-800A)
---	--



20. Change all parts of the time and date to match the desired values and press the center checkmark when finished. Hold the center checkmark to exit the editor mode.



21. Verify the status of the following indicator lights on the TSC 7320 front panel:
- Utility Source Green LED is “ON” when the voltage is healthy and available
 - Load on Utility Green LED is “ON” when the load is connected to the utility
22. Run the generator manually and confirm generator voltage on the TSC 7320 display, the voltage is displayed on the “Generator” page. Verify the measured voltage is correct and matches the rating of the ATS.
23. With generator still running, confirm generator phasing matches that of the Utility supply by viewing the “Generator” page, and using the up or down navigation buttons to find the “Gen Phase Sequence” page. If phase rotation does not match, de-energize ATS and re-confirm supply rotation and power wiring is correct.

NOTE

On 3 Phase Systems, the TSC 7320 ATS controller has Phase Rotation miss-match protection. For the ATS to successfully transfer between sources, both the Utility and Generator Source Phase rotation must be matched. Phase rotation on both sources can be either positive rotation (i.e. A-B-C) or negative rotation (C-B-A) via programming selection on the TSC 7320.

24. Verify the TSC 7320 front panel Generator Source green LED is “ON”

APPENDIX “A”

THOMSON POWER SYSTEMS®



TYPICAL TS 870 ATS COMMISSIONING PROCEDURES (S-Style 100A-800A)

25. To confirm automatic starting and load transferring of the generator, perform an On-Load test as described in section M(e). Press the “Test mode” button, and then press the green “Start” button. The generator will start and transfer on load per Automatic Sequence. The following lights on the TSC 7320 front panel should be on: Engine Start, Gen Source LED and Load on Gen LED.
26. To stop the generator and transfer load back to the utility supply, press the “Auto” button to return to auto mode. The load will re-transfer back to the utility power as per Automatic Sequence.
27. Perform a utility power outage test by opening the upstream utility feeder breaker to the ATS. The TSC 7320 front panel Utility available LED will turn off; the generator set will start after the 2-second engine start delay has expired and the generator will start and transfer on load as per Automatic Sequence.
28. Return Utility supply voltage to the ATS by re-closing the upstream utility breaker. The load should re-transfer back to the utility supply as per Automatic Sequence.

APPENDIX “B”

THOMSON POWER SYSTEMS®



TS 870 SYSTEM VOLTAGE CHANGE PROCEDURE

The system voltage change procedure is a 2 step process 1) ATS Potential Transformer Tap Change and 2) TSC 7320 Software Programming. Details of each step are as follows:

A) ATS Potential Transformer Tap Change



DANGER

HAZARD OF ELECTRICAL SHOCK, EXPLOSION, OR ARC FLASH

This equipment must be serviced only by qualified electrical personnel utilizing safe work practices and appropriate Personal Protective Equipment (PPE).

Many components of this equipment operate at line voltage. DO NOT TOUCH. Use only electrically isolated tools.

Install and close all covers before applying power to this equipment

Do not open covers to equipment until ALL power sources are disconnected

1. Ensure all power sources are de-energized and are safely Locked-out from service prior to opening the transfer switch enclosure door.
2. Disconnect AC Sensing and ATS Power Chassis Circuit Isolation Plugs PL12 & PL15.
3. Change voltage transformer primary taps settings as follows to match new system voltage on all potential transformers (PTs). (Refer to wiring schematic diagram below).

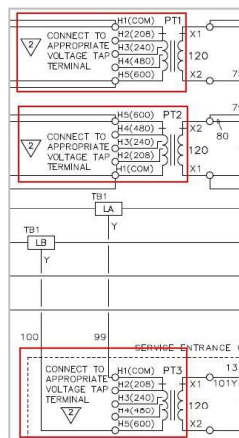

APPENDIX "B"

THOMSON POWER SYSTEMS®



TS 870 SYSTEM VOLTAGE CHANGE PROCEDURE

- Carefully remove the potential transformer high voltage side covers by prying up on the edge of the cover with a ¼" Flat Head Blade screwdriver and lifting off.

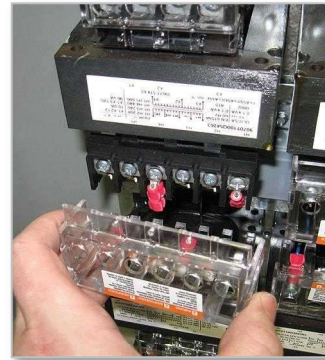
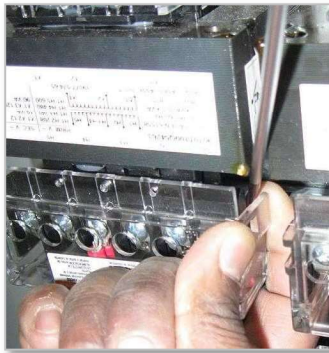
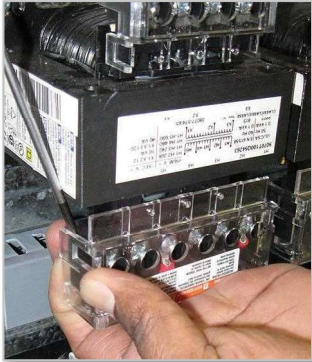

NOTE: You can also use your finger to pry up on the edge of the PT cover.

- Remove the screw on the PT Tap which is the correct voltage selected for the application (i.e. H2-208V, H3-240V, H4-480V or H5-600V)

H6-Not Used H5-600V H4-480V H3-240V H2-208V H1 (Never Changes)

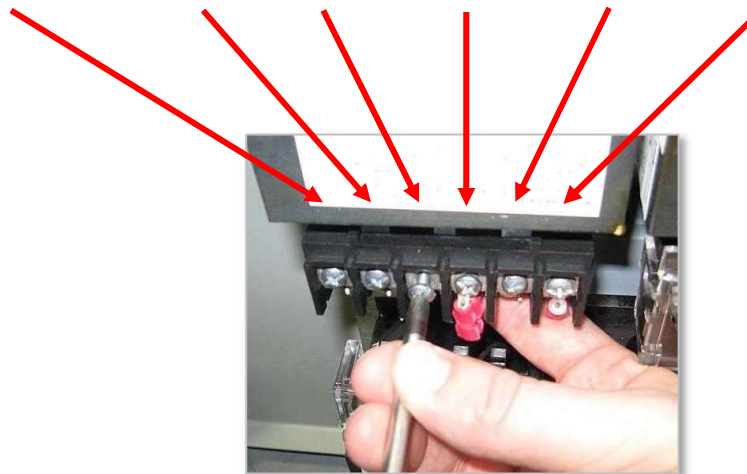

APPENDIX "B"

THOMSON POWER SYSTEMS®



TS 870 SYSTEM VOLTAGE CHANGE PROCEDURE

CAUTION: Brace PT terminal block with your hand when loosening or tightening ANY screws.

6. Remove the screw and red ring terminal connected to the incorrect (existing) PT voltage terminal. Install the screw and red ring terminal to the new selected PT Tap Terminal based on required voltage and tighten while supporting the terminal block. Make sure the ring terminal is not misaligned or the PT cover will not fit back on.



7. Install the extra screw back onto the old PT location and tighten.



CAUTION

Confirm that PT screws are correctly tightened, and do not put strain on the PT Tap wires.

8. Replace the PT cover. PT covers should 'snap' in place, confirm they are installed correctly by gently "twisting" the PT cover. DO NOT use excessive force.
9. Repeat the steps 1 to 8 for all Potential Transformers.

APPENDIX “B”

THOMSON POWER SYSTEMS®



TS 870 SYSTEM VOLTAGE CHANGE PROCEDURE

B) TSC 7320 Voltage Change Procedure

To change system voltage on the TSC 7320 controller, the transfer switch can be energized or de-energized to change the system voltage. If the transfer switch is energized, please ensure the mechanism is in the utility position, and place the controller in “Stop” mode by pushing the red button in the lower left corner. It is recommended to de-energize the transfer switch to mitigate any hazardous conditions. Always proceed with caution and follow the steps below to change the voltage.

NOTE: All system voltage changes are ONLY done via connecting a designated wire to a different terminal on the TSC 7320 controller. All alarm values are ONLY changed via software programming.

1. **Locating the PIN:** First find PINs 14 to 20 on the backside of the TSC 7320 controller. There will be a wire connected to PIN 14, and that wire will have a label specifying it is the voltage selection wire.

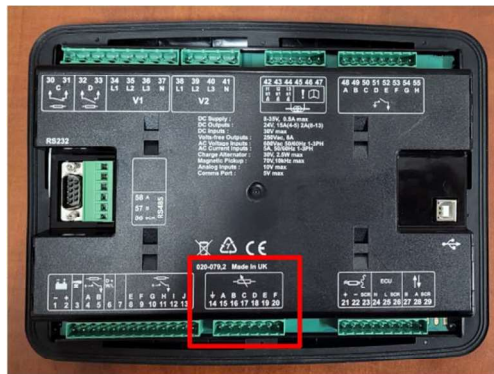

2. **Removing the wire:** Using a small flat head screwdriver, loosen the terminal screw for PIN 14, and remove the voltage selection wire out of PIN 14.

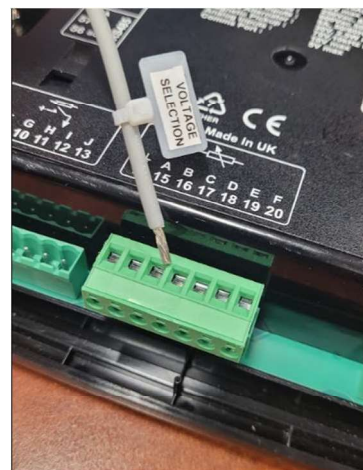

APPENDIX “B”

THOMSON POWER SYSTEMS®



TS 870 SYSTEM VOLTAGE CHANGE PROCEDURE

3. **Choosing voltage configuration:** There are 5 separate inputs that dictate the different configurations, and they are listed in the table below. Select one of the options below based on the ATS requirements.

Inputs	Pin No.	Descriptions
GROUND	14	480V 3PH 4W CONFIGURATION
ANALOGUE INPUT A	15	120/240V 1PH 3W CONFIGURATION
ANALOGUE INPUT B	16	208V 3PH 4W CONFIGURATION
ANALOGUE INPUT C	17	240V 3PH 4W CONFIGURATION
ANALOGUE INPUT D	18	600V 3PH 4W CONFIGURATION
ANALOGUE INPUT E	19	110V 1PH 2W CONFIGURATION

4. **Inserting the wire:** Insert the voltage selection wire into the desired terminal and tighten the screw on the terminal. The terminals are rated for 4.5in-lbs of torque, do NOT over tighten the terminal screw. The photo below shows the 600V 3PH 4W configuration.

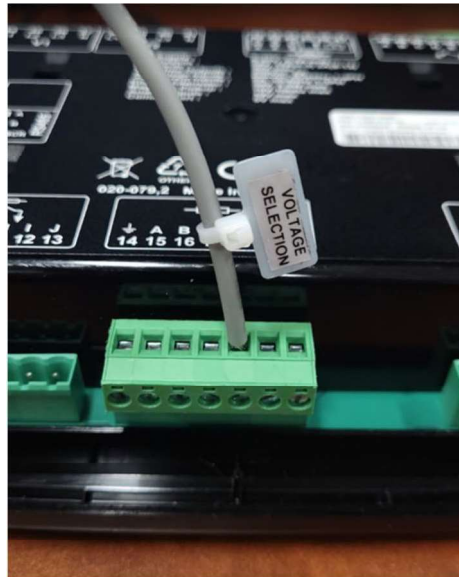

5. **Checking config:** If the panel is not energized, turn on the power and energize the transfer switch. After the controller boots-up, use the left or right navigation keys to find the “Mains” page, and use the up and down navigation keys to find the “Active Config” page. If the controller is properly registering the changed input, the screen should display the desired configuration, and NOT the default 480V configuration. In this case, the 600V configuration has been selected.

APPENDIX “B”

THOMSON POWER SYSTEMS®



TS 870 SYSTEM VOLTAGE CHANGE PROCEDURE

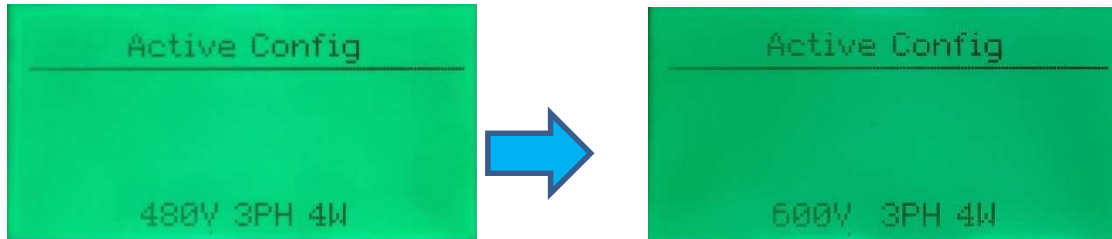

6. **Complete:** The voltage change procedure is now complete. If the voltage settings need to be adjusted from their default values, please refer to PM180 TSC 7320 controller O&M manual or PM173 TS 870 quick start guide for details on entering the restricted area of the settings, and how to change values. Otherwise, proceed to energize the ATS to confirm proper operation as per procedure listed in Appendix A.

APPENDIX "C"

THOMSON POWER SYSTEMS®



SEISMIC CERTIFICATE



Seismic Certification

Thomson Technology – Automatic Transfer Switches TS 840, 870, 880 Approved for use in Seismic Applications

Thomson Technology has seismically certified its line of **Automatic Transfer Switches** including all models of **TS 840, 870, 880**. The certification was done by shake-table testing according to the nationally recognized standard, AC156. The standard covers seismic design requirements for non-structural components according to IBC 2006 and ASCE7-05.

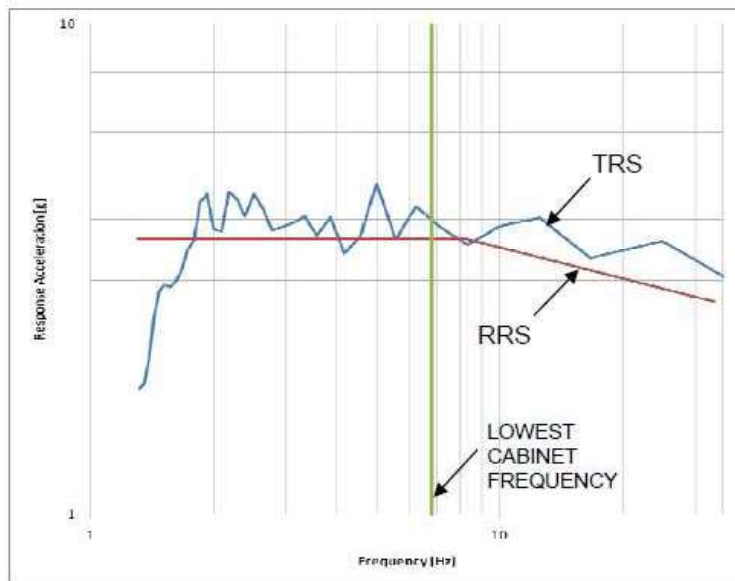

Dr. Carlos E. Ventura, PE
Director, TVP Engineering Ltd.
Certifying Company



Norm Schmidt
Vice President, Engineering and Administration
Thomson Technology

Shake-table tests were performed at Alpha Seismic and Environmental Test Laboratory and the Earthquake Engineering Research Facility, University of British Columbia. The figure shows a representative Test Response Spectrum (TRS) plotted with 5% damping against the AC156 Required Response Spectrum (RRS) with a S_d value of 342%. For more details, please refer to the certification notes.



Thomson Power Systems

4916 - 275th Street
Langley, BC, Canada V4W 0A3

Customer Support: 604-888-0110
Toll Free: 1-888-888-0110
Sales Email: sales@thomsonps.com
Service Email: support@thomsonps.com

For Preventative Maintenance or Extended Warranty information contact our Service Department at 604-888-0110 or email support@thomsonps.com

PM175 REV 0 23/02/10

Thomson Power Systems and Regal are trademarks of Regal Beloit Corporation or one of its affiliated companies.

©2018 Regal Beloit Corporation, All Rights Reserved.





1. **LIMITED WARRANTY**

This warranty applies to new TS 880, TS 870, TS 840, TS 970, TS 930, QCP & 3PTS series ("Product") manufactured by Thomson Technology Power Systems ULC dba Thomson Power Systems.

Thomson Power Systems warrants that it will repair or replace, at Thomson Power Systems sole discretion, any Product that proves to have a defect in material or workmanship during the time period of effectiveness of this limited warranty, provided that initial inspection and start-up of the installation are conducted by qualified personnel.

Any parts or equipment that the purchaser/owner claims to be defective must be returned to Thomson Power Systems. Repair, replacement or appropriate adjustment will be made upon examination, inspection and testing by Thomson Power Systems, if the part is determined to be defective under normal use.

Time limitations of Limited Warranty

This coverage shall become effective upon the date of product shipment from Thomson Power Systems and shall expire 24 months thereafter.

Extended Limited Warranty Coverage

At the Buyers election warranty protection can be extended as follows:

- 3 year warranty – extended 12 months beyond the standard 24 months from date of shipment.
- 5 year warranty – extended 36 months beyond the standard 24 months from date of shipment.

This option is available for purchase within the first 12 months of the warranty period.

2. **THOMSON POWER SYSTEMS'S RESPONSIBILITIES UNDER THE LIMITED WARRANTY**

Thomson Power Systems shall be responsible for:

- A) The repair or replacement, at Thomson Power Systems election, of defective Products, which are eligible under this warranty. Any labour associated with the warranty procedure shall be provided by Thomson Power Systems or its Authorized Service Representative (ASR), to a maximum of four (4) hours. In the event that labour on site may exceed this maximum time allowable, additional charges must be authorized by Thomson Power Systems.
- B) Travel time and mileage expenses covered by this limited warranty are limited to a maximum of four (4) hours **regular** time labour and 200 kilometers (125 miles). Any expenses in excess of this maximum allowance shall be to the account of the Owner, and will be charged at Thomson Power Systems standard rates (per Thomson Power Systems Price List PL017). In the event that an ASR performs the work, expenses in excess of this maximum allowance shall be to the account of the Owner, paid to the ASR charged at their applicable rates.
- C) In the event that an ASR performs the work, costs for one technician only will be covered under this warranty. Multiple technicians may be eligible for coverage only if preauthorized by Thomson Power Systems prior to the performance of the service work.
- D) In the event that an ASR performs the work, costs for one occurrence per claim will be covered under this warranty. Additional costs for repeat attendances to



correct the same deficiency/problem may be eligible for coverage only if preauthorized by Thomson Power Systems prior to the repeat of the service work.

- E) For warranty consideration or approval, claims must be submitted to Thomson Power Systems within one (1) week of warranty procedure site work.
- F) Whenever possible, reasonable measures must be made to notify Thomson Power Systems and perform remote technical troubleshooting at the earliest opportunity.

3. OWNER'S RESPONSIBILITIES UNDER THE LIMITED WARRANTY

Owner shall be responsible for:

- A) Proper operation and maintenance of the Product.
- B) Maintaining a detailed record of all maintenance or system repairs performed.
- C) Making the warranted Product available to Thomson Power Systems or its designated ASR for warranty repair, during normal business hours.
- D) Any labour charge differential incurred for overtime labour. Overtime labour charge differential shall be the difference between Thomson Power Systems regular and overtime rates.
- E) Any costs incurred as the result of the removal or reinstallation of the Products or Systems undertaken by the Owner or the Owner's representative.
- F) Any administrative costs borne by the Owner or the Owner's representative as a result of a warranted failure.
- G) All costs of transportation, lodging, meals (except those allowed in paragraph 2B) incurred by Thomson Power Systems.
- H) Returning all defective product to Thomson Power Systems for examination, inspection and testing. **All freight charges are at the Owner's expense.**

4. LIMITATION OF THOMSON POWER SYSTEMS'S OBLIGATIONS UNDER THE LIMITED WARRANTY

- A) The obligations of Thomson Power Systems under this limited warranty shall be voided, and Thomson Power Systems shall not be responsible for:
 - i) Failure resulting from improper handling, storage or installation.
 - ii) Failure resulting from Owner or operator abuse or neglect.
 - iii) Failure resulting from modifications or repairs not authorized by Thomson Power Systems in writing.
 - iv) Failure due to normal wear and tear, or as a result of lack of routine maintenance.
 - v) Damage due to negligent maintenance practices such as, but not limited to:

- a) Failure to turn off AC power to battery charger before disconnecting battery from the system.
 - b) Failure to disconnect all sources of power before servicing the Product.
 - c) Application of voltage source not suitable for the Product.
 - d) Use of wiring not suitable for the Product.
 - vi) Failure to perform scheduled maintenance such as required by regulatory authorities or as prescribed in product manuals.
 - vii) Failure attributed to abnormal voltage or current levels, including transients.
 - viii) Failure of Owner to provide written notice and details of a defect to Thomson Power Systems in a timely manner.
 - ix) Failure to make Products available to Thomson Power Systems or its ASR in a timely manner.
- B) Thomson Power Systems shall not be responsible for any administrative costs associated with the warranty procedure.
- C) Thomson Power Systems shall not be responsible for costs related to substitute or temporary equipment, which Owner provided in conjunction with the warranted repair.
- D) Thomson Power Systems shall not be responsible for any contingent costs related to failure of the Product, including damage to property and loss of use of property.

5. **RETURN OF PRODUCTS UNDER LIMITED WARRANTY**

No Product may be returned to Thomson Power Systems without prior written consent. Thomson Power Systems will not accept shipping charges, for the return of defective Product to its factory or authorized service outlet, or the return of repaired or replacement Product to the Owner. Return Material Authorization (RMA) Request form (SVF028) is available from our website at www.thomsonps.com.

Thomson Power Systems is not liable nor responsible for items returned without authorization. Delivery may be refused, or items disposed of without notice. Collect and COD shipments will be refused.

6. **APPLICABILITY AND EXPIRATION OF LIMITED WARRANTY**

The warranties set out above are extended to Owners of the Product.

The foregoing sets forth Thomson Power Systems only obligations and Owner's exclusive remedy for breach of warranty, whether such claims are based on breach of contract, tort (including negligence and strict liability), or other theories. The foregoing is expressly in lieu of other warranties whatsoever expressed, implied, or statutory, including without limitation, the implied warranties of merchantability and fitness.

Notwithstanding the preceding, Thomson Power Systems is not liable for any direct, special, incidental or consequential damages (whether denominated in contract, tort, strict liability, negligence or other theories) arising out of the use of any Products.

There is no other warranty.