

Builder must check correctness of this drawing PRIOR to erection of this system. This drawing is conceptual and should be used with the Architectural plans to insure proper joist and beam placement. Stairways may be drawn small to allow for adjustments in the field.

BEARING WALLS AND POINT LOADS FROM FLOORS ABOVE DIRECTLY EFFECT SLAB OR FLOORS BELOW AND SHOULD BE ADDRESSED PRIOR TO INSTALLATION OF SLAB OR FLOORS BELOW IF NOT DIRECTLY ADDRESSED IN THESE LAYOUTS

Symbols for reference only. Framers to verify fixture locations for proper joist adjustments.

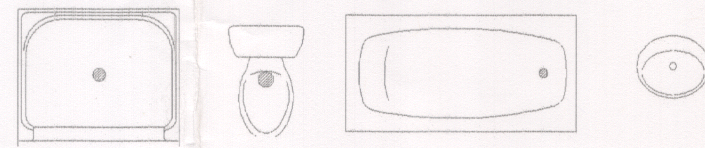

DN01 DO NOT cut, notch or drill flanges

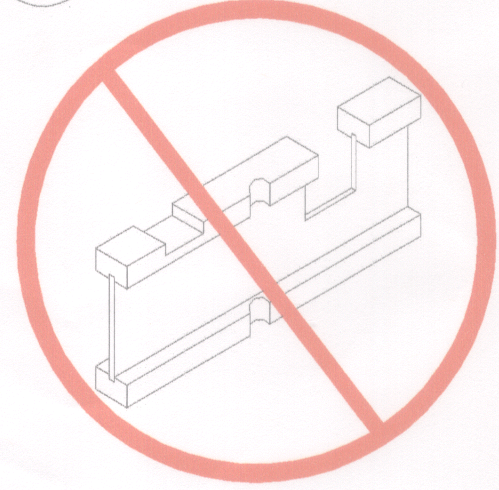

DN03 DO NOT support joist by top flange and/or web.

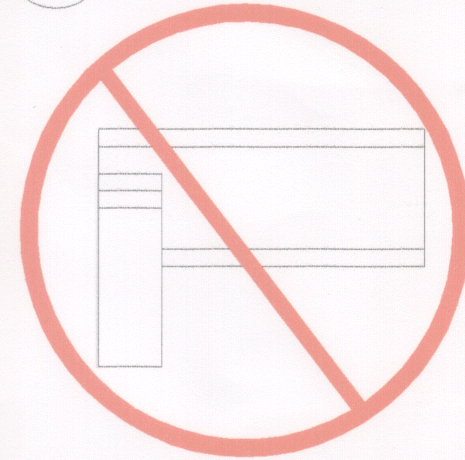

Sill plate to be properly anchored to steel beam

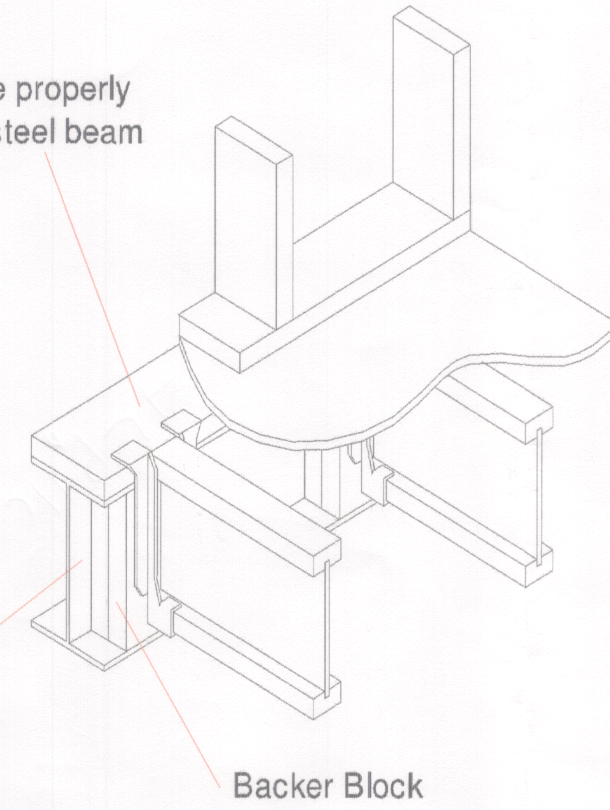

Steel Beam

Backer Block

Connector Summary			
PlotID	Qty	Manuf	Product
Hu1	1	Simpson	GLTV 5.516
Hu2	2	Simpson	HGUS7.25/14
Hu3	29	Simpson	ITS2.37/16
Hu4	230	Simpson	ITS2.37/16
Hu5	2	Simpson	ITS2.37/16

Products				
PlotID	Net Qty	Product	Length	Piles
1	27	16" BC10 6000s-1.8	24' 0"	1
2	195	16" BC10 6000s-1.8	22' 0"	1
3-2	2	16" BC10 6000s-1.8	22' 0"	2
4	125	16" BC10 6000s-1.8	20' 0"	1
5	7	16" BC10 6000s-1.8	12' 0"	1
6	144	16" BC10 6000s-1.8	10' 0"	1
7	1	16" BC10 6000s-1.8	4' 0"	1
8	17	16" BC10 90s-2.0	22' 0"	1
9-3	6	1-3/4" x 14" VERSA-LAM® 2.0 3100 SP	10' 0"	3
10-3	3	1-3/4" x 16" VERSA-LAM® 2.0 3100 SP	24' 0"	3
11-3	6	1-3/4" x 16" VERSA-LAM® 2.0 3100 SP	22' 0"	3
12-3	3	1-3/4" x 16" VERSA-LAM® 2.0 3100 SP	18' 0"	3
13-4	32	1-3/4" x 16" VERSA-LAM® 2.0 3100 SP	18' 0"	4
14-3	3	1-3/4" x 16" VERSA-LAM® 2.0 3100 SP	16' 0"	3
15-4	8	1-3/4" x 16" VERSA-LAM® 2.0 3100 SP	16' 0"	4
16-3	3	1-3/4" x 16" VERSA-LAM® 2.0 3100 SP	14' 0"	3
17-3	3	1-3/4" x 16" VERSA-LAM® 2.0 3100 SP	12' 0"	3
18	1	1-3/4" x 16" VERSA-LAM® 2.0 3100 SP	10' 0"	1
19	1	STEEL BEAM BY OTHERS	30' 0"	1
20	1	2" x HEADER	8' 0"	1
21	1	2" x HEADER	6' 0"	1
Ca1	3	1-1/8" x 16" BC RIM BOARD OSB	22' 0"	1
Ca2	2	1-1/8" x 16" BC RIM BOARD OSB	12' 0"	1
Ca3	7	1-1/8" x 16" BC RIM BOARD OSB	10' 0"	1
Ca4	2	1-1/8" x 16" BC RIM BOARD OSB	4' 0"	1
Ca5	2	1-1/8" x 16" BC RIM BOARD OSB	2' 0"	1
Ca2	80	1-1/8" x 16" BC RIM BOARD OSB	12' 0"	1

NOTE: ALL MEASUREMENTS TO BE VERIFIED IN THE FIELD.

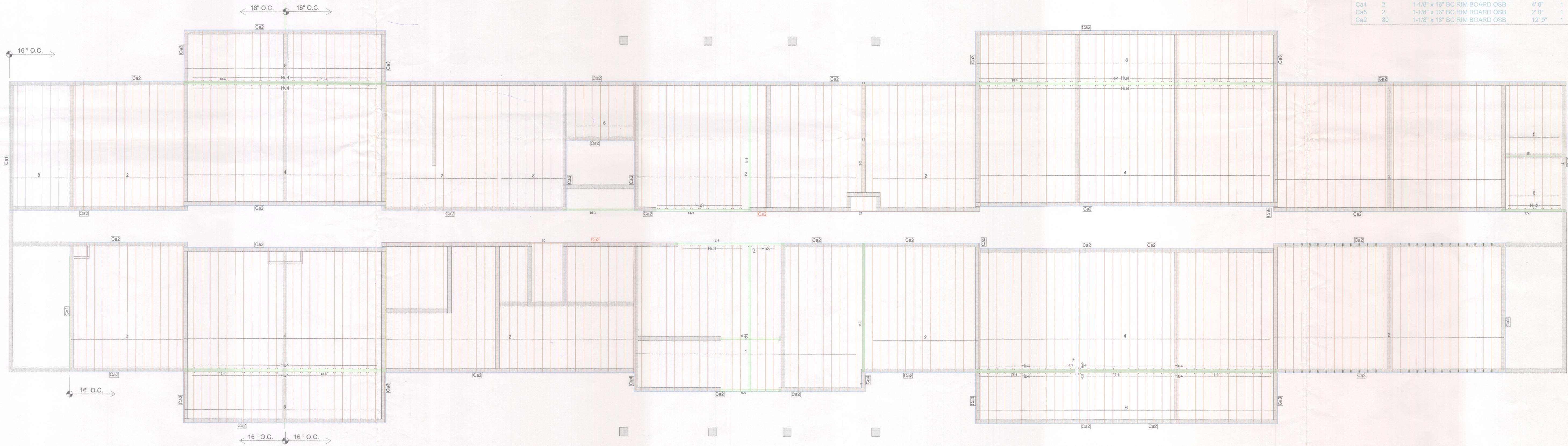

Floor 1

B12-A Side Loaded Connection Double & Triple 1-3/4" Versa-Lam® Nail Pattern

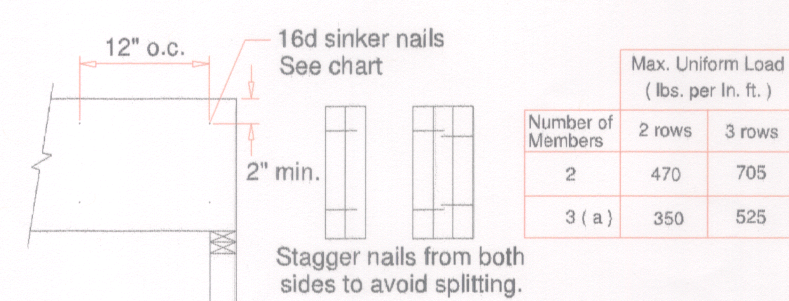

(a) Nail pattern for 3 - piece member must occur on both sides. Nail values may be increased by 15% for snow load roofs and by 25% for non - snow load roofs where building code allows.

DN04 DO NOT cut holes near bearing support

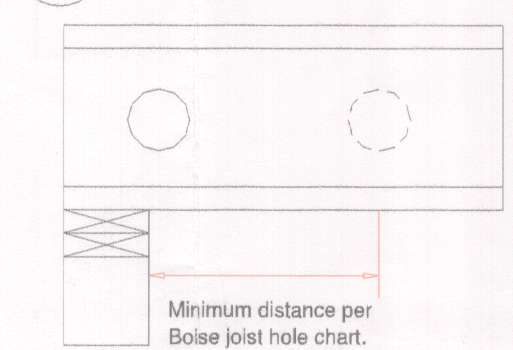

F27 Top Flange Joist hanger

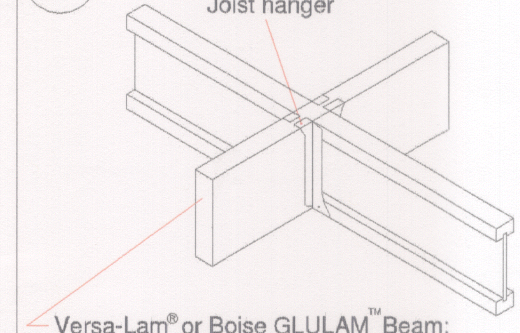

Versa-Lam® or Boise GLULAM™ Beam: (3-1/8" Min. width for ITT, THO hangers) (5-1/8" Min. width for all other top flange hangers)

F27 Boise Joist TF Hanger Both Sides

F13-D

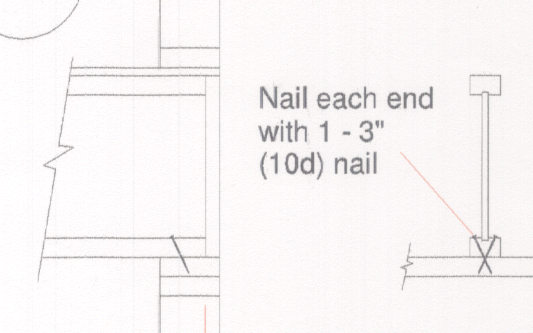

1 1/2" minimum end bearing length at all floor and roof details.

F27-A Top Flange Joist hanger

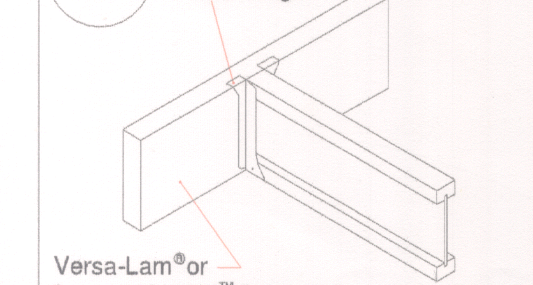

Versa-Lam® or Boise GLULAM™ Beam: (1-3/4" Min. width for ITT, THO hangers) (3-1/8" Min. width for all other top flange hangers)

F27 Boise Joist TF Hanger One Side

F07

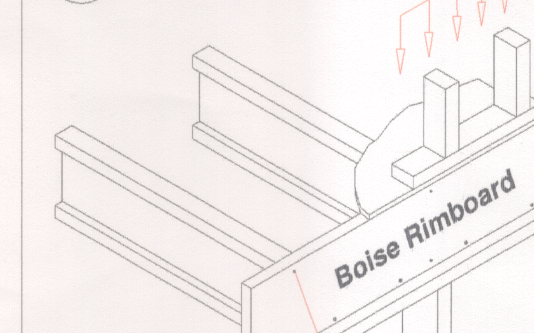

Nail Boise Rimboard to BC® joist with 8d nail into each flange.

16" o.c.

Abita Lumber - Mainstay Suites - 700 Main St. Hackberry

BC FRAMER
Scale: N.T.S.
Date: 6-10-16
By: Ronnie Talley
File: 21271
DWG:
Sheet: 1/1