

# RAWLIN CARTER PRUDENTIAL FINANCIAL ADVISOR

## 1720 W 21ST AVENUE CITY OF COVINGTON, LA.

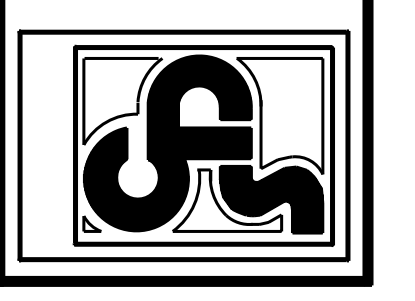


NOTE: ALTHOUGH EVERY EFFORT HAS BEEN MADE IN THESE DRAWINGS, THE ARCHITECT ASSUMES NO LIABILITY FOR CHECKING THE PLANS FOR CONSTRUCTION ERRORS BEFORE BEGINS CONSTRUCTION BEGINS.



**DARBY CLARKE**  
ARCHITECT AIA & NCARB

**CLARKE'S DESIGN SERVICE, LLC.**  
PROJECT DESIGNERS:  
1597 THIRD STREET SUIDELL, LA 70458  
WWW.CLARKEDESIGN.COM (985) 641-0531



**RAWLIN CARTER**  
PRUDENTIAL FINANCIAL ADVISOR  
1720 W 21ST AVENUE  
CITY OF COVINGTON, LA.

**CODE:**  
7408  
**DATE:**  
03-25-26  
**DESCRIPTION:**  
COVER SHEET & GENERAL NOTES & IBC DATA  
**SHEET:**  
COVER SHEET

**CONSTRUCTION NOTES**

01 - GENERAL REQUIREMENTS  
01 THE CONTRACTOR SHALL EXAMINE AND BECOME FAMILIAR WITH ALL CONTRACT DOCUMENTS IN THEIR ENTIRETY. SURVEY FOR PROJECT AND BECOME FAMILIAR WITH THE EXISTING CONDITIONS AND SCOPE OF WORK. ALL COSTS SUBMITTED SHALL BE BASED ON THOROUGH KNOWLEDGE OF ALL WORK AND MATERIALS REQUIRED. ANY DISCREPANCY AND/OR UNCERTAINTY AS TO WHAT MATERIAL OR PRODUCT IS TO BE USED, SHALL BE VERIFIED WITH THE OWNER OR DESIGNER.  
02 THE MATERIALS, PRODUCTS AND EQUIPMENT DESCRIBED IN THE BIDDING DOCUMENTS ESTABLISH A STANDARD OF REQUIRED FUNCTION, DIMENSION, APPEARANCE AND QUALITY TO BE MET BY ANY PROPOSED SUBSTITUTION.  
03 THE CONTRACTOR SHALL BE SOLELY RESPONSIBLE FOR CONSTRUCTION MEANS, METHODS, TECHNIQUES, SEQUENCES, AND PROCEDURES REQUIRED FOR SAFE EXECUTION AND COMPLETION OF WORK, AND FOR INITIATING, MAINTAINING AND ENFORCING ALL SAFETY PRECAUTIONS AND PROGRAMS IN CONNECTION WITH THE WORK.  
04 CONTRACTOR SHALL PROVIDE A COMPLETE AND FINISHED BUILDING, READY FOR OCCUPANCY FULLY CLEANED TO THE SATISFACTION OF THE OWNER.  
05 ANY ERRORS, OMISSIONS OR INCONSISTENCIES IN THESE DRAWINGS OR ANY VARIATIONS OR AMBIGUITIES BETWEEN THESE DRAWINGS AND ACTUAL SITE AND CONSTRUCTION CONDITIONS, REQUIREMENTS SHALL BE BROUGHT TO THE ATTENTION OF THE DESIGNER.  
06 IN THE EVENT OF ANY DISCREPANCY CONTAINED WITHIN THE CONTRACT DOCUMENTS, THIS BID SHALL BE SUBMITTED FOR THE MOST COSTLY CONDITION. NO ADDITIONAL COST TO OWNER SHALL BE DUE TO SUCH DISCREPANCIES.  
07 CONTRACTOR SHALL VERIFY ALL DIMENSIONS IN THE FIELD AND NOTIFY THE DESIGNER OF ANY DISCREPANCIES PRIOR TO CONSTRUCTION.  
08 ALL CONSTRUCTION SHALL COMPLY WITH ALL APPLICABLE STATE & LOCAL CODES.  
09 THE GENERAL BUILDING PERMIT(S) SHALL BE OBTAINED AND PAID FOR BY THE OWNER PRIOR TO CONSTRUCTION. THE GENERAL CONTRACTOR SHALL OBTAIN AND PAY FOR ALL OTHER PERMITS, CERTIFICATES, AND APPROVALS REQUIRED IN CONNECTION WITH ALL WORK UNDER THESE CONTRACT DOCUMENTS. THE CONTRACTOR SHALL COMPLY WITH ALL LAWS, ORDINANCES, RULES & REGULATIONS OF ALL AUTHORITIES HAVING JURISDICTION.  
10 THE GENERAL CONTRACTOR IS RESPONSIBLE FOR COORDINATING ALL WORK WITH ALL UTILITY COMPANIES.  
11 CONTRACTOR TO INCLUDE IN HIS PRICE ALL COSTS AND FEES REQUIRED TO BRING WATER, ELECTRICITY, CABLE & TELEPHONE TO THE BUILDING.  
12 THERE SHALL BE NO DEVIATION FROM THE SPECIFICATIONS AND PLANS WITHOUT WRITTEN APPROVAL OF THE OWNER, DESIGNER AND/OR ENGINEER.  
13 ALL WORK AND EQUIPMENT TO BE FULLY GUARANTEED FOR ONE (1) YEAR FROM THE DATE OF ISSUE OF CERTIFICATE OF SUBSTANTIAL COMPLETION UNLESS SPECIFICATIONS CALL FOR AN INCREASED TIME.  
14 CONTRACTOR SHALL COORDINATE HIS WORK WITH ALL OTHER TRADES. NOTIFY OWNER & ARCHITECT OF ANY DISCREPANCIES PRIOR TO CONSTRUCTION.  
15 CONTRACTOR SHALL VERIFY ALL MEASUREMENTS AT SITE AND BE RESPONSIBLE FOR ACCURACY AND CORRECTNESS OF SAME.  
16 THE CONTRACTOR SHALL EMPLOY AS REQUIRED BY OWNER OR GOVERNING AUTHORITIES, AN APPROVED TESTING LABORATORY TO MAKE ALL TESTS FOR CONCRETE, SOIL, COMPACTION AND WELDING TO ENSURE COMPLIANCE WITH PLANS, SPECIFICATIONS, STANDARDS AND CODES. REFER TO CONCRETE SPECIFICATIONS FOR FREQUENCY OF TESTING REQUIRED. COSTS SHALL BE INCLUDED IN THE CONTRACT.  
17 REMOVE RUBBISH FROM THE PREMISES AS OFTEN AS NECESSARY TO MAINTAIN SAFE & CLEAN SITE.  
18 CLEAN PROJECT SITE AND WORK AREAS DAILY, INCLUDING COMMON AREAS. COORDINATE PROGRESS CLEANING FOR JOINT USE AREAS WHERE MORE THAN ONE INSTALLER HAS WORKED. ENFORCE REQUIREMENTS STRICTLY. DISPOSE OF MATERIALS LAWFULLY.  
19 ANY WORK NOT EXPLICITLY REFERRED TO IN THE CONSTRUCTION DOCUMENTS, BUT REQUIRED TO COMPLETE THE WORK DEPICTED SHALL BE PROVIDED BY THE CONTRACTOR.  
20 REFER TO CIVIL ENGINEER'S PLANS FOR LOCATION OF SIDEWALKS, FENCES & DETAILS, FIRE HYDRANT LOCATIONS, CURB CUTS, DIMENSIONAL CONTROL PLAN & GRADING, UTILITIES (SEWER, WATER, ELECTRICAL, CABLE, TELEPHONE, ETC.)  
21 PROVIDE PRODUCTS & ACCESSORIES OF SAME KIND FROM A SINGLE SOURCE.  
22 DELIVER, STORE & HANDLE PRODUCTS ACCORDING TO MANUFACTURERS WRITTEN INSTRUCTIONS, USING MEANS & METHODS THAT WILL PREVENT DAMAGE, DETERIORATION & LOSS (INCLUDING THEFT).  
23 SCHEDULE DELIVERIES TO MINIMIZE LONG-TERM STORAGE & TO PREVENT OVERCROWDING OF THE CONSTRUCTION SITE.  
24 PROVIDE PRODUCTS AND EQUIPMENT COMPLETE W/ ACCESSORIES, TRIM, FINISH AND OTHER DEVICES & COMPONENTS NEEDED FOR A COMPLETE INSTALLATION & THE INTENDED USE & EFFECT.  
25 UNLESS OTHERWISE INDICATED, OWNER WILL SELECT COLOR, PATTERN & TEXTURE OF ANY PRODUCT FROM MANUFACTURER'S FULL RANGE OF OPTIONS.  
26 CONTRACTOR TO EXAMINE SUBSTRATES & CONDITIONS FOR COMPLIANCE W/ MFR'S WRITTEN REQUIREMENTS INCLUDING, BUT NOT LIMITED TO: SURFACES THAT ARE SOUND, LEVEL & PLUMB; SUBSTRATES WITHIN INSTALLATION & FINISHING TOLERANCES; SURFACES THAT ARE SMOOTH, CLEAN & FREE OF DELETERIOUS SUBSTANCES; AND APPLICATION CONDITIONS WITHIN ENVIRONMENTAL LIMITS. DO NOT PROCEED WITH INSTALLATION UNTIL UNSATISFACTORY CONDITIONS HAVE BEEN CORRECTED.  
27 PREPARE SUBSTRATES & ADJOINING SURFACES ACCORDING TO MFR'S WRITTEN INSTRUCTIONS, INCLUDING, BUT NOT LIMITED TO, THE APPLICATION OF PRIMER AND SEALERS.  
28 - EXISTING CONDITIONS  
01 CONTRACTOR TO BE FAMILIAR WITH EXISTING SITE CONDITIONS AND TO COORDINATE W/ DESIGNER TO ENSURE COMPLIANCE WITH ALL RECOMMENDATIONS.  
29 - CONCRETE  
01 REFER TO STRUCTURAL DRAWINGS, NOTES & SPECIFICATIONS ON SHEETS. IF ANY NOTES CONTAIN HEREIN CONFLICT, THE MOST STRICT REQUIREMENT TO BE UPHOLD. CONTACT DESIGNER IMMEDIATELY WITH ANY SUCH CONFLICTS.  
02 ALL WORK TO BE IN STRICT ACCORDANCE W/ LATEST EDITIONS OF ACI 301, 302 & 318 & ALL APPLICABLE CODES & STANDARDS.  
03 MINIMUM DESIGN CRITERIA: ALL CONCRETE TO HAVE MINIMUM COMPRESSIVE STRENGTH OF 4,000 PSI AT 28 DAYS UNLESS NOTED OTHERWISE; NO CHLORIDES ALLOWED.  
04 STEEL REINFORCING BARS: ASTM A615 GRADE 60  
05 WELDED WIRE FABRIC (WWF) SHEETS: ROLL TYPE WWF SHALL NOT BE USED. ASTM A185 W/ MINIMUM YIELD STRENGTH = 60 KSI. WWF SHALL BE PLACED AT MID-DEPTH OF SLAB.  
06 LAPS & SPICES: ALL REINFORCING LENGTHS FOR REINFORCING STEEL SHALL COMPLY W/ THE ACI MANUAL OF STANDARD PRACTICE, DETAILS AND DETAILING OF CONCRETE REINFORCEMENT, ACI 318, ACI 315, & CRSI STANDARDS.  
07 PLACEMENT: CLEARANCES & MINIMUM CONCRETE COVER FOR REINFORCING STEEL SHALL BE PROVIDED IN ACCORDANCE W/ ACI 318.  
08 SLAB ON GRADE AREAS TO BE CONSTRUCTED OVER 6" (MIN.) LAYER OF COMPACTED AGGREGATE (CRUSHED LIMESTONE, PEA GRAVEL, COARSE SAND OR CRUSHED CONCRETE ARE ACCEPTABLE) UNLESS OTHERWISE NOTED.  
09 PROVIDE 15 MIL (MIN.) VAPOR RETARDANT BARRIER UNDER ALL INTERIOR SLABS UNLESS OTHERWISE NOTED.  
30 - MASONRY  
01 NOT USED  
31 - METALS  
01 REFER TO STRUCTURAL DRAWINGS, NOTES & SPECIFICATIONS ON SHEETS PREPARED BY STRUCTURAL ENGINEER. IF ANY NOTES CONTAIN HEREIN CONFLICT, THE MOST STRICT REQUIREMENT TO BE UPHOLD. CONTACT DESIGNER IMMEDIATELY WITH ANY SUCH CONFLICTS.  
02 ALL WORK UNDER THIS SECTION SHALL BE PERFORMED ENTIRELY UNDER ONE SUB-CONTRACT. THE SCOPE OF WHICH SHALL INCLUDE THE PRODUCTION OF SHOP DRAWINGS, THE FABRICATION OF ALL COLD-FORMED STEEL MEMBERS AND THE ERECTION OF ALL COLD-FORMED STEEL MEMBERS.  
03 WORK IS TO INCLUDE ALL COLD-FORMED STEEL FRAMING AS SHOWN ON THE DRAWINGS, AS SPECIFIED HEREIN AND AS NEEDED FOR A COMPLETE AND PROPER INSTALLATION, INCLUDING ALL BRACING, WELDS, FASTENERS, BEARING PLATES, ANCHOR ACCESSORIES AND OTHER MISCELLANEOUS COMPONENTS REQUIRED FOR A COMPLETE CONSTRUCTION.  
04 ALL COLD-FORMED STEEL SHAPES SHALL BE FABRICATED & ERECTED IN ACCORDANCE WITH LATEST AMERICAN INSTITUTE OF STEEL CONSTRUCTION (AISC) OTHER APPLICABLE CODES & STANDARDS.  
05 COLD-FORMED STEEL MEMBERS SHALL BE NEW SECTIONS IN ACCORDANCE WITH SIZES SPECIFIED ON THE DRAWINGS THAT CONFORM TO THE CURRENT SPECIFICATIONS OF ASTM A1017, GRADE 55.  
06 THE GENERAL CONTRACTOR IS TO VERIFY THE SIZES AND LOCATIONS OF ALL REQUIRED WALL, CEILING AND ROOF OPENINGS. EQUIPMENT SUPPORTS, ETC. WITH THE VARIOUS SUBCONTRACTORS. ANY CONDITIONS WHICH REQUIRE REVISIONS OR ADDITIONS TO THE FRAMING ARE TO BE BROUGHT TO THE ATTENTION OF THE ARCHITECT AND STRUCTURAL ENGINEER PRIOR TO ANY CONSTRUCTION. ANY COST FOR THE REQUIRED CHANGES WILL BE BORNE BY THE GENERAL CONTRACTOR.

**CONSTRUCTION NOTES**

07 THE CONTRACTOR SHALL MAKE MEASUREMENTS IN THE FIELD TO VERIFY OR SUPPLEMENT DIMENSIONS SHOWN ON THE DRAWINGS, AND CONTACT THE RESPONSIBLE FOR PROPER MEASUREMENTS AND FIT OF ALL ITEMS.  
08 ALL COLD-FORMED STEEL EXPOSED OR SEMI-EXPOSED TO CONCRETE, MASONRY OR STUCCO FINISH TO BE GALVANIZED (G-90)  
09 A MINIMUM OF (2) #10 SCREWS TO BE USED TO ATTACH MEMBERS TO ADJOINING FRAMING LINES UNLESS NOTED OTHERWISE.  
10 WELDS SHALL BE MADE ACCORDING TO REQUIREMENTS OF THE AMERICAN WELDING SOCIETY. WELDERS SHALL BE CERTIFIED FOR THIS PROJECT AS QUALIFIED STRUCTURAL WELDERS ACCORDING TO THE REQUIREMENTS OF THE AMERICAN WELDING SOCIETY.  
11 ALL CONNECTIONS UTILIZING THREAD FORMING OR T-READ CUTTING SCREWS, WITH OR WITHOUT A SELF-DRILLING POINT, SHALL BE INSTALLED AND TIGHTENED IN ACCORDANCE WITH THE MANUFACTURER'S RECOMMENDATIONS.  
12 PROVIDE ALL NECESSARY ERECTION WPS, ANGLES, SEATS, ETC., TO PROPERLY ERECT COLD-FORMED STEEL FRAMING.  
13 FOR THOSE GALVANIZED ITEMS, APPLY A HIGH ZINC DUST CONTENT PAINT FOR RE-GALVANIZING WELDS IN GALVANIZED STEEL, COMPLYING WITH THE MILITARY SPECIFICATION MIL-P-21039 (SHIPS) AFTER ERECTION, NUTS, BOLT HEADS, AND BURS OR ABRASIVE SPOT SHALL BE SPOT PAINTED WITH ABOVE MENTIONED PAINT.  
14 - WOOD & PLASTICS  
01 PROVIDE ALL BLOCKING AND DEADWOOD AS REQUIRED TO GUARANTEE SOLID NAILING OF ALL GYPSUM, ROOFING FASCIA, TRIM, FACING SIDING, CABINETRY, GRAB BARS, ETC. PROVIDE PRESSURE TREATED WOOD FOR ALL EXTERIOR BLOCKING & BLOCKING IN CONTACT W/ METAL OR MASONRY.  
02 - THERMAL & MOISTURE PROTECTION  
01 CONTRACTOR IS RESPONSIBLE FOR PROVIDING ALL FLASHING WEATHER BARRIERS, JOINT COVERS, WEATHER STRIPPING & SEALANTS AS REQUIRED TO MAINTAIN A COMPLETE & WEATHER-TIGHT BUILDING. ALL WORK TO BE IN STRICT COMPLIANCE WITH MANUFACTURER'S WRITTEN RECOMMENDATIONS & APPLICABLE ASTM SPECIFICATIONS. FLASHING SHALL BE INSTALLED AROUND ALL WINDOW AND ROOF OPENINGS. ALL FLASHING TO BE INSTALLED WITH STRICT COMPLIANCE WITH SMACNA ARCHITECTURAL SHEET METAL MANUAL.  
02 GENERAL CONTRACTOR TO CAULK AND SEAL ALL VOIDS AT WINDOWS, DOORS, VACANT AREAS BETWEEN FLOORS, ATTICS AND WALL SILL PLATES.  
03 PROVIDE MINIMUM 20 MIL x 8 INCH SELF-ADHERED FLASHING AT HEAD, JAMB & SILL CONDITIONS FOR ALL OPENINGS. INSTALL AS RECOMMENDED BY MANUFACTURER.  
04 GENERAL CONTRACTOR TO ENSURE ALL AREAS OF PROJECT ARE PROTECTED FROM WATER INTRUSION DURING CONSTRUCTION AND PROTECTED FROM MOLD & MILDEW GROWTH. NO WET MATERIALS SHALL BE COVERED BY INSULATION OR GYPSUM BOARD UNTIL PROPERLY DRIED, COULDED, BUTLER, NICKER OR APPROVED EQUAL.  
05 WRAP TOTAL BUILDING WITH COMMERCIAL BUILDING WRAP.  
06 ALL INSULATION SHALL HAVE RATINGS AS CALLED FOR IN UL FIRE RATED ASSEMBLIES. EXTERIOR WALLS TO RECEIVE R-19; ROOF/ATTIC TO RECEIVE R-38 UNLESS NOTED OTHERWISE.  
07 SEAL ALL EXTERIOR JOINTS AROUND WINDOWS AND DOOR FRAMES, BETWEEN WALL CAVITIES AND WINDOW OR DOOR FRAMES, BETWEEN WALL AND FOUNDATION, BETWEEN WALL AND ROOF, BETWEEN WALL PANELS, AND ALL PENETRATIONS OF UTILITIES THROUGH WALLS AND ROOFS, WHERE JOINTS ARE CONCEALED OR SEMI-CONCEALED, PROVIDE DOUBLE BACKER ROD & SEALANT.  
08 PROVIDE COMPATIBLE SEALANT AT ALL DISSIMILAR MATERIALS (BRICK, STONE, WOOD, STUCCO, ETC.)  
09 ROOFING SHALL BE INSTALLED PER MANUFACTURERS RECOMMENDATIONS.  
10 ALL CAVITY OR CONCEALED SPACES SHALL BE SEALED AND MADE WEATHER-TIGHT (WEATHER STRIPPED).  
11 WATER RESISTANT SHALL NOT BE ALLOWED IN CONCEALED SPACES OUTSIDE OF THE CONDITIONED BUILDING ENVELOPE (INCLUDING BREEZEWAY OR PATIO FLOOR SPACES OR ATTICS); WATER PIPING IN EXTERIOR WALLS SHALL BE LOCATED ON CONDITIONED SIDE OF WALL INSULATION.  
12 PROVIDE CLOSED CELL SPRAY FOAM SEALANT AROUND ALL OPENINGS AND ABOVE TOP PLATES. INSTALL AS RECOMMENDED BY MANUFACTURER.  
13 SEALANT FOR USE IN BUILDING EXPANSION JOINTS: SINGLE COMPONENT, NEUTRAL-CURING SILICONE SEALANT, ASTM C 920, TYPE S, GRADE NS, CLASS 50, FOR USE INT.  
14 SEALANT FOR USE IN USE WHERE ANOTHER TYPE IS NOT SPECIFIED: SINGLE-COMPONENT, NEUTRAL CURING SILICONE SEALANT, ASTM C 920, TYPE S; GRADE NS; CLASS 50, FOR USE INT.  
15 SEALANT FOR EXTERIOR JOINTS: NONSAG, NON-STAINING LATEX PRE-CURLED USE OF POURABLE SEALANT: SINGLE-COMPONENT, NONSAG URETHANE SEALANT, ASTM C 920, TYPE S, GRADE NS, CLASS 25; FOR USE INT.  
16 SEALANT FOR EXTERIOR TRAFFIC-BEARING JOINTS, WHERE SLOPE ALLOWS USE OF POURABLE SEALANT: SINGLE-COMPONENT, POURABLE URETHANE SEALANT, ASTM C 920, TYPE S, GRADE P, CLASS 26; FOR USE INT.  
17 SEALANT FOR USE IN INTERIOR JOINTS IN CERAMIC TILE AND OTHER HARD SURFACES IN KITCHENS AND TOILET ROOMS AND AROUND PLUMBING FIXTURES: SINGLE-COMPONENT, MILDEW-RESISTANT SILICONE SEALANT, ASTM C 920, TYPE S; GRADE NS, CLASS 26; FOR USE INT. FORMULATED WITH SILICONE.  
18 SEALANT FOR INTERIOR USE AT PERIMETERS OF DOOR AND WINDOW FRAMES: ACRYLIC LATEX OR SILICONIZED ACRYLIC LATEX, ASTM C 834, TYPE OF GRADE NF.  
19 ACOUSTICAL SEALANT: NONSAG, PAINTABLE, NON-STAINING LATEX SEALANT COMPLY WITH ASTM C 834 THAT EFFECTIVELY REDUCES AIRBORNE SOUND TRANSMISSION AS DEMONSTRATED BY TEXTING ACCORDING TO ASTM E 90.  
20 COMPATIBILITY: PROVIDE JOINT SEALANTS, JOINT FILLERS, AND OTHER RELATED MATERIALS THAT ARE COMPATIBLE WITH ONE ANOTHER AND WITH JOINT SUBSTRATES UNDER SERVICE AND APPLICATION CONDITIONS.  
21 COLORS OF SEALANT SHALL BE AS SELECTED BY THE OWNER FROM THE STANDARD COLORS NORMALLY AVAILABLE FROM THE SPECIFIED MANUFACTURERS.  
22 COLORS OF CAULKING COMPOUND SHALL BE CUSTOMIZED IF REQUIRED TO MATCH EXISTING MILLWORK.  
31 - OPENINGS  
01 SEE WINDOW & DOOR SCHEDULES ON DRAWINGS FOR DOOR AND WINDOW DESCRIPTIONS.  
02 PROVIDE LEVEL LANDINGS AT EACH SIDE OF ALL DOORS. ALL THRESHOLDS TO BE ADA COMPLIANT AND MORE THAN 1/2" W/ BEVELED TRANSITION. ALL THRESHOLDS SHALL BE SUPPORTED BY FOUNDATION OR BRICK ROWLOCK SILL AND SHALL BE CAULKED AT JAMBS AND UNDERNEATH.  
03 REQUIRED SPECIAL LOCKING SUBMITTAL TO A STATE FIRE MARSHAL FOR DELAYED EGRESS COMPONENTS TO BE PROVIDED BY DOOR HARDWARE INSTALLER. COORDINATE REQUIREMENTS W/ FIRE ALARM INSTALLER IF APPLICABLE.  
04 DOORS SHALL BE MORTISED, REINFORCED AND FUNCTION HOLES PROVIDED AT THE FACTORY IN ACCORDANCE WITH THE HARDWARE SCHEDULE AND TEMPLATES PROVIDED BY THE HARDWARE SUPPLIER. THROUGH BOLT HOLES, ATTACHMENT HOLES, OR DRILLING AND TAPPING FOR SURFACE HARDWARE, SHALL BE DONE BY OTHERS IN THE FIELD.  
05 INSTALL DOORS PER MANUFACTURER'S SPECIFIC SYSTEM IN ACCORDANCE WITH HARDWARE MANUFACTURER'S TEMPLATES AND INSTRUCTIONS.  
06 ALL WOOD DOORS TO BE 5-PLY BIRCH VENEER, BOOKMATCH, TRANSPARENT FINISH SELECTED FROM MFRS STANDARD COLORS AS MANUFACTURED BY MARSHFIELD, US PLYWOOD, GEORGIA PACIFIC OR APPROVED EQUAL.  
07 PROVIDE STEEL DOORS AND FRAMES COMPLYING WITH THE STEEL DOOR AND FRAME ANSIS/D100 (LATEST EDITION). SHEETS ARE TO BE MADE OF COMMERCIAL QUALITY HOT DIPPED ZINC COATED 20 GA. STEEL. THAT COMP. RES WITH ASTM A1024 AND RECO DOOR PRODUCTS, CURRIES COMPANY, FLEMING OR APPROVED EQUAL.  
08 DOORS TO BE COMPLETELY FILLED WITH 2.0 DENSITY RIGID FOAMED-IN-PLACE POLYURETHANE CORE CHEMICALLY BONDED TO ALL INTERIOR SURFACES WITH A MINIMUM INSULATION VALUE OF R9.  
09 ALL GLASS SHALL BEAR THE LABEL OF ITS MANUFACTURER AND SHALL CONFORM IN ALL RESPECTS WITH THE PERTINENT REQUIREMENTS OF FEDERAL SPECIFICATIONS FOR GLASS. GLASS SHALL BE RELATIVELY DISTORTION-FREE WITH ALL DISTORTION WAVES IN THE HORIZONTAL DIRECTION. GLASS FOR INTERIOR DOOR VIEW LIGHTS AND ENTRANCE DOOR VIEW LIGHTS SHALL BE 1/4" POLISHED GLASS. SAFETY GLASS SHALL BE USED WHERE REQUIRED BY CODE, OR WHERE SHOWN ON THE DRAWINGS. ALL EXTERIOR GLAZING TO BE THERMAL INSULATED, LOW-E TEMPERED GLAZING.

**CONSTRUCTION NOTES**

07 PROVIDE STANDARD DUTY (UNLESS NOTED OTHERWISE ON DOOR SCHEDULE), BRUSHED STAINLESS STEEL FINISH (OR COMPATIBLE) COMMERCIAL DOOR HARDWARE. PROVIDE ALL LOCKERS AND LOCKSETS AS REQUIRED FOR APPLICATION. PROVIDE PANIC HARDWARE/EXIT DEVICES AS REQUIRED FOR ALL DOORS INDICATED ALONG EGRESS PATH OR AS EMERGENCY EXIT DOORS (PRE-LIFE SAFETY PLAN). SUBMIT TO ARCHITECT DOOR & HARDWARE SCHEDULE, PRODUCT DATA & SAMPLES FOR COLOR SELECTION, YALE, CORBIN RUSSWIN, SEARGENT OR APPROVED EQUIVALENT.  
09 FINISHES  
01 FINISH BOARD INSTALLATION SHALL BE IN CONFORMANCE WITH GYPSUM ASSOCIATION'S RECOMMENDED PRACTICES FOR THICKNESS, NAILING, TAPING AND STUD SPACING & SHALL CONFORM TO ASTM C-840 (CURRENT EDITION). PROVIDE GYPSUM BOARD RETURN AT ALL WINDOW JAMBS AND HEAD WITH METAL CORNER BEADS. PROVIDE SMOOTH FINISH (NOT TEXTURED). PROVIDE 5/8" GYPSUM BOARD PRODUCTS UNLESS NOTED OTHERWISE. PROVIDE MOISTURE RESISTANT GWB FOR WALLS & CEILING AT EACH RR AND AT WASHROOMS. PROVIDE IMPACT-RESISTANT GYPSUM AT BREAK AREA, WAREHOUSE, STOCK ROOM & SCREENING. NATIONAL GYPSUM, USG, GP OR APPROVED EQUAL.  
02 ALL PAINT TO BE OF MFR'S BEST QUALITY COATINGS. ALLOW UP TO 6 COLORS (TSD). ALL COATINGS APPLIED AS RECOMMENDED BY MFR PER APPLICATION. WHEN SUBSTRATE IS REQUIRED TO RECEIVE COATING, BUT NOT SCHEDULED, PROVIDE COATING RECOMMENDED BY MFR. SHERWIN WILLIAMS (LISTED), PITTSBURGH, BENJAMIN MOORE OR APPROVED EQUAL. EXTERIOR/INTERIOR: ALL SURFACE ENAMEL AT EXTERIOR. SEALED CONCRETE, MBO COATING, EXTERIOR WOOD: WOODSCAPES SEMI-TRANSPARENT STAIN W/ HIGH-SOLID SPAR VARNISH; INTERIOR WALLS: SEMI-GLOSS LATEX, PROMAR200 (EGGSHELL); INTERIOR WOODWORK & TRIM (PAINT): PROMAR200 (EGG-GLOSS); INTERIOR WOOD WORK & TRIM (STAIN): MINWAX WOOD FINISH & POLYURETHANE.  
10 - SPECIALTY EQUIPMENT  
01 PROVIDE UL APPROVED 5# ABC FIRE EXTINGUISHER & CABINETS AS INDICATED ON LIFE SAFETY SHEET. PROVIDE ALL LETTERING & REQUIRED SIGNAGE PRIOR TO COMPLETE WORK.  
02 PROVIDE ADA SIGNAGE AS REQUIRED. PROVIDE 8" x 6" ADA COMPLIANT SIGNAGE AT EACH RESTROOM, AT EACH EXIT DOOR & AT EACH PARKING STALL.  
11 - EQUIPMENT  
01 NOT USED  
12 - FURNISHINGS  
01 NOT USED  
13 - SPECIAL CONSTRUCTION  
01 REFER TO STRUCTURAL DRAWINGS, NOTES & SPECIFICATIONS ON SHEETS PREPARED BY STRUCTURAL ENGINEER. IF ANY NOTES CONTAIN HEREIN CONFLICT, THE MOST STRICT REQUIREMENT TO BE UPHOLD. CONTACT ARCHITECT IMMEDIATELY WITH ANY SUCH CONFLICTS.  
02 PRE-ENGINEERED METAL BUILDING (PEMB) MANUFACTURER TO DESIGN & PROVIDE SEALED SHOP DRAWINGS PREPARED BY A STRUCTURAL ENGINEER LICENSED IN THE STATE OF LOUISIANA. COORDINATE STRUCTURAL REQUIREMENTS W/ POST-TENSIONED FOUNDATION DESIGNER. ALL WORK SHALL BE IN STRICT COMPLIANCE W/ APPLICABLE CODES, MBO, CGO, BUTLER, NICKER OR APPROVED EQUAL.  
03 PEMB TO BE DESIGNED TO WITHSTAND 140 MPH WIND SPEED, EXPOSURE CATEGORY B, #1-10.  
04 PEMB TO PROVIDE STANDING SEAM, 26 GA. (BOTH SIDES) STRIATED METAL ROOF PANEL. HIGHEST QUALITY KYMARHYLAR FINISH OF COLOR SELECTED BY OWNER. INTERIOR FINISH TO BE PROVIDED BY OWNER. PROVIDE ALL FLASHING, CLIPS, TRIM, ACCESSORIES, SEALANTS & FASTENERS AS REQUIRED FOR COMPLETE INSTALLATION.  
05 PROVIDE CUTTERS & DOWNSPOUTS FOR ALL DIVISION 13 ROOFS INSTALLED. CALCULATE REQUIRED SIZES BASED ON 100 YEAR STORM PER SMACNA.  
06 REFER TO DIV. 13 ROOF PANEL BY PEMB.  
22 - PLUMBING  
01 CONTRACTOR TO FIELD VERIFY AS NECESSARY THE EXACT ROUTING & SIZES OF ALL PIPING.  
02 ALL WORK, METHODS & INSTALLATIONS TO BE IN ACCORDANCE W/ ALL STATE & LOCAL REGULATIONS AND ALL OTHER AGENCIES & OFFICIALS HAVING JURISDICTION.  
03 CONTRACTOR TO COORDINATE ROUTING OF PIPING IN CEILING SPACES PRIOR TO CONSTRUCTION. COORDINATE FINAL INVERT ELEVATIONS OF BUILDING SANITARY & STORM OUTFALLS AND SITE PIPING W/ EXISTING CONDITIONS/SITE UTILITY CONTRACTOR. MAKE ADJUSTMENTS AS REQUIRED TO ENSURE PROPER CONNECTIONS W/ SITE UTILITIES.  
04 THIS CONTRACTOR TO COORDINATE ROUTING OF PIPING BELOW SLAB W/ PLUMBING & ELECTRICAL CONDUIT. SHOULD A CONFLICT OCCUR, THIS CONTRACTOR TO NOTIFY THE DESIGNER PRIOR TO INSTALLING AN ALTERNATE PIPING PLAN.  
05 ALL FLOOR DRAINS TO BE INSTALLED W/ TRAP SEALS & PRIMERS.  
26 - ELECTRICAL  
01 REFER TO ELECTRICAL DRAWINGS, NOTES & SPECIFICATIONS. IF ANY NOTES CONTAIN HEREIN CONFLICT, THE MOST STRICT REQUIREMENT TO BE UPHOLD. CONTACT DESIGNER IMMEDIATELY WITH ANY SUCH CONFLICTS.  
31 - EARTH WORK  
01 REFER TO CIVIL DRAWINGS, NOTES & SPECIFICATIONS ON SHEETS PREPARED BY CIVIL ENGINEER. IF ANY NOTES CONTAIN HEREIN CONFLICT, THE MOST STRICT REQUIREMENT TO BE UPHOLD. CONTACT DESIGNER IMMEDIATELY WITH ANY SUCH CONFLICTS.  
02 VERIFY LOCATION OF ALL OVERHEAD AND UNDERGROUND UTILITIES AND SUBSURFACE DRAINAGE PRIOR TO THE START OF WORK.  
THE BUILDING SLAB SHALL HAVE A MINIMUM OF SIX INCHES OF EXPOSED AFTER INSTALLATION OF LANDSCAPING MATERIALS. THE FINAL GRADE SHOULD SLOPE AWAY FROM THE BUILDING TO AVOID WATER PONDING AT THE BUILDING SLAB.  
03 ALL FOREIGN MATERIALS SHALL BE REMOVED FROM WITHIN 6 INCHES OF FINISHED GRADE.  
04 SOIL FILL INSIDE BUILDING LINES AND UNDER SLABS, UNLESS OTHERWISE SPECIFIED HEREIN AFTER, SHALL BE READY COMPACTIBLE SOIL, PLACED ROLLED AND COMPACTED IN 6 INCH LIFTS TO A MINIMUM OF 95% STANDARD PROCTOR UNLESS NOTED OTHERWISE.  
05 REFER TO POURING BUILDING SLABS. ALL SOIL EXTENDING TO 3' OUTSIDE BUILDING PERIMETER (INCLUDING ALL SURFACES AND FOOTINGS) SHALL BE CHEMICALLY TREATED FOR TERMITES (SEE SPECIFICATIONS).  
06 SOIL FILL OUTSIDE BUILDING SLABS: UPON COMPLETION OF THE WORK, FILL & GRADE SITE AREA WITH TOPSOIL (READY FOR PLANTING) AROUND BUILDING AND WALKS (1" BELOW SIDEWALK). MAXIMUM SLOPE (1:6) AROUND BUILDING SLABS OR AS INDICATED OTHERWISE.



SITE LOCATION

**BUILDING CODES:**

ALL WORK SHALL BE IN COMPLIANCE WITH:

2021 INTERNATIONAL BUILDING CODE (IBC) (EXCLUDE CHAPTERS 1, 11, 27)  
2021 INTERNATIONAL EXISTING BUILDING CODE (IEBC), (EXCLUDE CHAPTER 1)  
2021 INTERNATIONAL MECHANICAL CODE (IMC)  
2015 NFPA 101 (LIFE SAFETY CODE), EXCLUDING CHAPTER 5  
2021 INTERNATIONAL FUEL GAS CODE (IFGC)  
2020 NATIONAL ELECTRIC CODE (NEC)  
2021 INTERNATIONAL PLUMBING CODE  
2015 ADA-ABA ACCESSIBILITY GUIDELINES

THESE CODES SHALL BE CONSIDERED AS PART OF THESE DOCUMENTS.

**GENERAL NOTES:**

- WORK SHALL CONFORM TO ADAAG. CONSULT WITH ARCHITECT IF MOUNTING HEIGHTS OR CLEARANCES ARE IN DOUBT.  
THRESHOLDS SHALL NOT BE HIGHER THAN 1/2" AND BEVELED OVER 1/4". DOOR HANDLES SHALL BE LEVER SETS (SCHLAGE A SERIES OR EQUAL). EGRESS LOCKS SHALL BE SINGLE ACTION RELEASE REQUIRING NO SPECIAL KNOWLEDGE, KEY, OR EFFORT FOR EGRESS. LANDING OUTSIDE OF DOORS SHALL ALIGN WITH FINISH FLOOR AT THRESHOLD AND SHALL SLOPE AWAY FROM BUILDING AT A SLOPE NOT TO EXCEED 1:50.
- GROUND AND FLOOR SURFACES SHALL BE SLIP RESISTANT UNDER ALL WEATHER CONDITIONS. CONCRETE SHALL HAVE A BROOM FINISH PERPENDICULAR TO THE SLOPE.
- TOILET & BATHING ROOM FLOORS SHALL HAVE A SMOOTH, HARD, NONABSORBANT SURFACE THAT EXTENDS UPWARD FROM THE WALLS AT LEAST 6" PER IBC 1210.1. ANY WALLS WITHIN 2 FEET OF URINALS & WATER CLOSETS SHALL HAVE A SMOOTH, HARD, NONABSORBANT SURFACE TO A HEIGHT OF 4 FEET ABOVE THE FLOOR, & EXCEPT FOR STRUCTURAL ELEMENTS, THE MATERIALS USED IN SUCH WALLS SHALL BE OF A TYPE THAT IS NOT ADVERSELY AFFECTED BY MOISTURE PER 19C 1210.2. (TYPICAL AT ALL BATHROOMS).
- INSULATION AND INSULATION ASSEMBLIES SHALL MEET THE REQUIREMENTS OF SECTION 720, INTERNATIONAL BUILDING CODE, 2015 EDITION.
- CONCEALED AND EXPOSED INSULATION SHALL HAVE A FLAME SPREAD OF 0-25 AND A SMOKE DEVELOPED OF 0-450 IN ACCORDANCE WITH IBC 718.
- CELLULOSE FIBER THERMAL INSULATION SHALL MEET THE REQUIREMENTS OF PARAGRAPH IBC 718.
- INTERIOR WALLS AND CEILINGS SHALL HAVE A FLAME SPREAD OF 0-25 AND A SMOKE DEVELOPMENT RATINGS OF 0-450.
- BUILDINGS AND STRUCTURES CONSTRUCTED IN WHOLE AND IN PART IN FLOOD HAZARD AREAS SHALL BE DESIGNED IN ACCORDANCE WITH THE PROVISIONS CONTAINED IN IBC.  
TRAVEL DISTANCE TO A FIRE EXTINGUISHER SHALL NOT EXCEED 75' FOR CLASS A, C AND D FIRES.

**IBC 2021 DATA**

**OCCUPANCY CLASSIFICATION:**  
BUSINESS GROUP B

**SQUARE FOOTAGES**  
CONDITIONED SPACE = 2804 S.F.  
FRONT PORCH = 271 S.F.  
REAR PORCH = 49 S.F.  
TOTAL AREA U.S. = 3124 S.F.

**OCCUPANT LOAD**  
BUSINESS GROUP B 3024 / 150 GROSS = 20.16  
TOTAL OCCUPANTS = 21

**CONSTRUCTION CLASSIFICATION: (SEC 601)**  
TYPE VB / SINGLE STORY

**FIRE RESISTANCE RATING REQUIREMENTS FOR BLDG. ELEMENTS: (TBL 601)**

STRUCTURAL FRAME	= 0 HR
BEARING WALLS	= 0 HR
INTERIOR AND EXTERIOR	= 0 HR
NON-BEARING WALLS	= 0 HR
FLOOR CONSTRUCTION	= 0 HR
ROOF CONSTRUCTION	= 0 HR

**FIRE RESISTANCE RATING REQUIREMENTS FOR EXTERIOR WALLS:**

EXTERIOR WALLS WITH 5' < X < 10' = FIRE SEPARATION DISTANCE = 0 HR.

**FIRE ALARM SYSTEM REQUIREMENTS: (SEC 907)**

THIS BLDG. DOES NOT REQUIRE A FIRE ALARM SYSTEM IN ACCORDANCE WITH SEC 907

**GRAVITY LOAD DATA (IBC SEC. 1607):**

ROOF LIVE LOAD	20 LBS PER SQ. FT.
ROOF (GROUND) SNOW LOAD	5 LBS PER SQ. FT.
UNINHABITED ATTIC W/O STORAGE LIVE LOAD	10 LBS PER SQ. FT.
OFFICE FLOOR LIVE LOAD	50 LBS PER SQ. FT.
LOBBIES & FIRST FLOOR CORRIDORS LIVE LOAD	100 LBS PER SQ. FT.

**CODES AND DESIGN SPECIFICATIONS**  
BUILDING CODE: INTERNATIONAL BUILDING CODE (IBC) 2021  
NATIONAL DESIGN SPECIFICATION FOR WOOD FRAMED CONSTRUCTION 2018 ASCE 7-16

**DESIGN LOADS**

- ROOF DESIGN LOADS
- CEILING COLLATERAL DEAD LOAD = 10 PSF
- CEILING LIVE LOAD = 20 PSF
- ROOF COLLATERAL DEAD LOAD = 10 PSF
- ROOF LIVE LOAD = 20 PSF
- WIND LOAD CRITERIA
- ULTIMATE WIND SPEED = 140 MPH
- NOMINAL WIND SPEED = 118 MPH
- OCCUPANCY CATEGORY = II
- EXPOSURE CATEGORY = B
- INTERNAL PRESSURE COEFFICIENT = +/- 0.18

TOTAL SHEAR PERPENDICULAR TO LENGTH = 81 KIP (ULTIMATE)  
TOTAL SHEAR PERPENDICULAR TO WIDTH = 22 KIP (ULTIMATE)

**PROJECT DESCRIPTION:**

NEW CONSTRUCTION OF A SINGLE STORY WOOD FRAME BUSINESS GROUP "B"

**DRAWING INDEX:**

SHEET #	DESCRIPTION
LS1	LANDSCAPE PLAN
A1	SITE PLAN
A2	EXTERIOR ELEVATIONS & ROOF PLAN
A3	FLOOR PLAN
A4	INTERIOR ELEVATIONS
A-E1	POWER & DATA DIAGRAM
S1	FLOOR PLAN STRUCTURAL
S2	FRAMING SECTIONS A & B
S3	FRAMING SECTIONS C & D
S4	CEILING JOIST PLAN
S5	FRAMING & CONNECTION DETAILS
S6	FOUNDATION PLAN
P101	PLUMBING PLAN
M101	MECHANICAL PLAN
E101	LIGHTING PLAN
E102	POWER PLAN
E105	PANELS & RISER DIAGRAMS
H1	HANDICAP REQUIREMENTS
H2	HANDICAP REQUIREMENTS

NOTE:  
 ALTHOUGH EVERY EFFORT  
 HAS BEEN MADE IN  
 PREPARING THESE  
 DRAWINGS, THE  
 ARCHITECT ASSUMES NO  
 LIABILITY FOR ERRORS OR  
 OMISSIONS. THE USER  
 SHALL BE RESPONSIBLE  
 FOR CHECKING THE PLANS  
 FOR ACCURACY AND FOR  
 ERRORS BEFORE  
 CONSTRUCTION BEGINS.

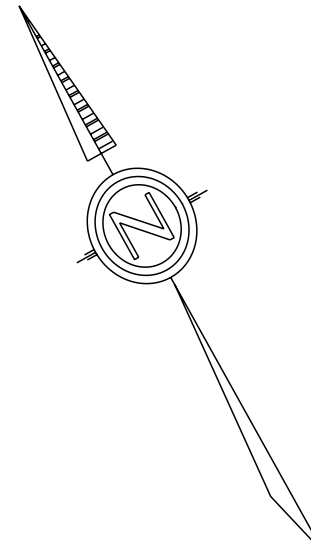
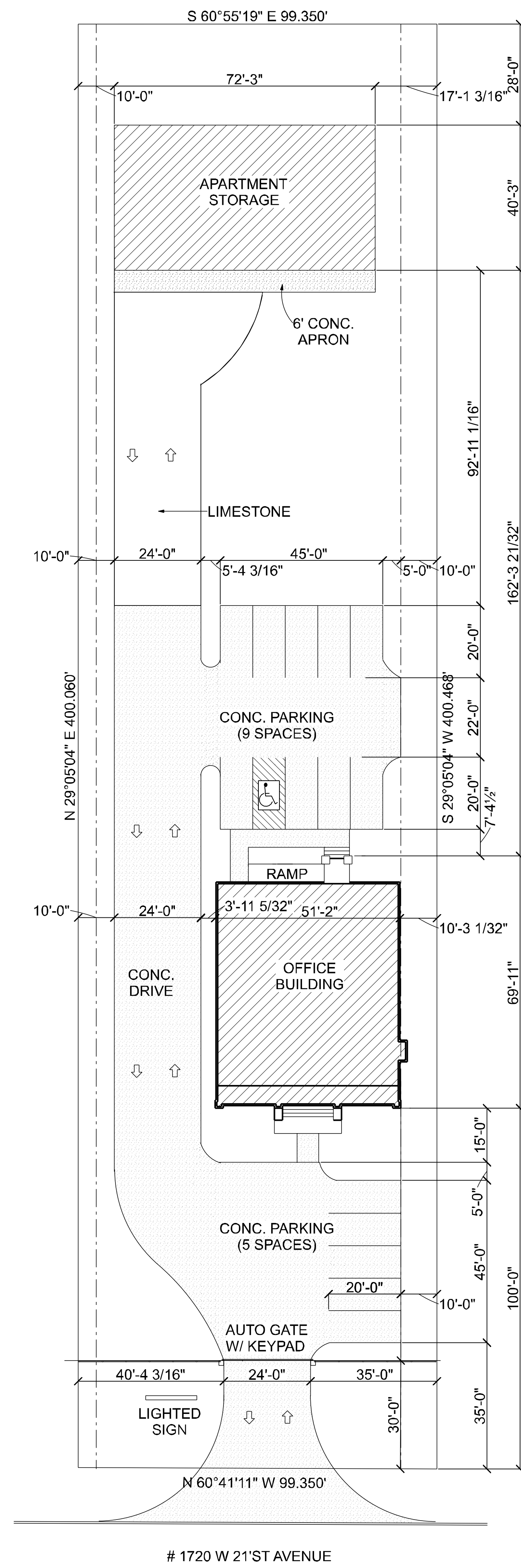


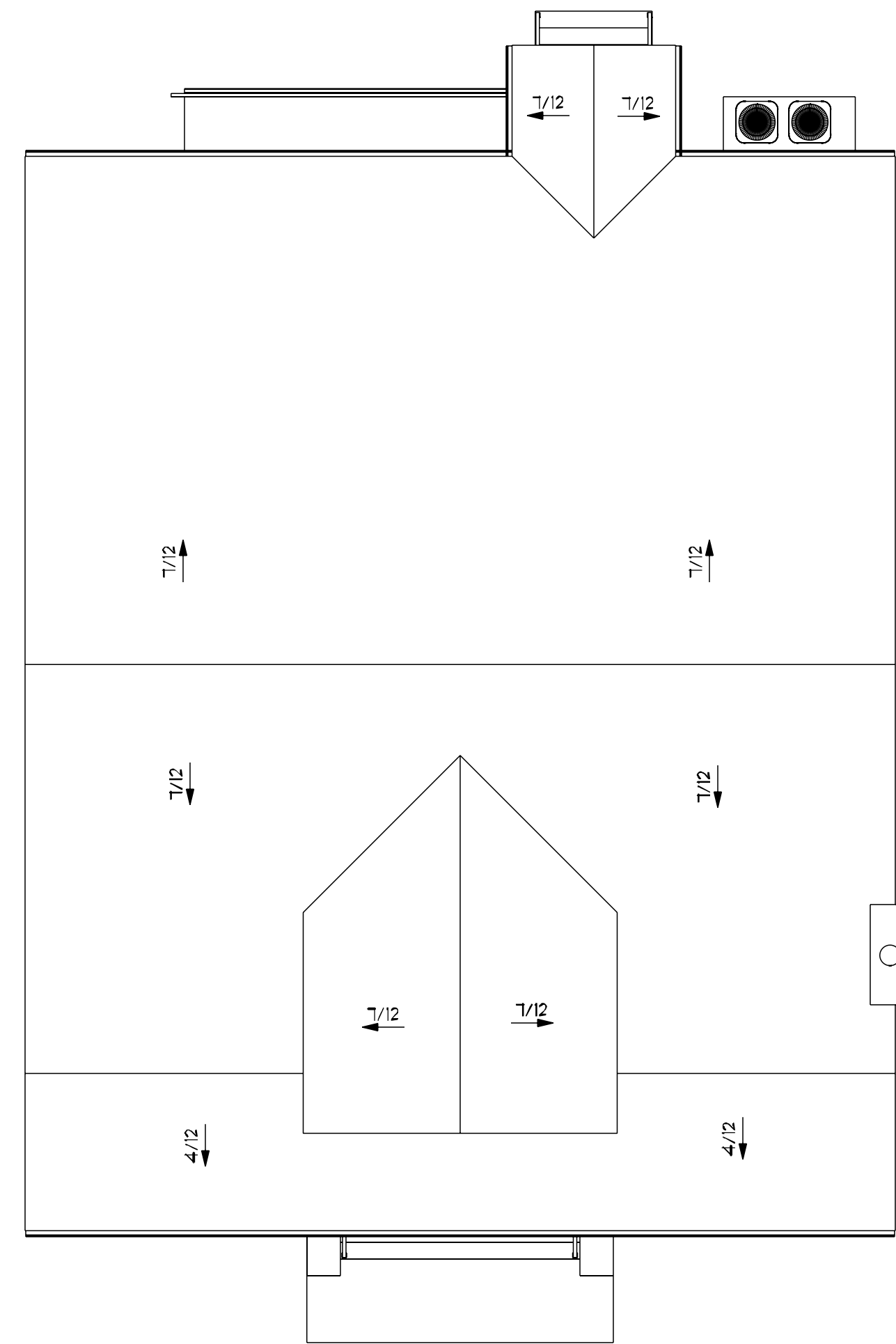
PROJECT DESIGNERS:  
**CLARKE'S DESIGN SERVICE, LLC.**  
 1537 THIRD STREET SLIDELL, LA 70458  
 WWW.CLARKEDESIGN.COM (985) 641-0531

PROJECT:  
 RAWLIN CARTER  
 PRUDENTIAL FINANCIAL ADVISOR  
 1720 W 21ST AVENUE  
 CITY OF COVINGTON, LA.

CODE:  
 7408  
 DATE:  
 03-25-26

DESCRIPTION:  
 SITE  
 PLAN  
 SHEET:  
 A1





**ROOF PLAN**  
SCALE = 1/8"=1'-0"

**UNDERLAYMENT:**  
SHALL CONSIST OF (2) LAYERS, APPLY A 1" STRIP OF UNDERLAYMENT FELT PARALLEL TO & STARTING @ THE EAVES, STARTING @ THE EAVE, APPLY 36" WIDE SHEETS OF UNDERLAYMENT, OVERLAPPING SUCCESSIVE SHEETS 18". DISTORTIONS IN THE UNDERLAYMENT SHALL NOT INTERFERE W/ THE ABILITY OF THE SHINGLES TO SEAL. END LAPS SHALL BE 4" & SHALL BE OFFSET BY 6 FT.

**EXCEPTION - AS AN ALTERNATIVE, SELF-ADHERING POLYMER-MODIFIED BITUMEN UNDERLAYMENT BEARING A LABEL INDICATING COMPLIANCE W/ ASTM D1970.**

**UNDERLAYMENT ATTACHMENT:**  
SHALL BE ATTACHED W/ CORROSION-RESISTANT FASTENERS IN A GRID PATTERN OF 12" BTW, SIDE LAPS W/ A 6" SPACING @ SIDE & END LAPS SHALL BE ATTACHED USING ANNULAR RING OR DEFORMED SHANK NAILS W/ 1" DIAM. METAL OR PLASTIC CAPS. METAL CAPS SHALL BE MIN. 32-GAUGE THICK POWER-DRIVEN METAL CAPS SHALL BE MIN. .010 THICK, MIN THICKNESS TO THE OUTSIDE EDGE OF PLASTIC CAPS SHALL BE .035". THE CAP NAIL SHANK MN. .083", NAIL LENGTH LONG ENOUGH TO PENETRATE THROUGH THE ROOF SHEATHING OR NOT LESS THAN 3/4" INTO THE ROOF SHEATHING.

**ICE BARRIERS:**  
SHALL CONSIST OF (2) LAYERS OF UNDERLAYMENT CEMENTED TOGETHER, OR A SELF-ADHERING POLYMER-MODIFIED BITUMEN SHEET SHALL BE USED IN PLACE OF & EXTEND FROM THE LOWEST EDGES OF ALL ROOF SURFACES A MIN. OF 24" INSIDE THE EXTERIOR WALL LINE OF THE BUILDING, ON ROOFS W/ 8/12 OR GREATER, THE ICE BARRIER SHALL ALSO BE APPLIED MIN. 24" MEASURED ALONG THE ROOF SLOPE FROM THE EAVE EDGE OF THE BUILDING.

**SHINGLE CLASSIFICATION:**  
ASPHALT SHINGLES SHALL BE ASTM D7158 CLASSIFICATION G OR H, ASTM D3181 CLASSIFICATION F.

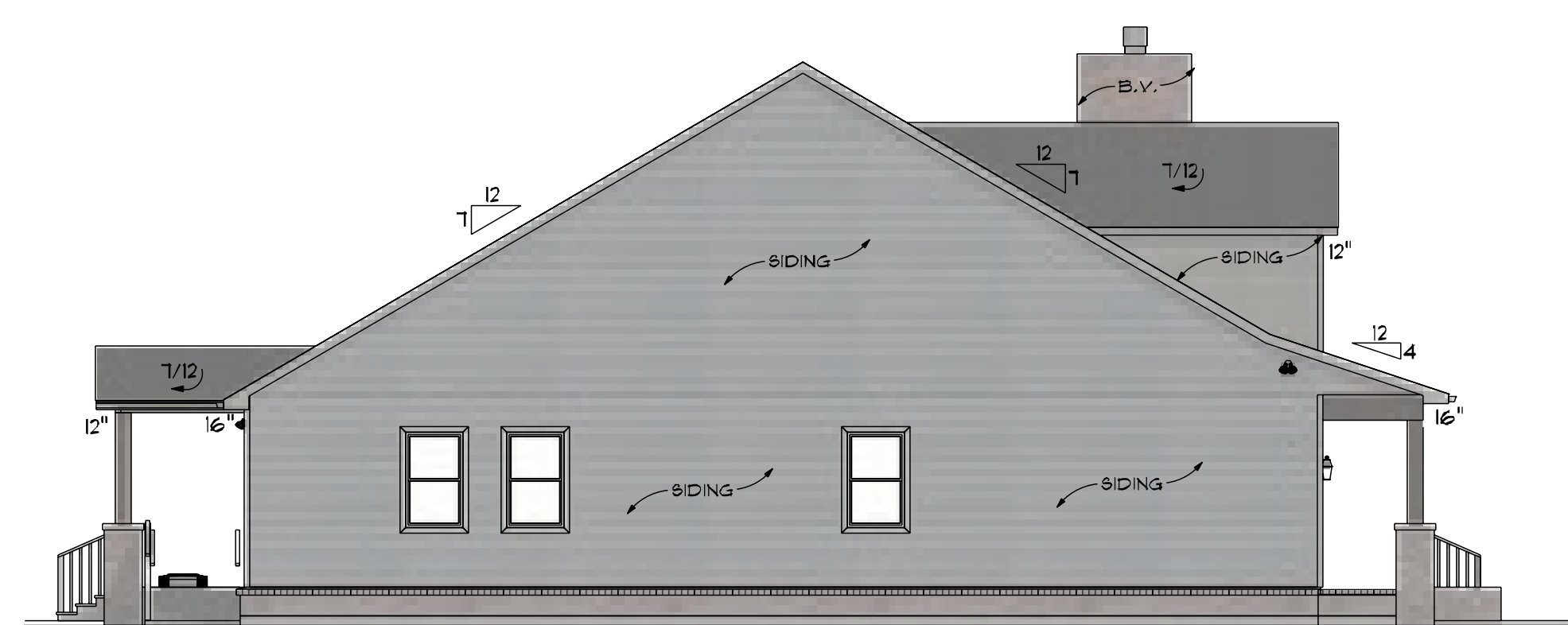
**FASTENERS:**  
SHALL BE GALVANIZED STEEL, STAINLESS STEEL, ALUMINUM OR COPPER ROOFING NAILS, MIN. 12-GAUGE SHANK W/ A MIN. 3/8" DIAMETER HEAD, (ASTM F1997), OF A LENGTH TO PENETRATE THROUGH THE ROOFING MATERIALS & NOT LESS THAN 3/4" INTO or THROUGH THE ROOF SHEATHING.

**ATTACHMENT:**  
SHALL HAVE A MIN. NUMBER OF FASTENERS REQUIRED BY THE MANUF. BUT NOT LESS THAN (4) FASTENERS PER STRIP SHINGLE or (2) FASTENERS PER INDIVIDUAL SHINGLE. ROOF SLOPE MORE THAN 2/12 SEE MANUF. REQUIREMENTS.

**TYPICAL ASPHALT ROOFING**



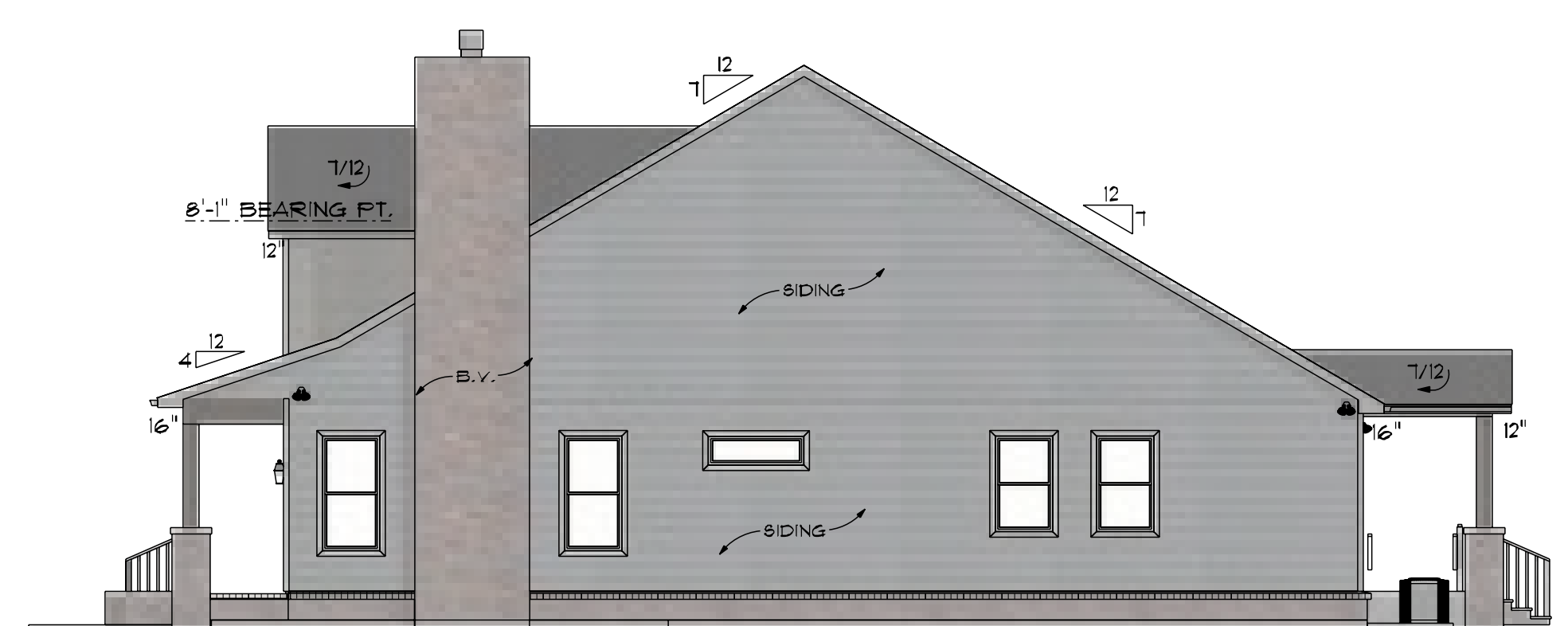
**FRONT ELEVATION**  
SCALE = 1/4"=1'-0"



**LEFT ELEVATION**  
SCALE = 1/8"=1'-0"



**REAR ELEVATION**  
SCALE = 1/8"=1'-0"



**RIGHT ELEVATION**  
SCALE = 1/8"=1'-0"



**NOTE:**  
ALTHOUGH EVERY EFFORT HAS BEEN MADE IN THESE DRAWINGS, THE ARCHITECT ASSUMES NO LIABILITY FOR CHECKING THE PLANS FOR ERRORS BEFORE CONSTRUCTION BEGINS.

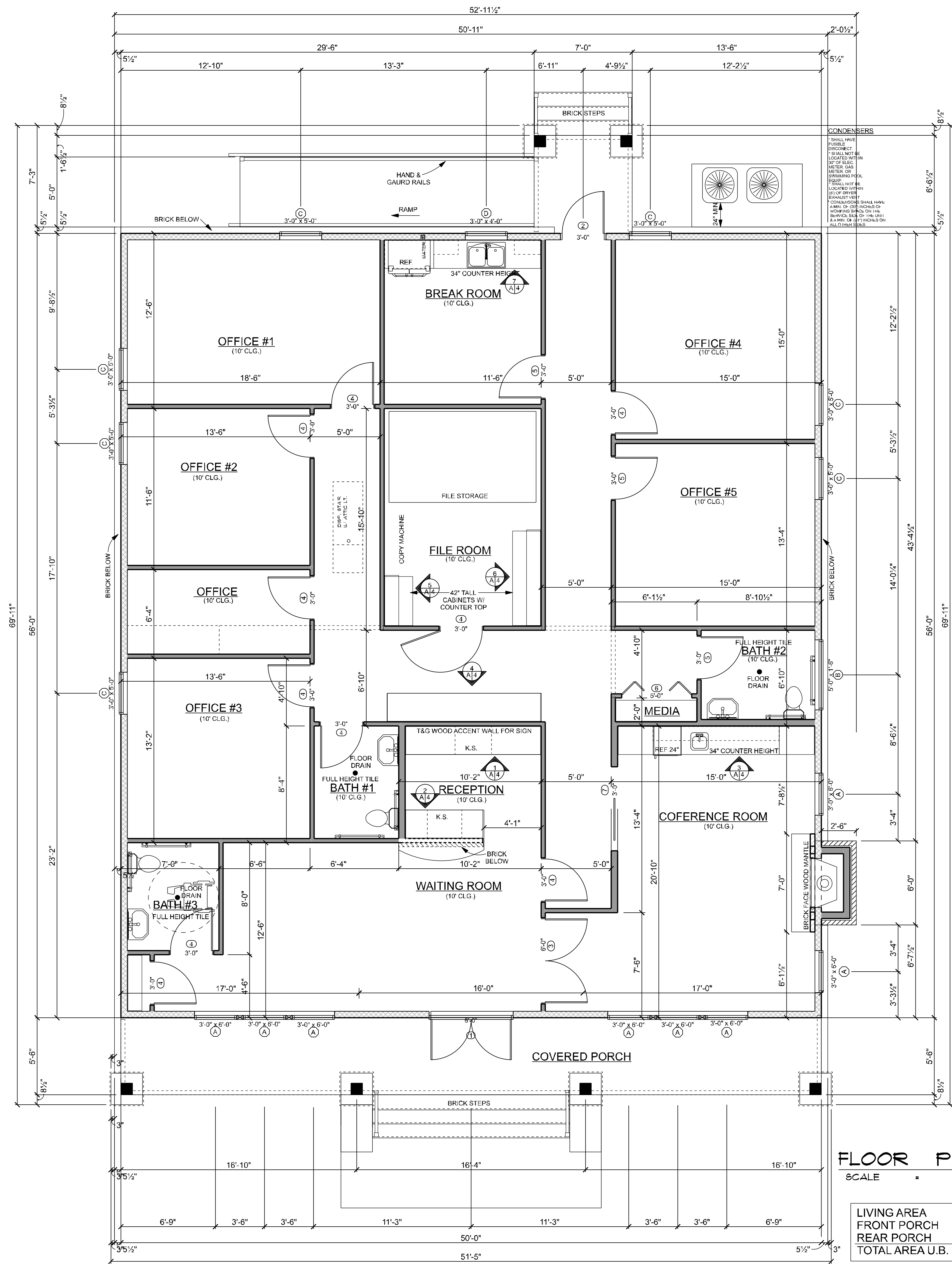


**PROJECT DESIGNERS:**  
**CLARKE'S DESIGN SERVICE, LLC.**  
1537 THIRD STREET SLIDELL, LA 70458  
WWW.CLARKEDESIGN.COM (985) 641-0531

**PROJECT:**  
RAWLIN CARTER  
PRUDENTIAL FINANCIAL ADVISOR  
1720 W 21ST AVENUE  
CITY OF COVINGTON, LA.

**CODE:**  
7408  
**DATE:**  
03-25-26

**DESCRIPTION:**  
EXTERIOR  
ELEVATIONS &  
ROOF PLAN  
**SHEET:**  
A2



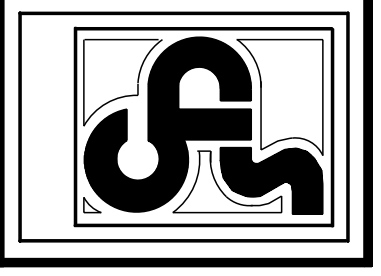
**FLOOR PLAN**  
SCALE 1/4"=1'-0"

LIVING AREA	=	2804
FRONT PORCH	=	271
REAR PORCH	=	49
TOTAL AREA U.B.	=	3124

NOTE:  
ALTHOUGH EVERY EFFORT  
HAS BEEN MADE IN  
PREPARING THESE  
DRAWINGS, THE  
DESIGNER SHALL NOT BE  
ULTIMATELY RESPONSIBLE  
FOR CHECKING THE PLANS  
FOR CONSTRUCTION OR  
CONSTRUCTION BEGINS.



PROJECT DESIGNERS:  
**CLARKE'S DESIGN SERVICE, LLC.**  
1537 THIRD STREET SLIDELL, LA 70458  
WWW.CLARKEDESIGN.COM (985) 641-0531



PROJECT:  
RAWLIN CARTER  
PRUDENTIAL FINANCIAL ADVISOR  
1720 W 21ST AVENUE  
CITY OF COVINGTON, LA.

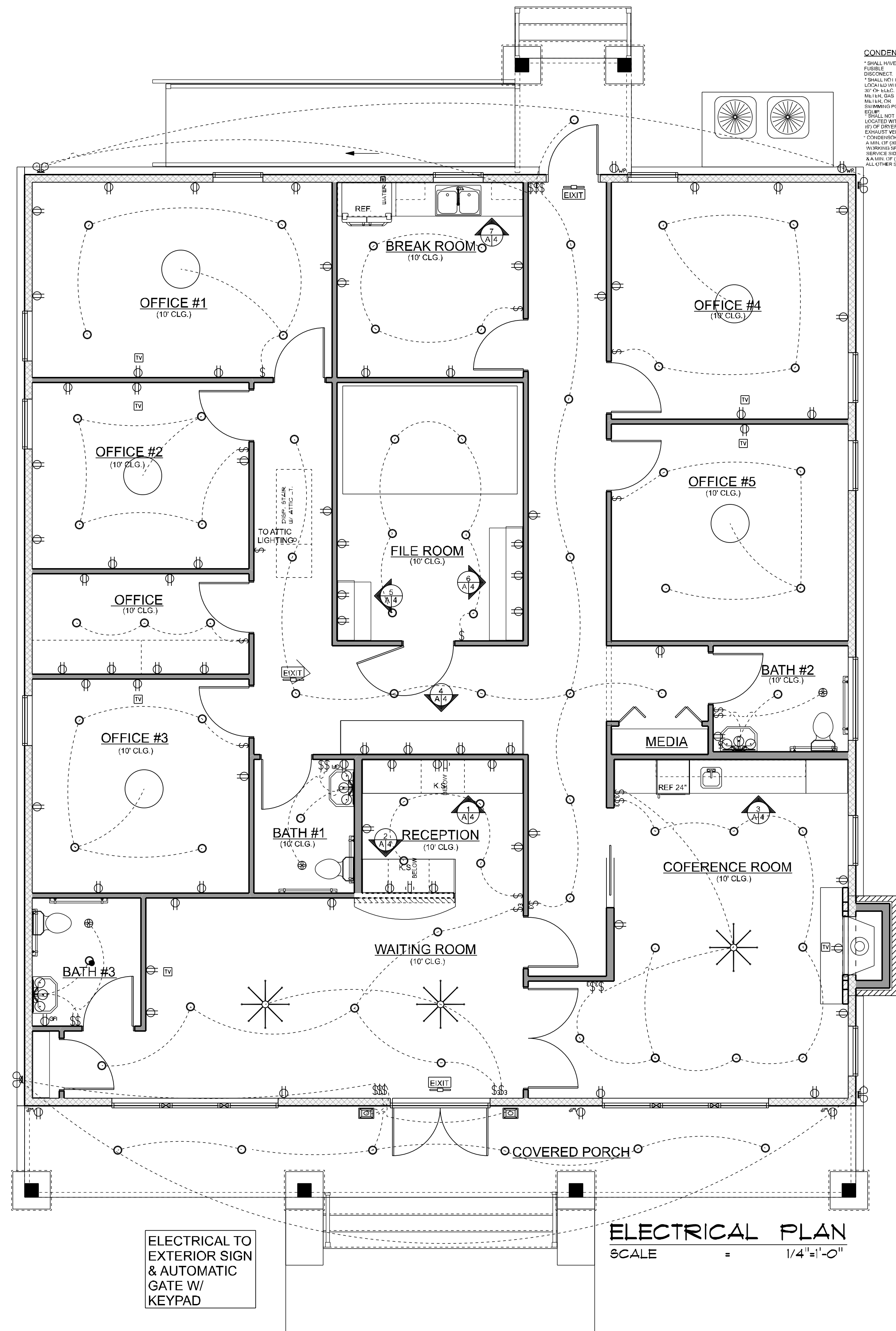
CODE:  
7408  
DATE:  
03-25-26

DESCRIPTION:  
FLOOR PLAN  
SHEET:  
A3

# ELECTRICAL SPECIFICATIONS

- GENERAL**
- VERIFY ALL DIMENSIONS AT THE JOB SITE AND FROM THE ARCHITECTURAL PLANS.
  - UNLESS OTHERWISE NOTED, CONTRACTOR AND SUBCONTRACTOR SHALL PAY FOR ALL PERMITS AND CHARGES REQUIRED AND SHALL COMPLY WITH ALL GOVERNING CODES AND ORDINANCES.
  - VISITING THE SITE: EACH BIDDER SHALL VISIT THE SITE OF THE PROPOSED WORK AND SHALL FULLY INFORM HIMSELF REGARDING THE FACILITIES. NO ADDITIONAL COMPENSATION WILL BE ALLOWED FOR WORK OR MATERIAL OMITTED FROM THE BIDDER'S CONTRACT PROPOSAL DUE TO HIS FAILURE TO SO INFORM HIMSELF BY SUCH INVESTIGATION.
  - ALL CHANNING AND PATCHING OF ROOF, FLOOR, CEILING AND WALLS SHALL BE GENERAL CONTRACTOR.
  - FURNISH AND INSTALL A COMPLETE ELECTRICAL SYSTEM AS INDICATED ON PLANS. ELECTRICAL CONTRACTOR TO MAKE ALL FINAL CONNECTIONS TO ALL EQUIPMENT.
- CONDUIT**
- ALL ELECTRICAL CONDUCTORS SHALL BE INSTALLED IN CONDUIT COMPLYING WITH THE NATIONAL ELECTRICAL CODE. WHERE INSTALLED SUBJECT TO STRESS FROM COLLISION OR IMPACT CONDUIT SHALL BE GALVANIZED RIGID STEEL. WHERE RIGID STEEL CONDUIT IS NOT REQUIRED, CONDUCTORS SHALL BE INSTALLED IN ELECTRICAL METALLIC TUBING (EMT) WITH ELECTRO-GALVANIZING OUTSIDE AND ENAMEL INSIDE.
  - LIQUID-TIGHT FLEXIBLE METAL CONDUIT SHALL BE USED AT ALL MOTOR CONNECTIONS, OR WHERE MOVEMENT/VIBRATION IS A CONCERN.
  - UNLESS NOTED OTHERWISE FLEXIBLE METAL CONDUIT MAY BE USED ONLY FOR CONNECTION TO LIGHTING FIXTURES. IN LENGTHS NOT TO EXCEED (6) FEET. LIGHT FIXTURE WHIPS MAY BE SUPPORTED FROM THE CEILING SUSPENSION SYSTEM WITH "CADDY" CUPS. THEY SHALL NOT REST ON CEILING GRID OR TILE.
  - MC (METAL CLAD) CABLE IS PERMITTED AND SHALL CONFORM TO THE REQUIREMENTS OF NEC 330 METAL CLAD CABLE TYPE MC, AND INSTALLED IN LOCATIONS APPROVED BY LOCAL AUTHORITY HAVING JURISDICTION.
  - MINIMUM CONDUIT SIZE SHALL BE 3/4 INCH. MINIMUM SIZE FOR FLEXIBLE METAL CONDUIT SHALL BE 3/4 INCH.
  - CONDUIT/CONDUCTOR FILL SHALL CONFIRM TO NATIONAL ELECTRICAL CODE, LATEST EDITION.
  - CARLON PVC TYPE SCH. 40 HEAVY WALL CONDUIT WITH GROUND WIRE MAY BE USED BELOW FLOOR SLAB OR UNDERGROUND IN LIEU OF RIGID, THREADED, GALVANIZED CONDUIT. PVC SCH. 40 CONDUIT SHALL NOT BE RUN IN OR ABOVE FLOOR SLAB, OR IN TILT WALL PANELS. PVC CONDUIT SHALL TERMINATE BELOW FLOOR SLAB WITH RIGID, THREADED METAL CONDUIT ADAPTER. CONDUIT ABOVE SLAB SHALL BE METAL.
  - A GROUND CONDUCTOR SHALL BE SUPPLIED IN NONMETALLIC CONDUIT OR EMT UTILIZING SET SCREW TYPE CONNECTORS. THE GROUND CONDUCTOR SHALL BE BARE, STRANDED, ANNEALED COPPER.
  - CONDUIT TO BE SUPPORTED FROM JOIST PROVIDED HANGERS, SUPPORTS AND FASTENINGS AS REQUIRED BY NATIONAL ELECTRICAL CODE. DO NOT SUPPORT FROM ROOF DECK.
- ELECTRICAL BOXES & FITTINGS**
- INTERIOR OUTLET BOXES: PROVIDE GALVANIZED STEEL INTERIOR OUTLET WIRING BOXES, OF THE TYPE, SHAPE, AND SIZE, INCLUDING DEPTH OF BOX, TO SUIT RESPECTIVE LOCATIONS AND INSTALLATION. CONSTRUCT WITH STAMPED KNOCKOUTS IN BACK AND SIDES. PROVIDE GANG BOXES WHERE DEVICES ARE SHOWN GROUPED.
  - INTERIOR OUTLET BOX ACCESSORIES: OUTLET BOX ACCESSORIES AS FOR INSTALLATION, INCLUDING COVERS OR WALL DEVICE PLATES, MOUNTING BRACKETS, WAIRBOARD HANGERS, EXTENSION RINGS, PLASTER RINGS FOR BOXES IN PLASTER CONSTRUCTION, FUTURE STUDS, CABLE CLAMPS AND METAL STRAPS FOR SUPPORTING OUTLET BOXES. ACCESSORIES SHALL BE COMPATIBLE WITH OUTLET BOXES. USED AND MEET REQUIREMENTS OF INDIVIDUAL WIRING.
- INSTALLATION OF BOXES & FITTINGS**
- INSTALL ELECTRICAL BOXES AND FITTINGS AS SHOWN AND AS REQUIRED, IN COMPLIANCE WITH NEC REQUIREMENTS, IN ACCORDANCE WITH THE MANUFACTURER'S WRITTEN INSTRUCTIONS, IN ACCORDANCE WITH INDUSTRY PRACTICES.
  - JUNCTION BOXES ABOVE 2-FOOT X 2-FOOT GRID CEILING SHALL BE MOUNTED WITHIN 18-INCHES OF CEILING GRID. JUNCTION BOXES ABOVE 2-FOOT X 4-FOOT GRID CEILING SHALL BE MOUNTED WITHIN 30-INCHES OF CEILING GRID. ALL JUNCTION BOX OR PULL BOX OPENINGS SHALL BE SIDE OR BOTTOM ACCESSIBLE.
  - USE OUTLET AND SWITCH BOXES FOR JUNCTIONS ON CONCEALED CONDUIT SYSTEMS EXCEPT IN UTILITY AREAS WHERE EXPOSED JUNCTION OR SWITCH BOXES CAN BE USED.
  - UNLESS NOTED OR DIRECTED OTHERWISE AT INSTALLATION, PLACE OUTLET BOXES AS INDICATED ON ARCHITECTURAL ELEVATIONS AND AS REQUIRED BY LOCAL CODES.
  - OUTLETS ABOVE COUNTERS, MOUNT LONG AXIS HORIZONTALLY. REFER TO ARCHITECTURAL ELEVATIONS AND COORDINATE TO CLEAR BACKSPLASH AND MILLWORK.
  - BOXES FOR ANY CONDUIT SYSTEM SHALL NOT BE SECURED TO THE CEILING SYSTEM, HVAC DUCTWORK, OR PIPING SYSTEM.
  - PROVIDE JUNCTION AND PULL BOXES FOR FEEDERS AND BRANCH CIRCUITS WHERE SHOWN AND WHERE REQUIRED BY NEC, REGARDLESS OF WHETHER OR NOT BOXES ARE SHOWN.
  - ALIGN ADJACENT WALL MOUNTED OUTLET BOXES FOR SWITCHES, THERMOSTATS, AND SIMILAR DEVICES.
  - USE FLUSH MOUNTING OUTLET BOX IN FINISHED AREAS.
  - USE ADJUSTABLE STEEL CHANNEL FASTENERS FOR HUNG CEILING OUTLET BOX.
  - DO NOT FASTEN BOXES TO CEILING SUPPORT WIRES.
  - DO NOT MOUNT JUNCTION BOXES ABOVE INACCESSIBLE CEILINGS OR IN INACCESSIBLE SPACES. AT INACCESSIBLE SPACES USE JUNCTION BOX FURNISHED WITH LIGHT FIXTURE OR LIGHT FIXTURE WIRING COMPARTMENT UL LISTED FOR THROUGH WIRING.
- PANEL BOARDS**
- GENERAL: LIGHTING AND APPLIANCE-APPLIANCE PANELBOARDS SHALL BE DEAD-FRONT SAFETY-TYPE EQUIPPED WITH MOLDED CASE CIRCUIT BREAKERS AS SHOWN AND SCHEDULED. POWER DISTRIBUTION PANELBOARDS SHALL BE DEAD-FRONT TYPE EQUIPPED WITH FUSIBLE SWITCHES OR CIRCUIT BREAKERS AS SHOWN AND SCHEDULED. ALL PANELBOARDS SHALL HAVE COPPER BUSSES. LOAD CENTER CONSTRUCTION IS NOT ACCEPTABLE.
  - CIRCUIT BREAKERS: CIRCUIT BREAKERS SHALL BE MOLDED CASE, THERMAL MAGNETIC TYPE EQUIPPED WITH INDIVIDUALLY INSULATED, BRACED, AND PROTECTED CONNECTORS. THE FRONT FACES OF CIRCUIT BREAKERS SHALL BE FLUSH WITH EACH OTHER. TRIPPED INDICATION SHALL BE SHOWN BY THE BREAKER HANDLE TAKING A POSITION BETWEEN ON AND OFF. MAKE PREPARED SPACE PROVISIONS FOR ADDITIONAL BREAKERS SO THAT NO ADDITIONAL CONNECTORS WILL BE REQUIRED TO ADD BREAKERS. CIRCUIT BREAKERS IN LIGHTING AND APPLIANCE PANELBOARDS SHALL HAVE BOLT-IN BREAKERS. TWO AND THREE POLE BREAKERS SHALL HAVE INTERNAL CORNER EXTENSION HANDLE TIES. TIES WILL NOT BE ACCEPTED. CIRCUIT BREAKERS FOR DISTRIBUTION PANELBOARDS SHALL HAVE FWG-ON CIRCUIT BREAKERS.
  - BOARD ENCLOSURES: PROVIDE SHEET STEEL ENCLOSURES, NEMA TYPE 1 (INDOOR NOMINAL THICKNESS, WITH MULTIPLE KNOCKOUTS UNLESS SHOWN OTHERWISE). LIGHTING AND APPLIANCE PANELBOARDS 600 AMPS AND BELOW, PROVIDE PANELBOARD FRONTS WITH PIANO HINGED DOOR IN HINGED TRIM TO BOX, SPRING LOADED DOOR PULLS, AND FLUSH LOCK AND KEY PANELBOARD ENCLOSURES KEYS TO MATCH THE OWNER'S STANDARD KEY SYSTEM. COORDINATE WITH OWNER. EQUIP WITH INTERIOR CIRCUIT DIRECTORY FRAME, CARD, AND CLEAR PLASTIC COVERING FOR LIGHTING AND APPLIANCE PANELBOARDS. ENCLOSURE SHALL BE RECESSED OR SURFACE MOUNTED AS SHOWN. ENCLOSURES SHALL BE FABRICATED BY THE SAME MANUFACTURER AS PANELBOARDS TO BE ENCLOSED. MULTI-SECTION PANELBOARDS SHALL HAVE SAME PHYSICAL DIMENSIONS.
  - DIRECTORY CARP: PROVIDE A TYPED CIRCUIT DIRECTORY CARD(S) UPON COMPLETION OF WORK. DIRECTORY CARD SHALL BE OF SUPER HEAVY-WEIGHT INDEX CARD STOCK, 110 LB. WHITE. DIRECTORY SHALL INCLUDE TYPE OF LOAD (IE RECEPTACLES, LIGHTING, EXHAUST FAN, ETC.) AND LOCATION (IE: ROOM 102, GYMNASIUM, ETC.). ROOM NUMBER SHALL BE IDENTIFIED AS THE ACTUAL GRAPHICS ROOM NUMBER ASSIGNED TO THE SPACE AND NOT THE ROOM NUMBER IDENTIFIED ON THE PLANS. CIRCUITS WITH SHUNT TRIP SHALL BE IDENTIFIED WITH THE CONTROL CIRCUIT OPERATING THE SHUNT TRIP (IE: KITCHEN HOOD NO. 2). SHUNT TRIP BREAKERS WITH COMMON TRIP CIRCUIT SHALL BE GROUPED IN THE PANELBOARD (IE: CIRCUITS 1, 3, 5 AND 7).
- CONDUCTORS**
- ALL CONDUCTORS SHALL BE COPPER. EACH CONDUCTOR SHALL BE CONTINUOUS, WITHOUT WELD, SPLICE, OR JOIST THROUGHOUT ITS LENGTH AND UNIFORM IN CROSS-SECTION. WIRE #6 AWG AND LARGER SHALL HAVE TYPE "THWN" INSULATION. WIRE #8 AWG AND SMALLER SHALL HAVE DUAL-RATED TYPE "THHN/THWN" INSULATION. MINIMUM WIRE SIZE, EXCEPT FOR CONTROL WIRING, SHALL BE #12 AWG.
  - INSULATION SHALL MEET OR EXCEED THE REQUIREMENTS OF UL 83, STANDARD FOR THERMOPLASTIC INSULATED WIRES. INSULATION FOR CONDUCTORS SHALL BE UL TYPE THHN/THWN, 75 C. ALL WIRING INSIDE LIGHTING FIXTURES SHALL BE TEMPERATURE RATED PER NEC.

- WIRING DEVICES**
- RECEPTACLES: COMMERCIAL SPECIFICATION GRADE, 2 POLE, 3 WIRE GROUNDING, WITH GREEN HEXAGONAL EQUIPMENT GROUND SCREW, GROUND TERMINALS AND POLES INTERNALLY CONNECTED TO MOUNTING YOKE, WITH METAL MOUNTING STRAPS, BACK AND SIDE WIRED WITH SCREW TYPE TERMINALS, MOLDED PHENOLIC COMPOUND, NEMA CONFIGURATION INDICATED.
  - WALL SWITCHES: SPECIFICATION GRADE FLUSH TOGGLE SWITCHES, WITH MOUNTING YOKE INSULATED FROM MECHANISM, EQUIPPED WITH PLASTER EARS, SWITCH HANDLE, BACK AND SIDE WIRED SCREW TERMINALS.
  - DO NOT USE FEED THROUGH FEATURE FOR GROUND FAULT INTERRUPTING DEVICES. INSTALL GFI DEVICES AT EACH LOCATION. GFI CIRCUIT BREAKER WILL NOT BE ACCEPTABLE.
  - INTERIOR WALL COVER PLATES: SATIN FINISH TYPE 302 STAINLESS STEEL TYPE 302 STAINLESS STEEL SCREWS SATIN FINISH.
  - INSTALL SWITCHES IN BOXES ON THE STRIKE SIDE OF DOORS AS HUNG. INSTALL A UNIFORM POSITION SO THE SAME DIRECTION WILL OPEN AND CLOSE THE CIRCUIT THROUGHOUT THE PROJECT. WHERE MORE THAN ONE SWITCH IS IN THE SAME LOCATION, INSTALL SWITCHES IN A MULTIGANG BOX WITH A SINGLE COVER PLATE.
  - PROVIDE A PLATE FOR EVERY RECEPTACLE, SWITCH, TELEPHONE OUTLET AND OTHER WIRING DEVICES.
  - MOUNTING HEIGHTS OF ALL WIRING DEVICES SHALL COMPLY WITH CURRENT ACCESSIBILITY STANDARDS AND LOCAL CODES.
  - REFER TO ARCHITECTURAL DRAWING, ELEVATIONS, ETC. FOR EXACT LOCATION OF WIRING DEVICES WHERE INDICATED ON THE ARCHITECTURAL PLANS. COORDINATE LOCATION OF ALL WIRING DEVICES WITH OTHER SPECIALTY ITEMS AND MILLWORK AND AVOID CONFLICTS. COORDINATE WITH ALL TRADES TO AVOID CONFLICTS DURING CONSTRUCTION.
  - PROVIDE WEATHERPROOF NEMA 3R, GFCI, 20A, 125V DUPLEX RECEPTACLES OUTDOORS WHERE INDICATED AND WITHIN 25' OF ALL ELECTRICALLY OPERATED EQUIPMENT MOUNTED OUTDOORS AND ON ROOFS.
  - PROVIDE GFCI, 20A, 125V DUPLEX RECEPTACLES AT ALL RECEPTACLE LOCATIONS INDICATED ON DRAWINGS IN INSTRUCTIONAL FOOD PREPARATION AREAS, KITCHEN AREAS, AND ALL LOCATIONS WHERE RECEPTACLES INDICATED ARE WITHIN SIX FEET OF SINKS OR LAVATORY LOCATIONS.
  - CONNECT WIRING DEVICE GROUNDING TERMINAL TO BRANCH CIRCUIT EQUIPMENT GROUNDING CONDUCTOR.
  - CONNECT WIRING DEVICES BY WRAPPING GROUND CONDUCTOR AROUND SCREW TERMINAL OR WIG. PROVIDE PIGTAIL TO EACH RECEPTACLE AND EACH SWITCH. NEUTRAL AND PHASE CONDUCTORS SHALL BE INSTALLED USING SIDE OR REAR ENTRY LUGS ONLY. DO NOT WRAP CONDUCTORS AROUND SCREW TERMINALS. TIGHTEN ALL SCREWS AND LUGS AS RECOMMENDED BY MANUFACTURER.
  - USE JUMBO SIZE PLATES FOR OUTLET OUTLETS INSTALLED IN MASONRY WALLS.
- CONDUIT FITTINGS**
- ALL CONDUIT FITTINGS SHALL BE STEEL, SET SCREW OR COMPRESSION TYPE, INSULATED THROAT, UL LISTED. FITTINGS SHALL BE AS MANUFACTURED BY APPLINGTON ELECTRIC, OZ GEDNEY CO., ARROW CONDUIT AND FITTINGS CORP., OR EQUAL.
- SAFETY SWITCHES**
- GENERAL: PROVIDE HEAVY DUTY TYPE, DEAD-FRONT, SHEET STEEL ENCLOSED SURFACE MOUNTED SAFETY SWITCHES OF THE TYPE AND SIZE INDICATED. SAFETY SWITCHES SHALL BE RATED FOR THE VOLTAGE OF THE CIRCUIT WHERE THEY ARE INSTALLED. SAFETY SWITCHES USED AS MOTOR DISCONNECTS SHALL BE HORSEPOWER RATED FOR THE MOTOR SERVED.
  - ENCLOSURES: SAFETY SWITCHES INSTALLED AT KITCHEN AND FOOD PREPARATION LOCATIONS HOSE DOWN AREAS, AND IN OTHER CORROSIVE AREAS SHALL BE NEMA 3R.
  - SUPPORTS: PROVIDE ALL SAFETY AND DISCONNECT SWITCHES WITH GALVANIZED ANGLE OR OTHER SUPPORTS WHERE MOUNTING ON WALL OR OTHER RIGID SURFACE IS IMPRACTICAL. SWITCHES SHALL NOT BE SUPPORTED BY CONDUIT ALONE. WHERE SAFETY AND DISCONNECT SWITCHES ARE MOUNTED ON EQUIPMENT SERVED, THE SWITCH SHALL NOT INHIBIT REMOVAL OF SERVICE PANELS OR INTERFERE WITH ACCESS AREAS. PROVIDE MOUNTING HARDWARE THAT WILL ALLOW REMOVAL OF SAFETY AND DISCONNECT SWITCHES. DO NOT UTILIZE DRIVE PIN ANCHORS THROUGH ENCLOSURE.



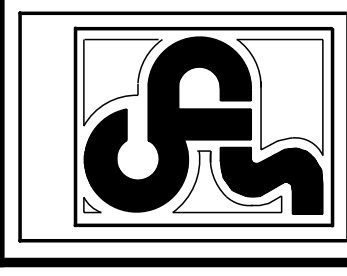
**CONDENSERS**  
 CONDENSERS SHALL HAVE A MINIMUM OF 18 INCHES OF CLEARANCE FROM THE SERVICE SIDE OF THE UNIT AND A MINIMUM OF 24 INCHES FROM ALL OTHER DEVICES.

**NOTE:**  
 ALTHOUGH EVERY EFFORT HAS BEEN MADE IN THESE DRAWINGS, THE CONTRACTOR SHALL BE RESPONSIBLE FOR CHECKING THE PLANS FOR ERRORS BEFORE CONSTRUCTION BEGINS.



**DARBY CLARKE ARCHITECT, INC.**  
 1537 THIRD STREET SLIDELL, LA 70458  
 WWW.CLARKESDESIGN.COM (985) 641-0531

**CLARKE'S DESIGN SERVICE, LLC.**  
 PROJECT DESIGNERS:  
 1537 THIRD STREET SLIDELL, LA 70458  
 WWW.CLARKESDESIGN.COM (985) 641-0531



**PROJECT:**  
 RAWLIN CARTER  
 PRUDENTIAL FINANCIAL ADVISOR  
 1720 W 21ST AVENUE  
 CITY OF COVINGTON, LA.

**CODE:**  
 7408  
**DATE:**  
 03-25-26

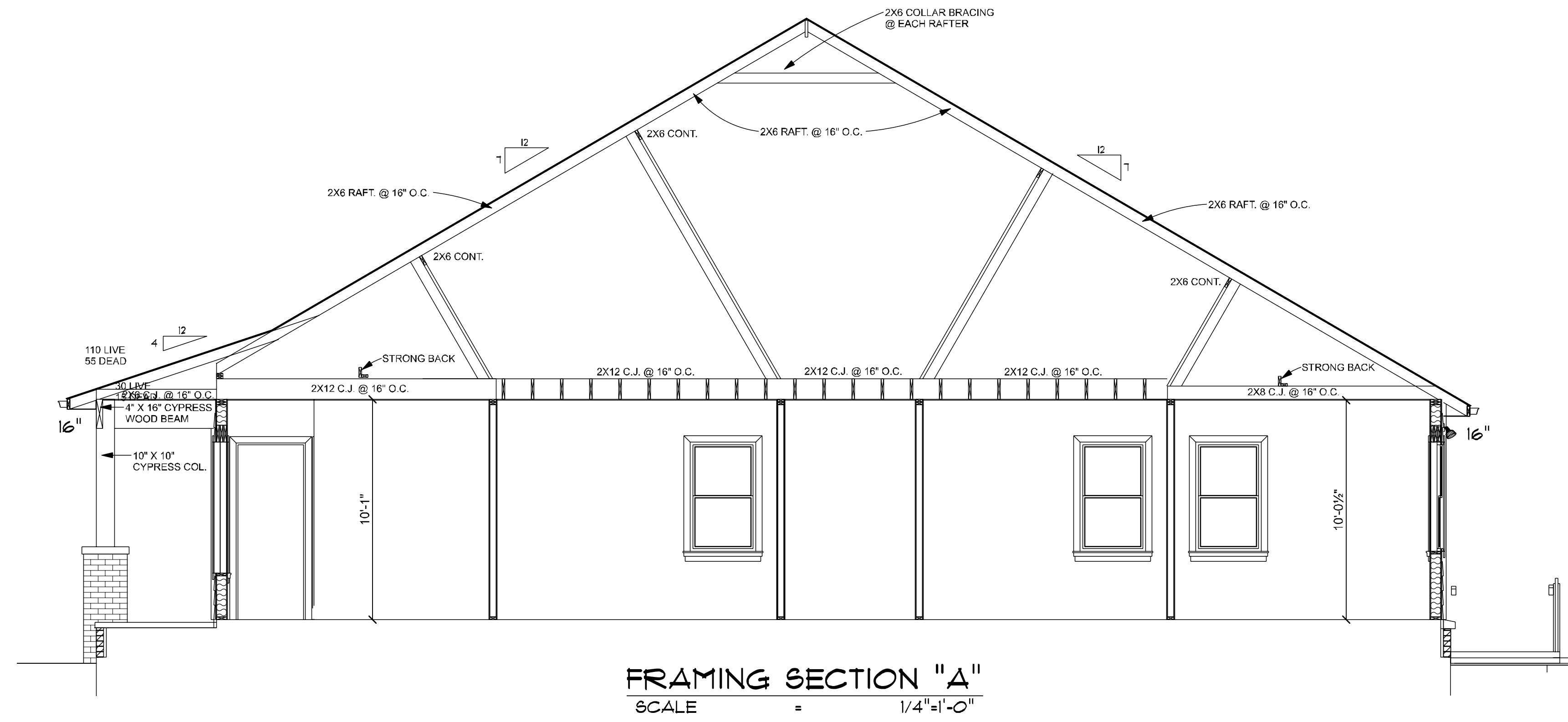
**DESCRIPTION:**  
 ELECTRICAL POWER & DATA DIAGRAM  
**SHEET:**  
 A-E-1

LIVING AREA = 2804  
 FRONT PORCH = 271  
 REAR PORCH = 49  
 TOTAL AREA U.B. = 3124

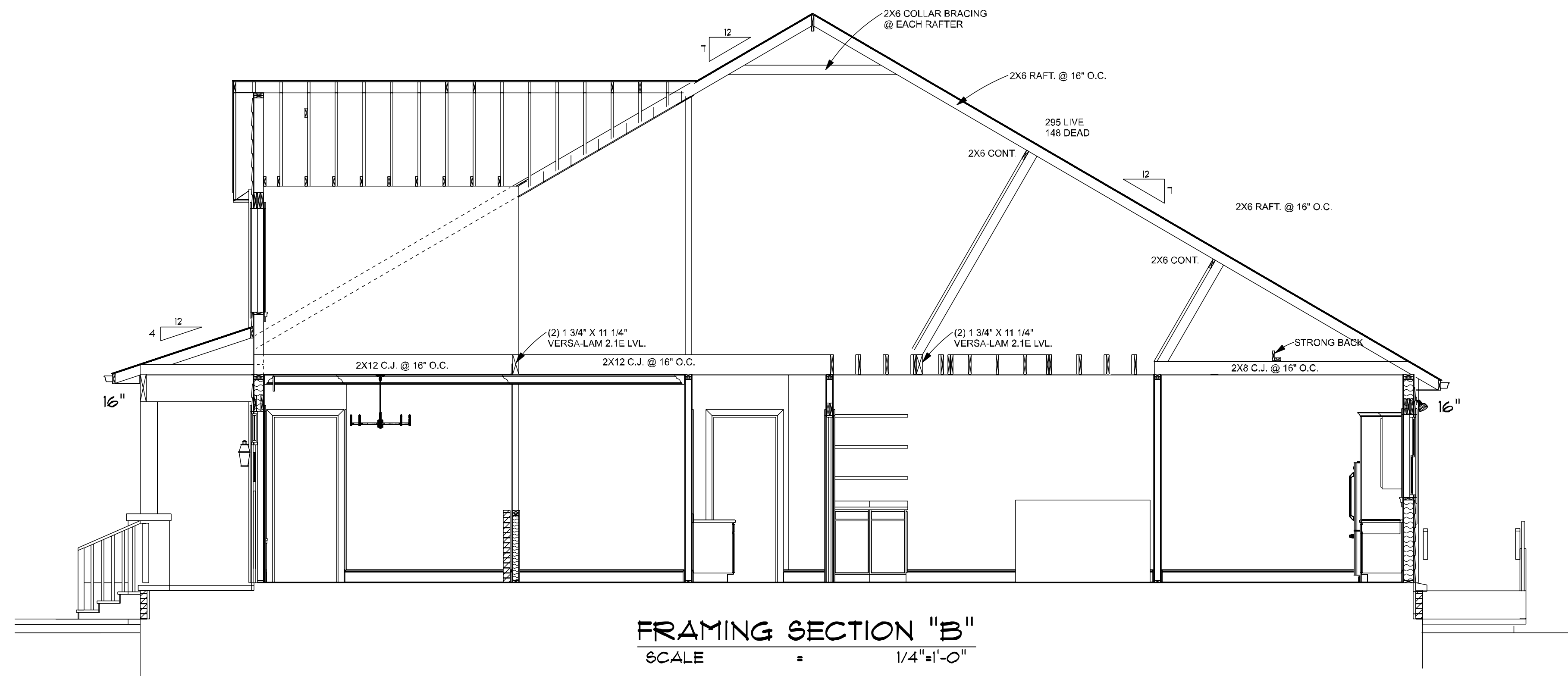
**ELECTRICAL PLAN**  
 SCALE = 1/4"=1'-0"

ELECTRICAL TO EXTERIOR SIGN & AUTOMATIC GATE W/ KEYPAD





**FRAMING SECTION "A"**  
SCALE = 1/4"=1'-0"

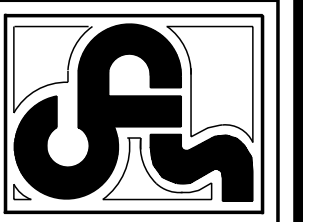


**FRAMING SECTION "B"**  
SCALE = 1/4"=1'-0"

**NOTE:**  
ALTHOUGH EVERY EFFORT  
HAS BEEN MADE IN  
DRAWING THESE  
DRAWINGS, THE  
DRAWING CONTRACTOR  
ULTIMATELY IS RESPONSIBLE  
FOR CHECKING THE PLANS  
FOR CONSTRUCTION AND FOR  
CORRECTING ANY  
ERRORS BEFORE  
CONSTRUCTION BEGINS.



PROJECT DESIGNERS:  
**CLARKE'S DESIGN SERVICE, LLC.**  
1537 THIRD STREET SLIDELL, LA 70458  
WWW.CLARKEDESIGN.COM (985) 641-0531



PROJECT:  
RAWLIN CARTER  
PRUDENTIAL FINANCIAL ADVISOR  
1720 W 21ST AVENUE  
CITY OF COVINGTON, LA.

CODE:  
7408  
DATE:  
03-25-26

DESCRIPTION:  
FRAMING  
SECTIONS  
A & B  
SHEET:  
S2



NOTE:  
ALTHOUGH EVERY EFFORT  
HAS BEEN MADE IN  
PREPARING THESE  
DRAWINGS, THE  
DESIGNER SHALL NOT BE  
ULTIMATELY RESPONSIBLE  
FOR CHECKING THE PLANS  
FOR ERRORS BEFORE  
CONSTRUCTION BEGINS.



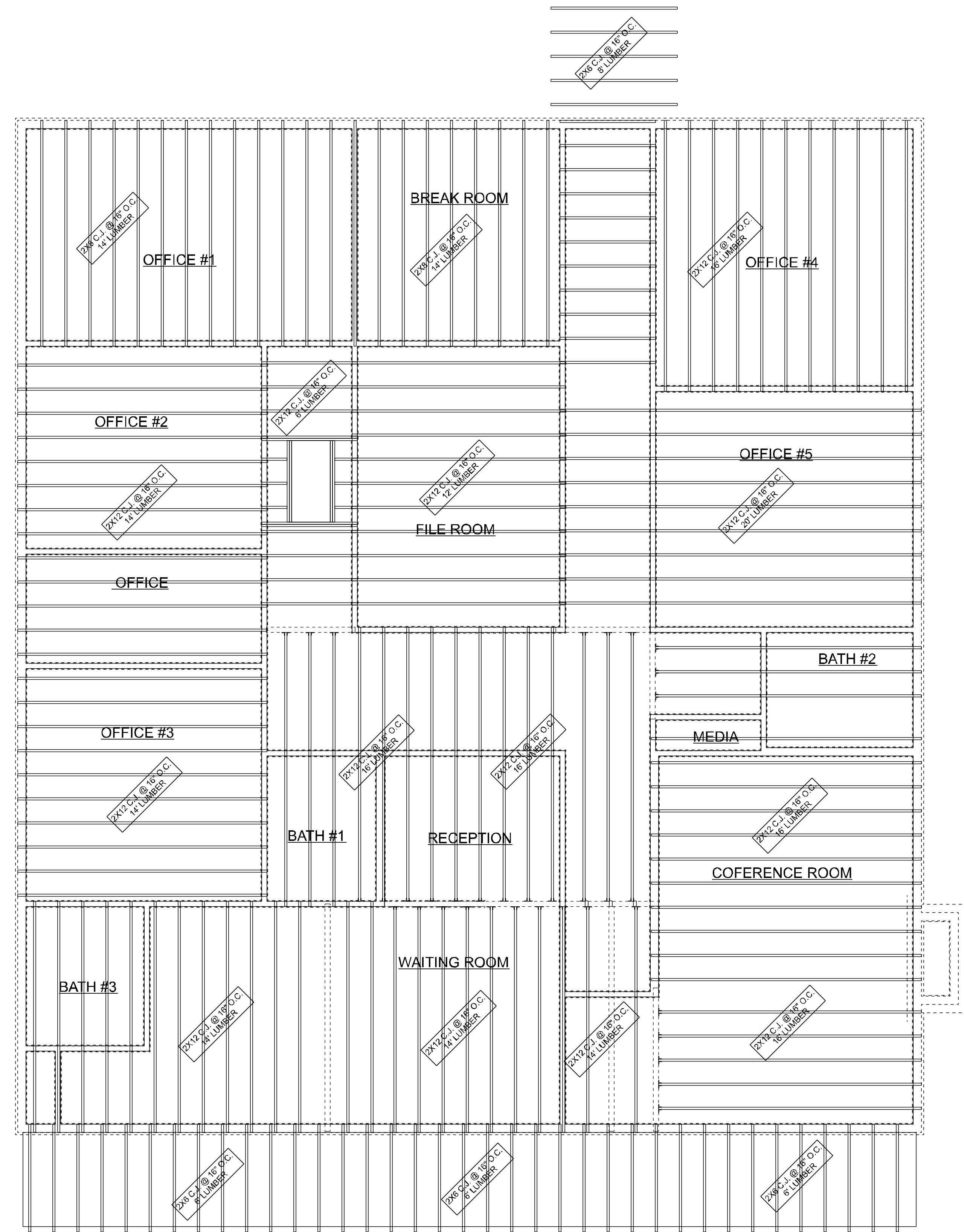
PROJECT DESIGNERS:  
**CLARKE'S DESIGN SERVICE, LLC.**  
1537 THIRD STREET SLIDELL, LA 70458  
WWW.CLARKESDESIGN.COM (985) 641-0531

PROJECT:  
RAWLIN CARTER  
PRUDENTIAL FINANCIAL ADVISOR  
1720 W 21<sup>ST</sup> AVENUE  
CITY OF COVINGTON, LA.

CODE:  
7408  
DATE:  
03-25-26

DESCRIPTION:  
CEILING  
JOIST PLAN

SHEET:  
S4



**CEILING JOIST PLAN**

SCALE = 1/4"=1'-0"

CODES AND DESIGN SPECIFICATIONS  
BUILDING CODE: INTERNATIONAL BUILDING CODE (IBC) 2021  
NATIONAL DESIGN SPECIFICATION FOR WOOD FRAMED CONSTRUCTION 2018  
ASCE 7-16

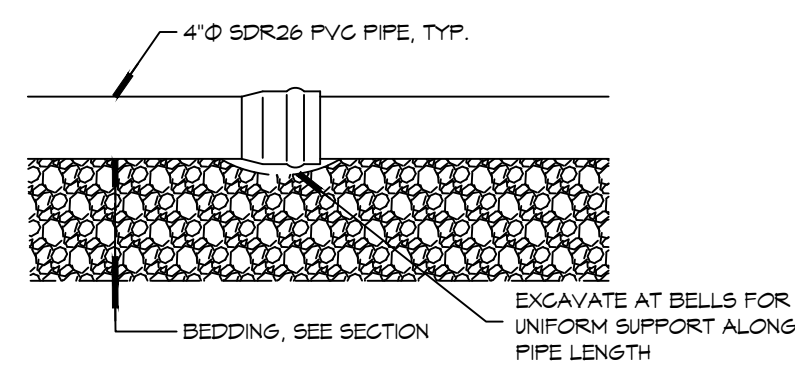
DESIGN LOADS

- ROOF DESIGN LOADS
- CEILING COLLATERAL DEAD LOAD = 10 PSF
- CEILING LIVE LOAD = 20 PSF
- ROOF COLLATERAL DEAD LOAD = 10 PSF
- ROOF LIVE LOAD = 20 PSF
- WIND LOAD CRITERIA
- ULTIMATE WINDSPEED = 140 MPH
- NOMINAL WINDSPEED = 108 MPH
- OCCUPANCY CATEGORY = II
- EXPOSURE = B
- INTERNAL PRESSURE COEFFICIENT = +/- 0.18

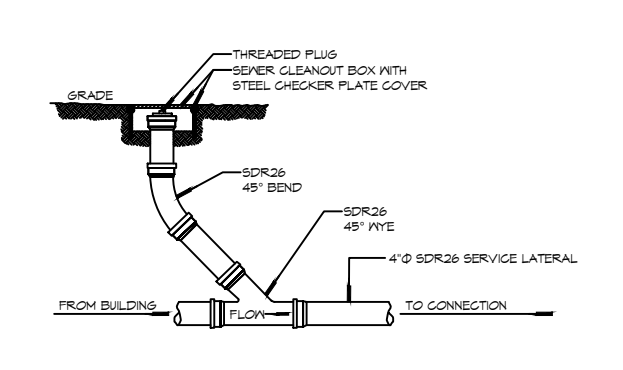
TOTAL SHEAR PERPENDICULAR TO LENGTH = 81 KIP (ULTIMATE)  
TOTAL SHEAR PERPENDICULAR TO WIDTH = 22 KIP (ULTIMATE)



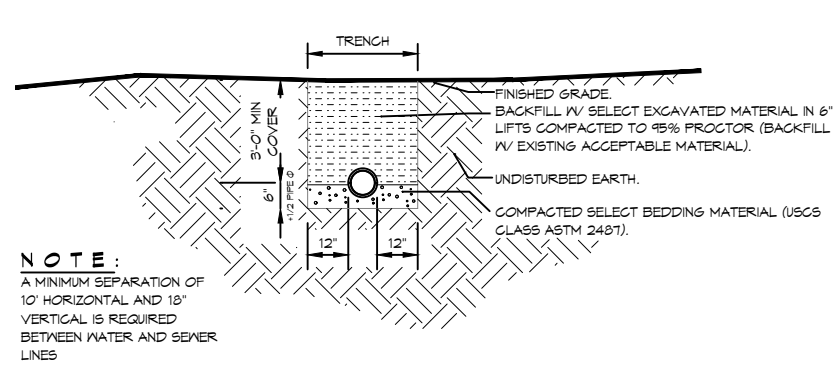




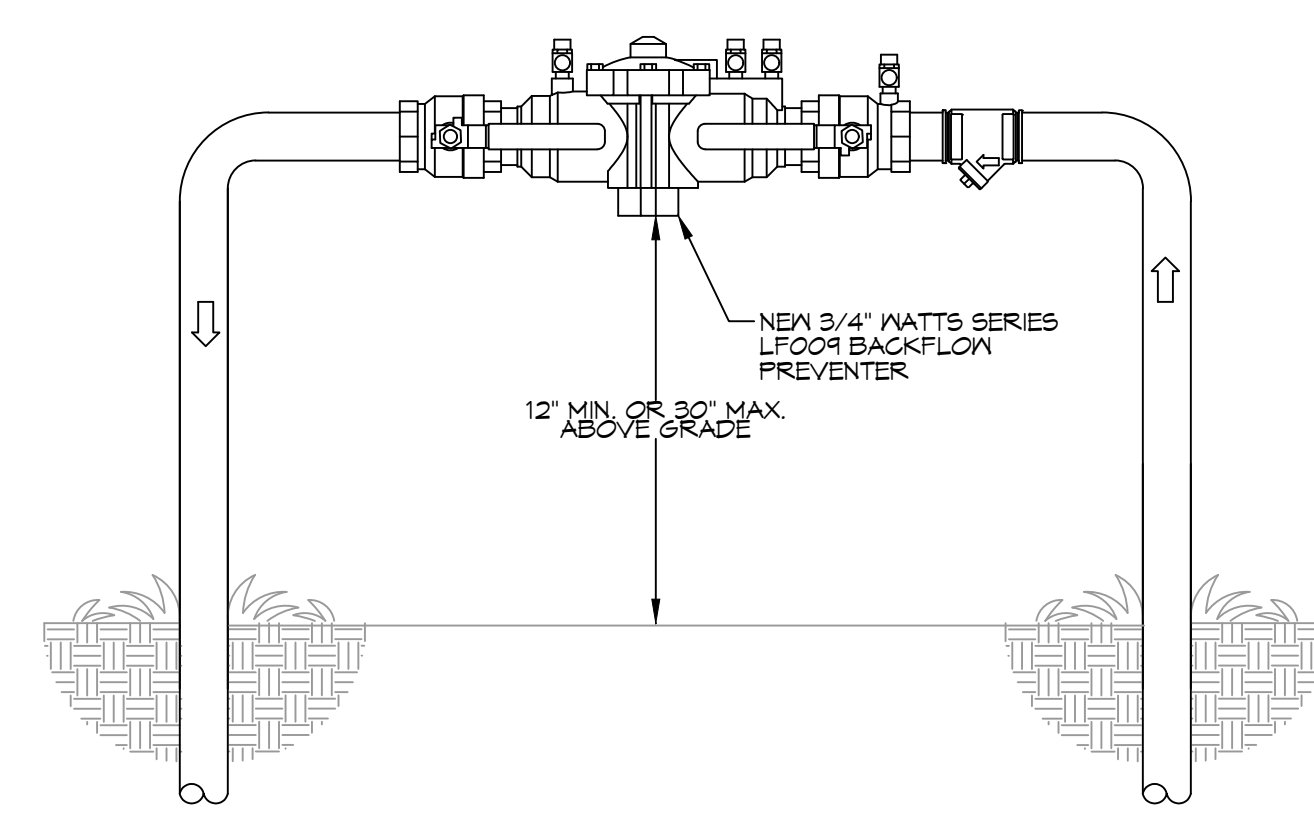
**DETAIL**  
SCALE: N.T.S.  
TYPICAL PIPE BEDDING



**DETAIL**  
SCALE: N.T.S.  
SEWER CLEAN OUT



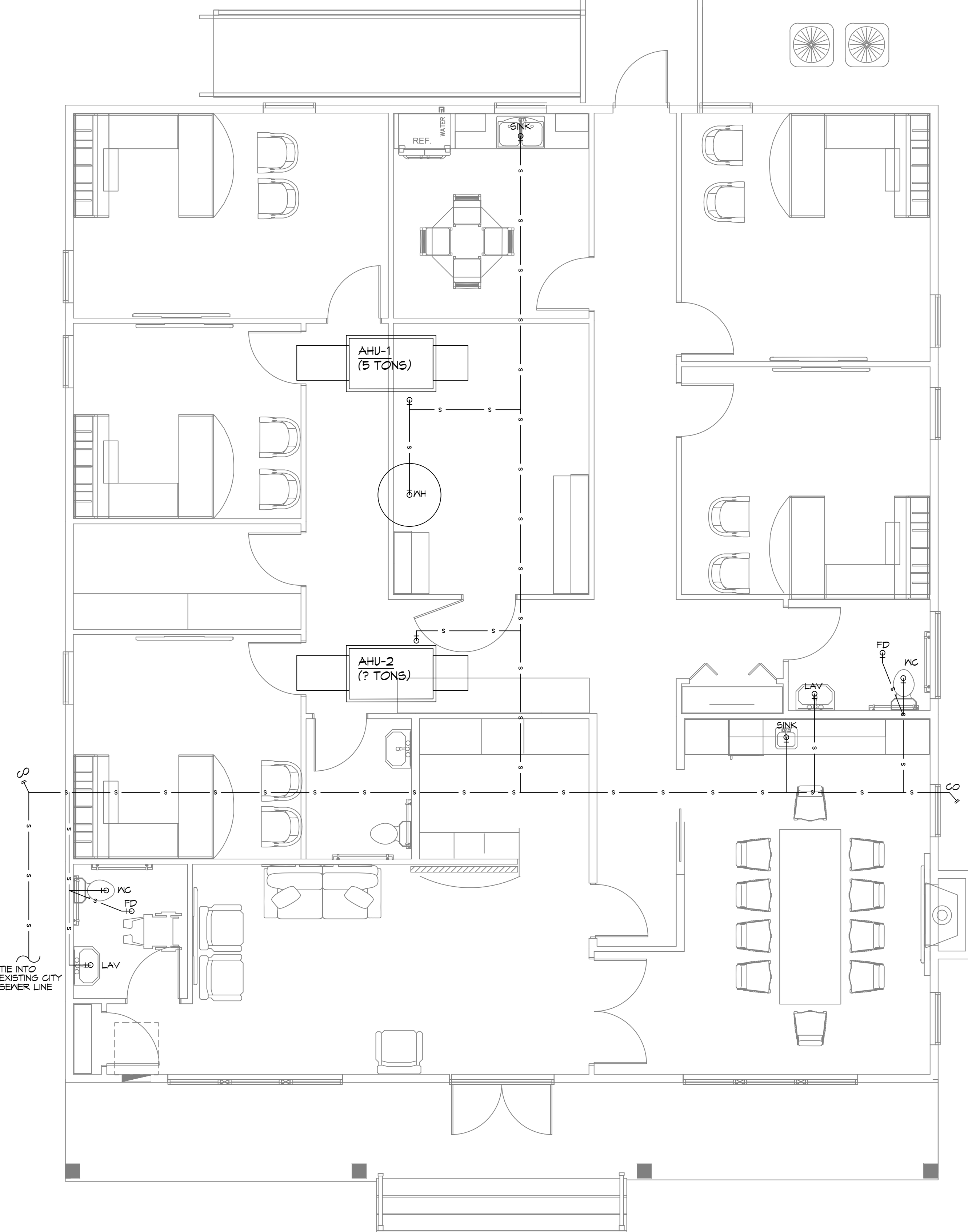
**DETAIL**  
SCALE: N.T.S.  
SEWER AND WATER SEPERATION



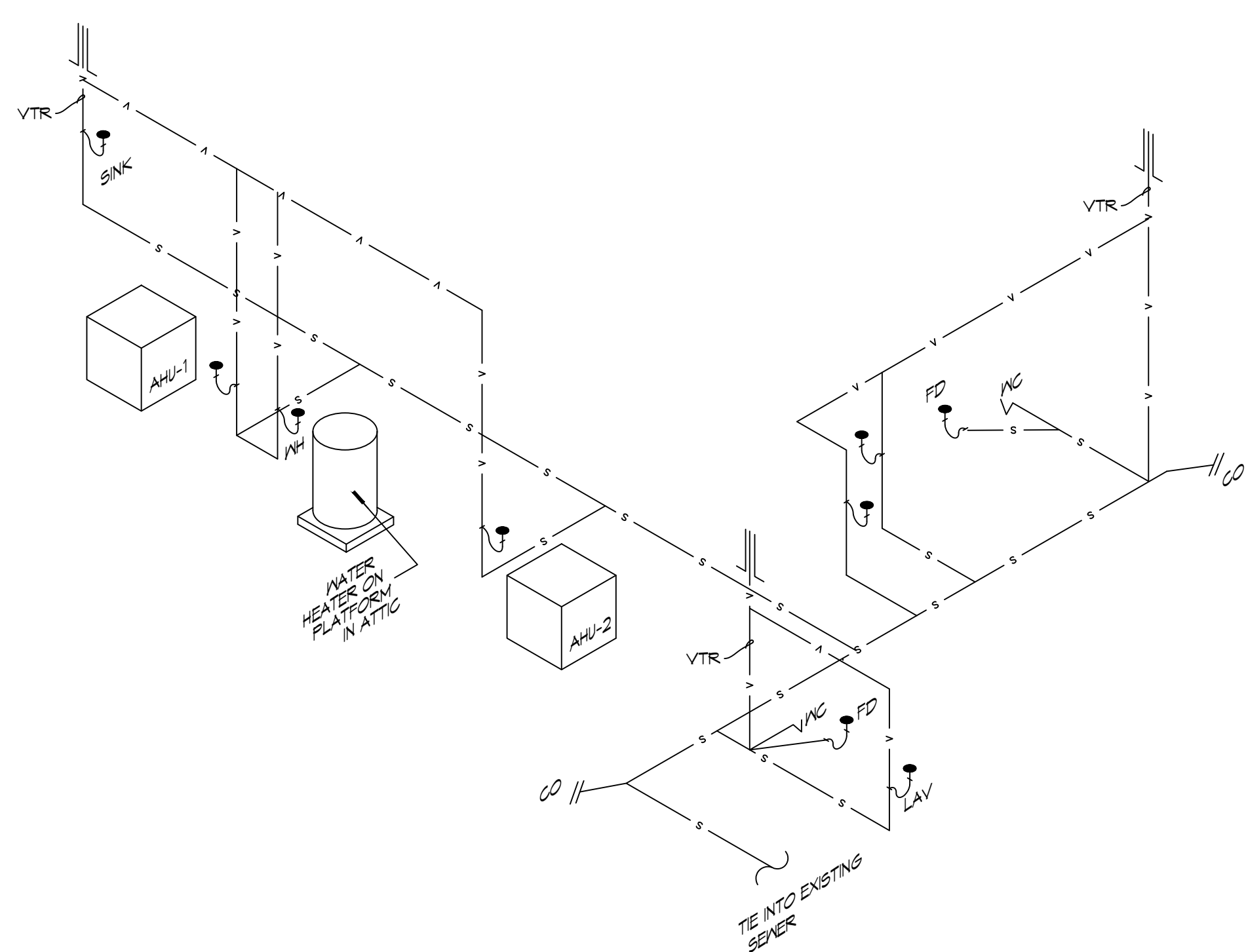
**TYPICAL BACKFLOW DETAIL**  
SCALE: N.T.S.

**GENERAL PLUMBING NOTES**

1. PLUMBING LINES SHOWN ARE DRAWN DIAGRAMMATIC IN NATURE AND REPRESENT CONCEPTUAL ROUTING ONLY. CONTRACTOR IS RESPONSIBLE FOR FIELD VERIFICATION OF ALL ACTUAL CONDITIONS.
2. PROVIDE ALL LABOR, MATERIAL, TRANSPORTATION, SUPERVISION, CLEAN-UP, SERVICES, AND EQUIPMENT FOR A COMPLETE OPERATING SYSTEM. THE SYSTEM SHALL INCLUDE HOT AND COLD WATER PIPING, SEWER AND VENT PIPING, INSULATION, WATER HEATER, HANGERS, VALVES, SUPPORTS WITHOUT ANY RESTRICTIONS TO VOLUME, CUT AND PATCH AS REQUIRED TO INSTALL PIPES.
3. ALL WORK AND MATERIAL SHALL CONFORM STRICTLY TO THE LATEST LOCAL CITY, PARISH, STATE AND NATIONAL GOVERNING CODES. MUST MEET LA STATE PLUMBING CODE 2013 REQUIREMENTS.
4. CONTRACTOR IS TO FIELD VERIFY ALL EXISTING UTILITY LOCATIONS, ELEVATIONS AND SIZES PRIOR TO COMMENCING ANY WORK. CONTRACTOR SHALL PAY NECESSARY FEES FOR THE UTILITIES CONNECTIONS.
5. CONTRACTOR IS RESPONSIBLE TO VERIFY THE EXISTING INVERTS AND SET NEW INVERTS OF SEWERAGE AND DRAINAGE PIPES.
6. SEWERAGE LINES 3-INCH AND SMALLER SHALL BE SLOPED 1/4" PER FOOT AND LINES 4-INCH AND LARGER SHALL BE 1/8" PER FOOT.
7. TEST ALL PIPING AT REQUIRED PRESSURE.
8. ALL PLUMBING SHALL BE CLOSELY COORDINATED WITH STRUCTURAL, MECHANICAL SYSTEM AND ELECTRICAL SYSTEMS TO INSURE NO TRADES WILL CONFLICT WITH EACH OTHER.
9. DO NOT SCALE DRAWINGS. SEE ARCHITECTURAL DRAWINGS FOR EXACT LOCATIONS OF DOORS, WINDOWS, WALLS, FIXTURES, ETC.
10. ALL WATER MAINS AND PIPING NOT SHOWN FOR CLARITY, ALL LOCATIONS FIELD VERIFIED.
11. DOMESTIC HOT AND COLD WATER PIPING AND FITTINGS UNDER SLAB SHALL BE ASTM B88 COPPER WATER TUBE, TYPE K, SOFT ANNEALED. NO JOINTS SHALL BE ALLOWED UNDER THE SLAB.
12. DOMESTIC WATER PIPING AND FITTINGS ABOVE THE SLAB SHALL BE ASTM B88 COPPER WATERTUBE, TYPE L. HARD DRAWN WITH COPPER PRESSURE TYPE FITTINGS, ANSI B16.22. THE JOINTS SHALL BE SOLDERED TYPE USING ASTM B32, ALLOY GRADE #5A (95-5) SOLDER.
13. SOIL, WASTE, VENT PIPING AND FITTINGS ABOVE THE SLAB SHALL BE SERVICE WEIGHT CAST IRON PIPE WITH BELL AND SPIGOT ENDS AND ONE PIECE NEOPRENE INSERT TYPE GASKET. USE PVC SCHEDULE 40 OR ABS DIAV PIPES AND FITTINGS WHERE PERMITTED BY CODE.
14. ALL WATER PIPING AND FITTINGS ABOVE THE FLOOR SHALL BE INSULATED WITH 1/2" THICK FIBERGLASS INSULATION AND JACKET.
15. ALL ELECTRICAL, MECHANICAL AND PLUMBING ELEMENTS PENETRATING FIRE PARTITIONS SHALL BE FIRE CAULKED. (PENETRATIONS THROUGH RATED CONSTRUCTION SHALL BE SEALED WITH A MATERIAL CAPABLE OF PREVENTING THE PASSAGE OF FLAMES AND HOT GASES WHEN TESTED IN ACCORDANCE WITH ASTM-E814.)
16. SEE ROOF PLAN FOR PLUMBING ROOF PENETRATIONS. ROUTE VENT PIPES IN ATTIC AS NECESSARY.
17. ALL VENTS THROUGH ROOF (VTR) SHALL BE LOCATED A MINIMUM OF 10'-0" FROM ANY MECHANICAL OR NATURAL AIR INTAKE.



**1 OFFICE PLUMBING PLAN**  
SCALE: 1/4"=1'-0"

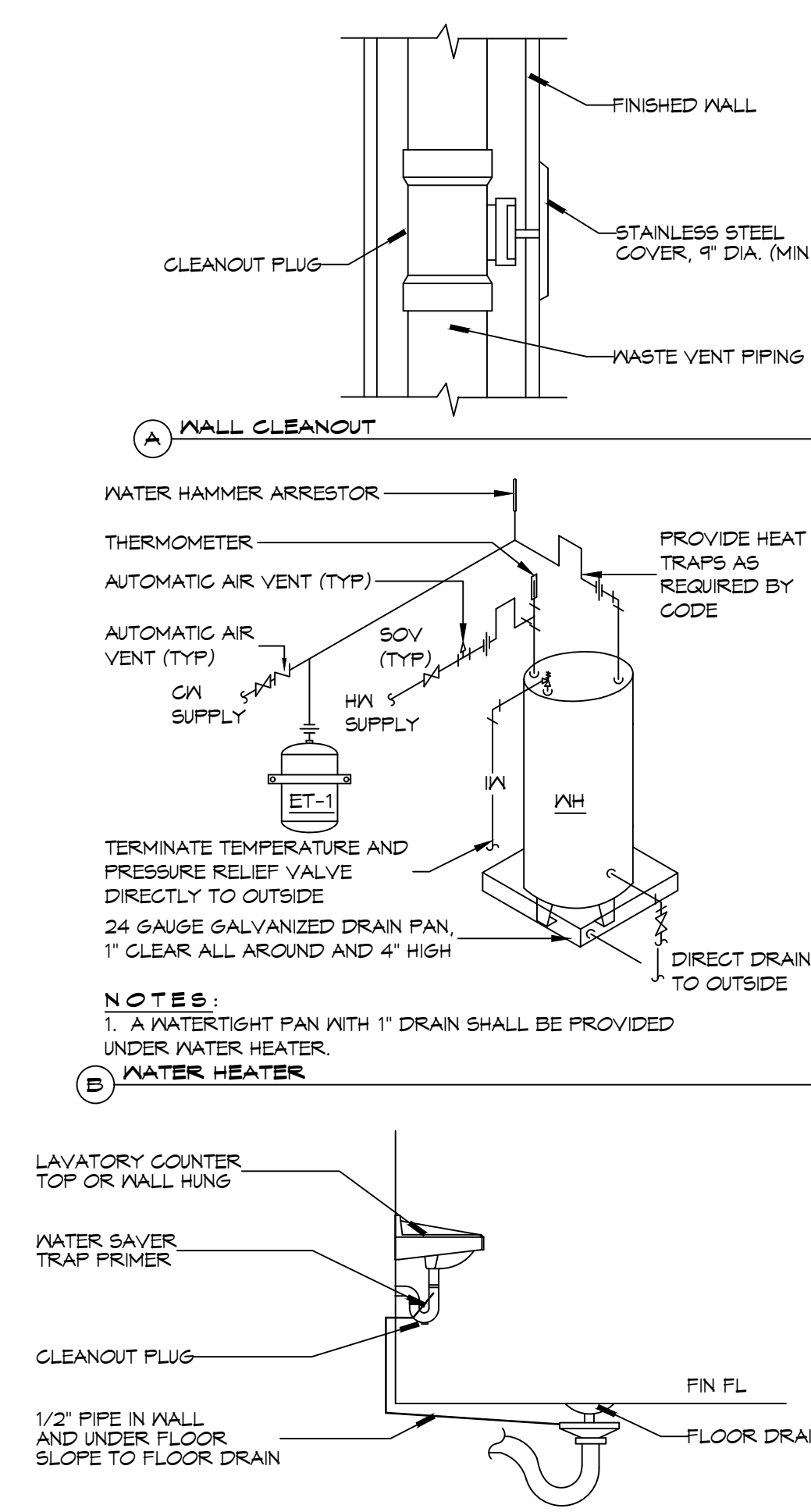


**2 PLUMBING RISER DIAGRAM**  
SCALE: N.T.S.

PLUMBING ABBREVIATIONS			
HS	HAND SINK	MS	MOP SINK
LAV	LAVATORY	MH	WATER HEATER (PLACED IN ATTIC)
WC	WATER CLOSET		

LEGEND	
— s — s —	SEWER LINE
— v — v —	VENT PIPE
— e —	ELBOW UP
FD	FLOOR DRAIN
— CO —	CLEAN OUT



**TYPICAL DETAILS**  
SCALE: N.T.S.  
MISCELLANEOUS PLUMBING

**DAMMON ENGINEERING, INC.**  
LOUISIANA & MISSISSIPPI

Chief Engineer: Brian Mistich, PE  
554 Old Spanish Trail  
Slidell, LA 70458  
www.dammonengineering.com  
info@dammonengineering.com  
PH: 985.649.5832

DATE	REVISIONS
	# DESCRIPTION



**RANLIN CARTER**

PROJECT: OFFICE PLUMBING PLAN AND PLUMBING RISER DIAGRAM

1720 W 21ST AVENUE  
COVINGTON, LA 70433

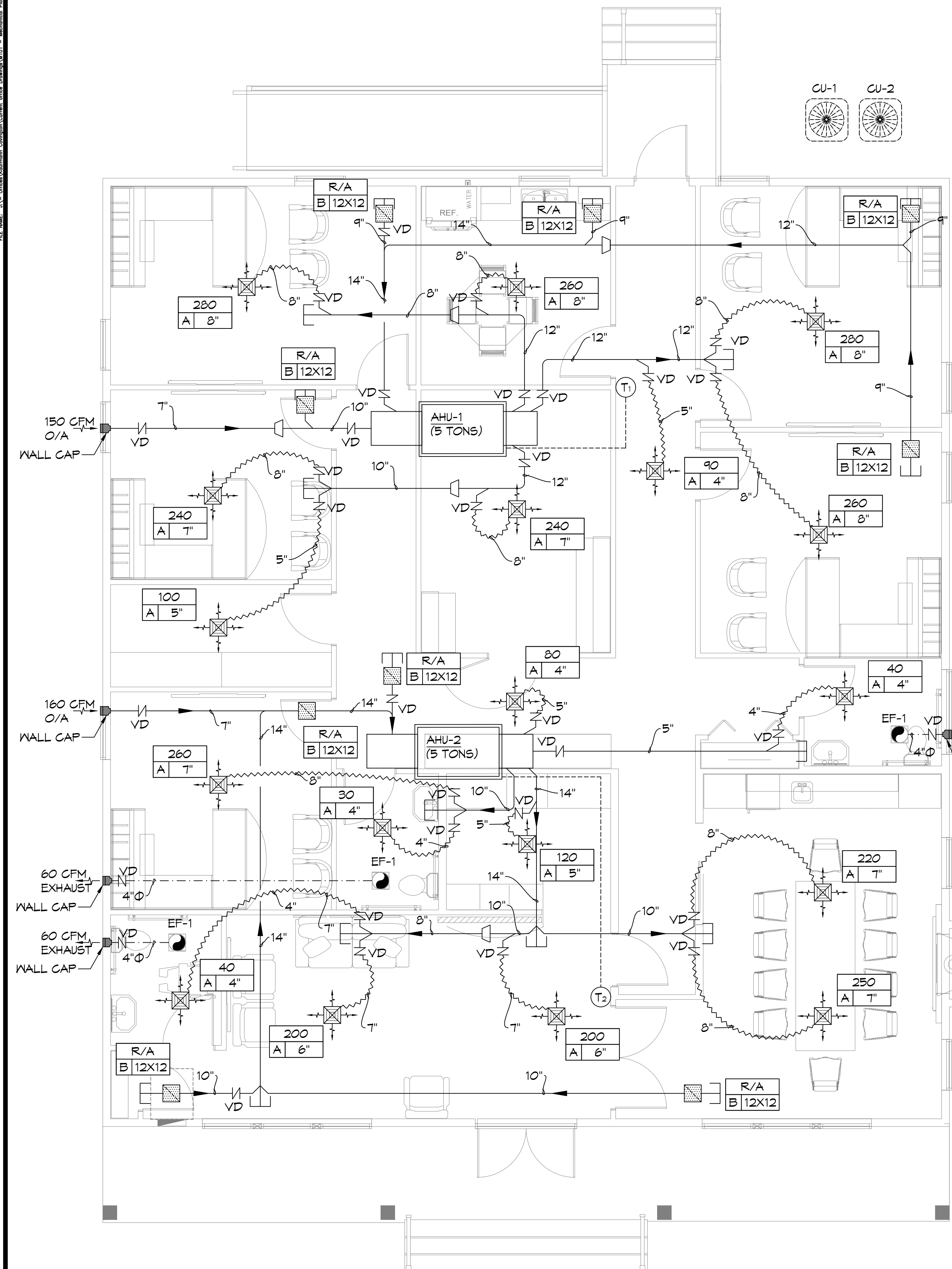
JOB NO: 2026 DATE: 05-28-2026  
DRAWN BY: CAD CHECKED BY: BAXI

SHEET TITLE: OFFICE PLUMBING PLAN AND PLUMBING RISER DIAGRAM

DRAWING NUMBER: **P101**

SHEET No: 1 of 9

FILE NAME: J:\Projects\10 Office Mechanical\10 Office Mechanical.dwg DATE: 03/26/2026 10:08:35 AM



DX SPLIT SYSTEM SCHEDULE																		
AIR HANDLER							CONDENSER											
TAG	MAKE	MODEL	NOMINAL TONS	TOTAL AIRFLOW (CFM)	O/A Air (CFM)	ESP (\"WC)	HEAT (KW)	POWER VAC	PH	MCA	TAG	NOMINAL TONS	MAKE	MODEL	POWER VAC	PH	MCA	REMARKS
AHU-1	Trane	STEMC007AV	5	1750	150	0.4	3.6	208	1	29	CU-1	5	Trane	5TRR3060A1	208	1	50	1, 2
AHU-2	Trane	STEMC007AV	5	1440	160	0.4	5.7	208	1	42	CU-2	5	Trane	5TRR3060A1	208	1	50	1, 2

DIFFUSER SCHEDULE				
TAG	SERVICE	NECK SIZE	DESCRIPTION	Remarks
A	Supply Air	Ref. Plan	12\"x 12\" Adjustable Square Cone Diffuser, Price ASCDA or equal w/ Insulated Back Panel	1, 2, 3
B	Return Air	Ref. Plan	12\"x 12\" Louvered Face Filter Return Air Grille, Price 70 FH or equal w/ MERV 8 filter	1, 2, 3

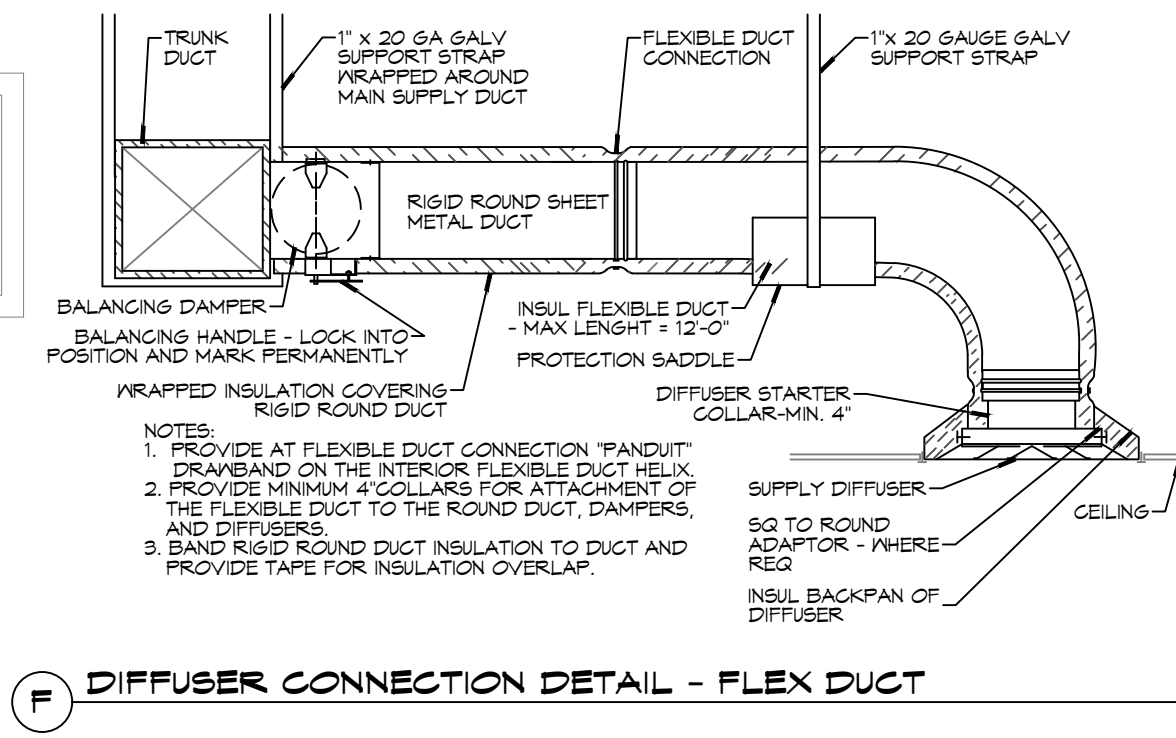
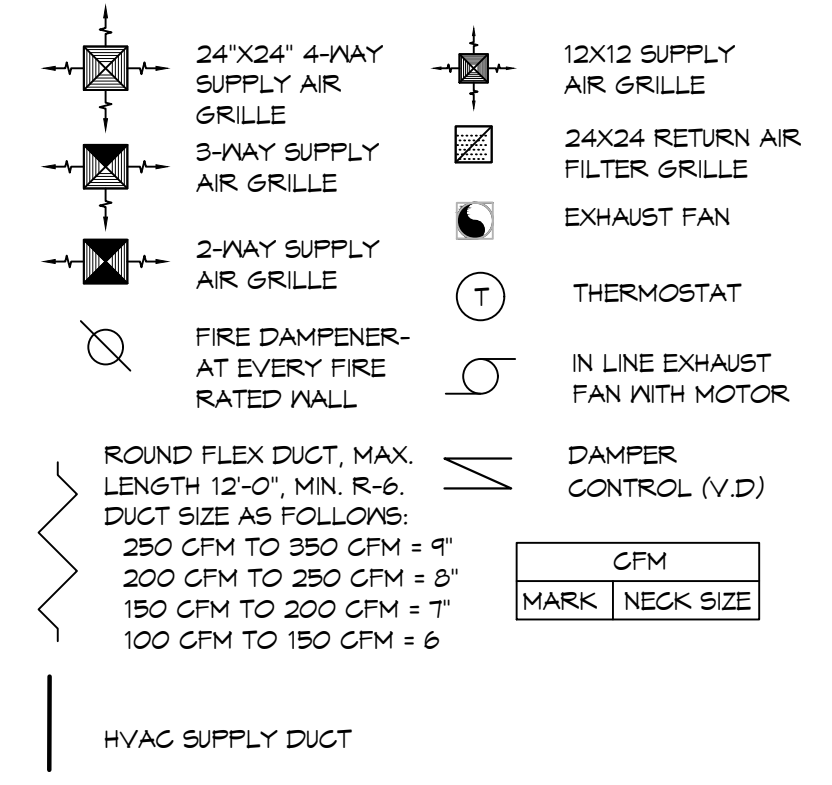
EXHAUST FAN SCHEDULE										
TAG	AIRFLOW (CFM)	SERVICE	TSP (\"wc)	AMPS	WATTS	VAC	PH	HZ	MAKE / MODEL	REMARKS
EF-1	60	Restroom	0.1	0.2		120	1	60	Broan BE6	1

**MECHANICAL SCHEDULES**  
SCALE: 1/4\"=1'-0\"

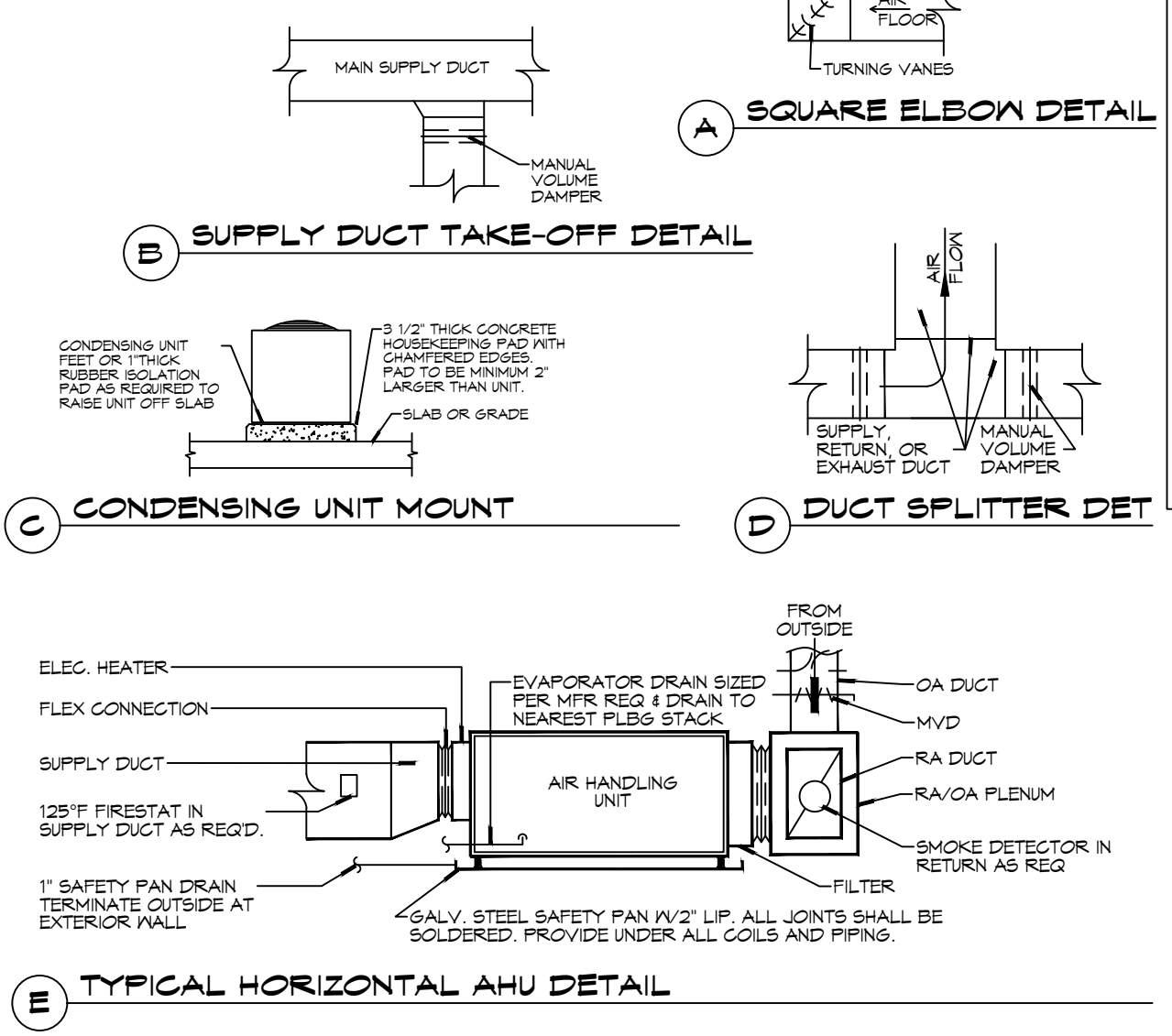
**GENERAL HVAC NOTES**

- CONCEALED DUCTWORK TO BE GALVANIZED SHEET METAL WRAPPED WITH FIBROUS GLASS DUCT WRAP WITH FSK VAPOR BARRIER, MIN R-6. INSTALLED PER SMACNA STANDARDS. DUCT WORK IMMEDIATELY DOWNSTREAM FROM RTU SHALL BE LINED FOR SOUND ATTENUATION.
- EXPOSED DUCTWORK TO BE GALVANIZED SHEET METAL LINED WITH FIBROUS GLASS DUCT LINER, MIN R-6. INSTALLED PER SMACNA STANDARDS.
- ROUND FLEXIBLE DUCT TO BE UL-181, CLASS 1, AIR DUCT MATERIALS.
- DUCT SIZES SHOWN ARE CLEAR INSIDE DIMENSIONS.
- IN ALL SYSTEMS OVER 2000 CFM AND LESS THAN 15,000 CFM, SMOKE DETECTORS SHALL BE INSTALLED IN ACCORDANCE WITH NFPA 12E IN THE RETURN DUCT DOWNSTREAM OF THE AIR HANDLING UNIT AND ALL FILTERS TO AUTOMATICALLY STOP THE FAN.
- PROVIDE UL LISTED 125\" F FIRESTAT IN RETURN AIR OF EACH SYSTEM UNDER 2000 CFM TO SHUT DOWN THE FAN IN THE EVENT OF FIRE.
- PROVIDE UL RATED FIRE DAMPERS WHERE REQUIRED AT ALL DUCT PENETRATIONS OF FIRE-RATED ASSEMBLIES AND WHERE REQUIRED BY CODE, INCLUDING OUTSIDE AIR INTAKES AND EXHAUST FANS.
- CONDENSATE DRAINS TO BE PVC PIPE RUN TO PLUMBERS P-TRAP WITHIN FIVE FEET OF AIR HANDLING UNITS.
- ALL AIR HANDLING SYSTEMS TO BE BALANCED TO ASSURE PROPER AIR FLOWS PER PLANS.
- ALL THERMOSTATS TO BE AUTOMATIC CHANGEOVER WITH HEAT SWITCH.
- EXHAUST FAN SHALL BE CONTROLLED BY A SWITCH ON THE WALL IN THE SAME LOCATION AS LIGHT SWITCH(S). PROVIDE BACK DRAFT DAMPER.
- PROVIDE AND INSTALL WATER PROOF GRILLE VENT IN PROPER ROOF LOCATION FOR PLUMBING FIXTURE EXHAUST.
- ALL SUPPLY AIR VENTS SHALL BE EQUIPPED WITH AIR CONTROL DAMPERS AT THE REGISTER.
- LOCATE OUTDOOR UNITS AS SHOWN ON ARCHITECTURAL DRAWINGS.
- REFRIGERANT LINES SHALL BE SIZED BY UNIT MANUFACTURER AND INSTALLED ACCORDING TO MANUFACTURER'S INSTRUCTIONS.
- FRESH AIR SHALL BE SUPPLIED TO EACH AIR HANDLER THROUGH EXTERIOR WALL DUCT SUPPLIED WITH A CONTROL DAMPER.
- ALL ELECTRICAL, MECHANICAL, AND PLUMBING PENETRATING FIRE WALLS SHALL BE FIRE CAULKED. PENETRATIONS THROUGH RATED CONSTRUCTION SHALL BE SEALED WITH A MATERIAL CAPABLE OF PREVENTING THE PASSAGE OF FLAMES AND HOT GASES WHEN TESTED IN ACCORDANCE WITH ASTM-E8-14).
- ALL MECHANICAL SYMBOLS ARE DRAWN DIAGRAMMATICALLY. CONTRACTOR TO VERIFY WITH OWNER LOCATIONS OF VENTS, DAMPERS, REGISTERS, ETC.
- FLEXIBLE DUCTWORK LENGTH NOT TO EXCEED 12'-0\". SUPPORT FLEX DUCT TO PREVENT SAGGING.
- REFER TO REFLECTED CEILING PLAN FOR FINAL GRILLE AND DIFFUSER LOCATIONS AND COORDINATE AS REQUIRED.
- FINAL LOCATION OF TEMPERATURE CONTROLS TO BE COORDINATED WITH OWNER AT JOB SITE.
- PROVIDE AND INSTALL SMOKE DETECTORS AS APPROVED BY LOCAL A.H.J.S. PLACE NEAR R/A AND S/A OPENINGS OF AHU AND PROVIDE, WITH ACCESS PANEL, WIRING BY ELECTRICAL CONTRACTOR.
- FRESH AIR INTAKES ARE REQUIRED TO HAVE MOTORIZED OR GRAVITY DAMPERS TO SHUT OFF WHEN SYSTEM IS NOT RUNNING.
- PROVIDE BIRD SCREENS AT ALL EXTERIOR MECHANICAL PENETRATIONS.
- COORDINATE WALL MOUNTED THERMOSTAT LOCATIONS WITH ALL OWNER FURNISHED ITEMS EITHER WALL MOUNTED OR FLOOR MOUNTED AGAINST PARTITIONS. REFER TO ARCHITECTURAL DRAWINGS.
- SEE ROOF PLAN FOR ALL ROOF PENETRATIONS.
- PROVIDE MIN 18 GA GALVANIZED SHEET METAL TO BLANK-OFF GABLE VENTS WHERE INTAKE/EXHAUST DUCTS OCCUR.

**MECHANICAL LEGEND**



**DETAILS**  
SCALE: N.T.S.



**10 OFFICE MECHANICAL PLAN**  
SCALE: 1/4\"=1'-0\"

**DAMMON ENGINEERING, INC.**  
LOUISIANA & MISSISSIPPI  
Chief Engineer: Brian M. Mistry, PE  
554 Old Spanish Trail  
Slidell, LA 70458  
www.dammonengineering.com  
info@dammonengineering.com  
PH: 985.649.5832

DATE	REVISIONS	DESCRIPTION

**NEW OFFICE AND APARTMENT RENTAL CARTER**

1700 W. 21ST AVENUE  
COVINGTON, LA 70433  
JOB No: 2026-0026  
DATE: 03-26-2026  
DRAWN BY: CKP  
CHECKED BY: BAY

SHEET TITLE:  
**OFFICE MECHANICAL PLAN**

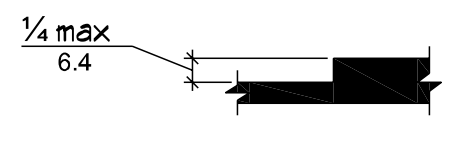
DRAWING NUMBER:  
**M101**

SHEET No: 3 of 3







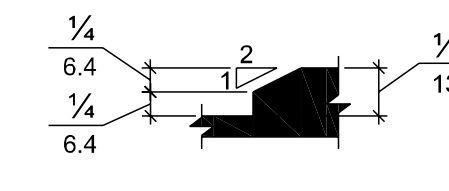


**Figure 303.2**  
Vertical Change in Level

Figure 303.2 Vertical Change in Level

303.2 Vertical. Changes in level of 1/4 inch (6.4 mm) high maximum shall be permitted to be vertical.

303.3 Beveled. Changes in level of 1/4 inch (6.4 mm) high minimum and 1/2 inch (13 mm) high maximum shall be beveled with a slope not steeper than 1:2.



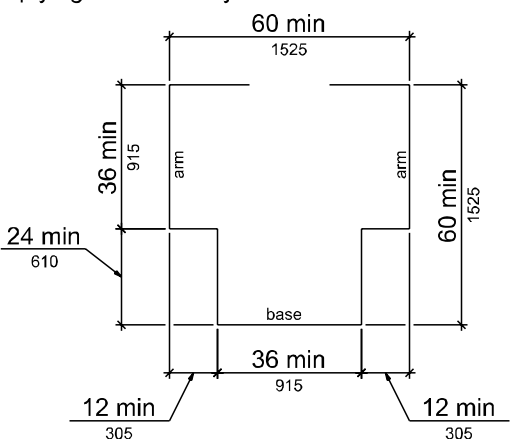
**Figure 303.3**  
Beveled Change in Level

Figure 303.3 Beveled Change in Level

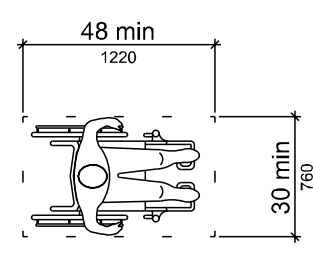
304 Turning Space

304.3.1 Circular Space. The turning space shall be a space of 60 inches (1525 mm) diameter minimum. The space shall be permitted to include knee and toe clearance complying with 306.

304.3.2 T-Shaped Space. The turning space shall be a T-shaped space within a 60 inch (1525 mm) square minimum with arms and base 36 inches (915 mm) wide minimum. Each arm of the T shall be clear of obstructions 12 inches (305 mm) minimum in each direction and the base shall be clear of obstructions 24 inches (610 mm) minimum. The space shall be permitted to include knee and toe clearance complying with 306 only at the end of either the base or one arm.

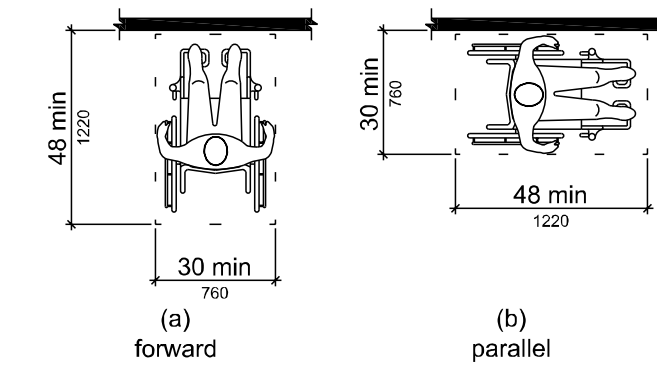


**Figure 304.3.2**  
T-Shaped Turning Space



**Figure 305.3**  
Clear Floor or Ground Space

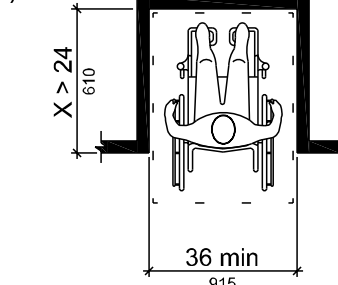
Figure 305.3 Clear Floor or Ground Space



**Figure 305.5**  
Position of Clear Floor or Ground Space

Figure 305.5 Position of Clear Floor or Ground Space

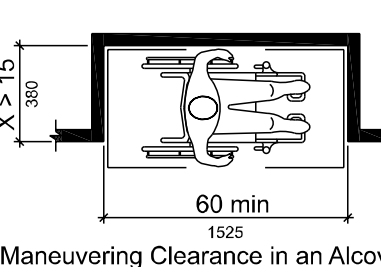
305.7.1 Forward Approach. Alcoves shall be 36 inches (915 mm) wide minimum where the depth exceeds 24 inches (610 mm).



**Figure 305.7.1**  
Maneuvering Clearance in an Alcove, Forward Approach

Figure 305.7.1 Maneuvering Clearance in an Alcove, Forward Approach

305.7.2 Parallel Approach. Alcoves shall be 60 inches (1525 mm) wide minimum where the depth exceeds 15 inches (380 mm).



306 Knee and Toe Clearance

306.2 Toe Clearance.

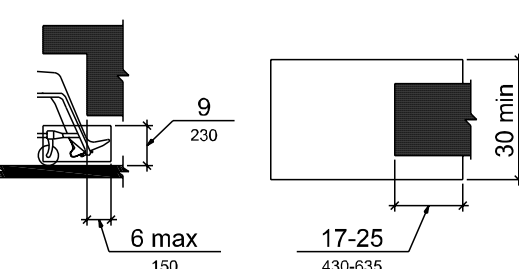
306.2.1 General. Space under an element between the finish floor or ground and 9 inches (230 mm) above the finish floor or ground shall be considered toe clearance and shall comply with 306.2.

306.2.2 Maximum Depth. Toe clearance shall extend 25 inches (635 mm) maximum under an element.

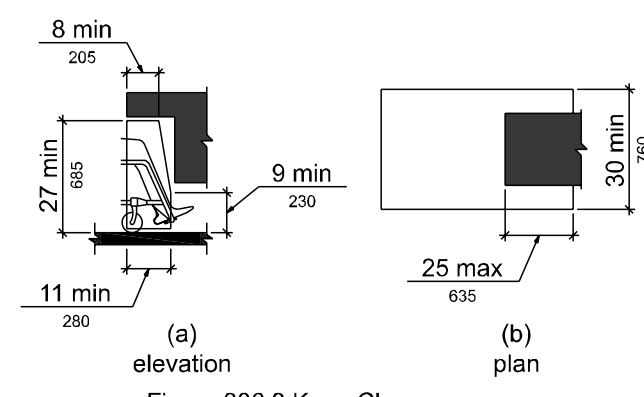
306.2.3 Minimum Required Depth. Where toe clearance is required at an element as part of a clear floor space, the toe clearance shall extend 17 inches (430 mm) minimum under the element.

306.2.4 Additional Clearance. Space extending greater than 6 inches (150 mm) beyond the available knee clearance at 9 inches (230 mm) above the finish floor or ground shall not be considered toe clearance.

306.2.5 Width. Toe clearance shall be 30 inches (760 mm) wide minimum.



**Figure 306.2**  
Toe Clearance



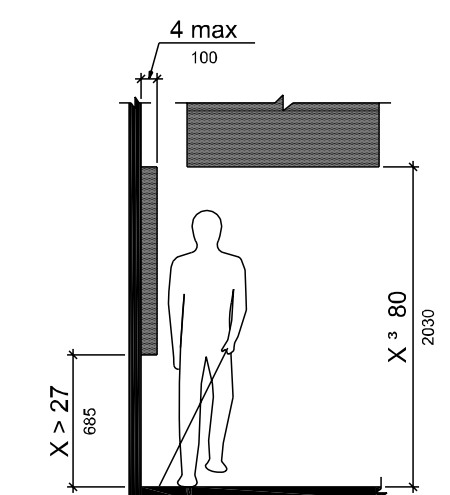
**Figure 306.3**  
Knee Clearance

Figure 306.3 Knee Clearance

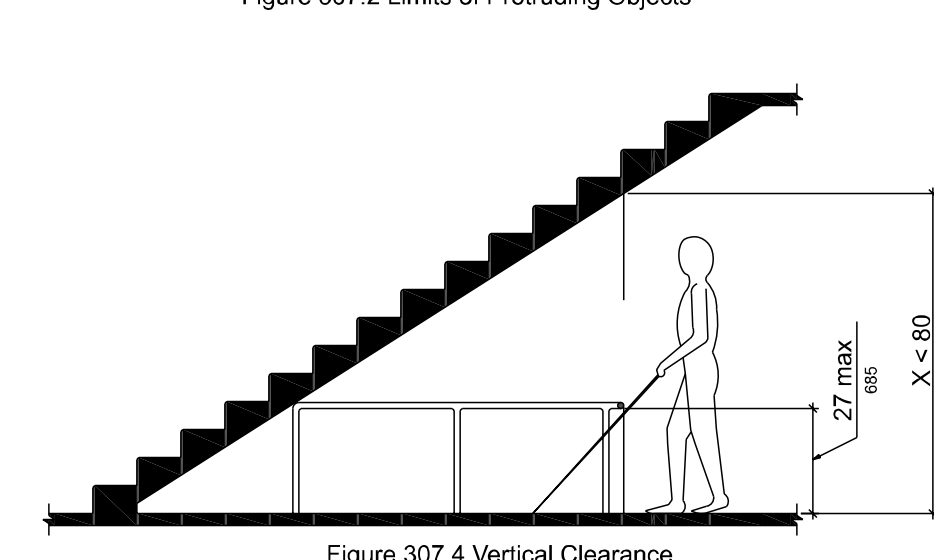
307 Protruding Objects

307.2 Protrusion Limits. Objects with leading edges more than 27 inches (685 mm) and not more than 80 inches (2030 mm) above the finish floor or ground shall protrude 4 inches (100 mm) maximum horizontally into the circulation path.

EXCEPTION: Handrails shall be permitted to protrude 4 1/2 inches (115 mm) maximum.



**Figure 307.2**  
Limits of Protruding Objects



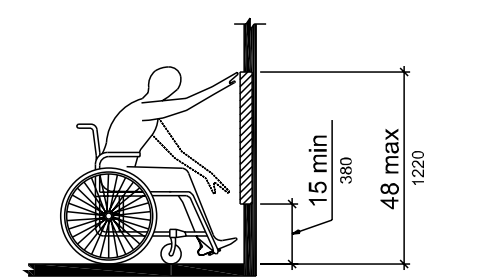
**Figure 307.4**  
Vertical Clearance

308 Reach Ranges

Children's Reach Ranges	High (maximum)	Low (minimum)
Forward or Side Reach		
Ages 3 and 4	36 in (915 mm)	20 in (510 mm)
Ages 5 through 8	40 in (1015 mm)	18 in (455 mm)
Ages 9 through 12	44 in (1120 mm)	16 in (405 mm)

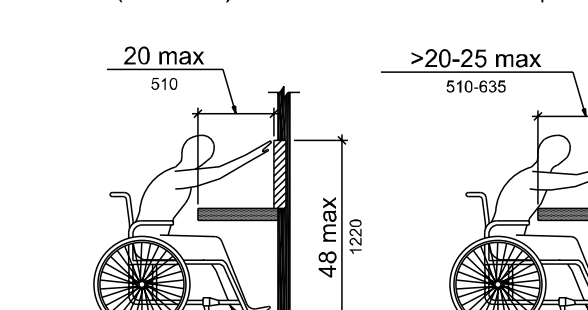
308.2 Forward Reach.

308.2.1 Unobstructed. Where a forward reach is unobstructed, the high forward reach shall be 48 inches (1220 mm) maximum and the low forward reach shall be 15 inches (380 mm) minimum above the finish floor or ground.



**Figure 308.2.1**  
Unobstructed Forward Reach

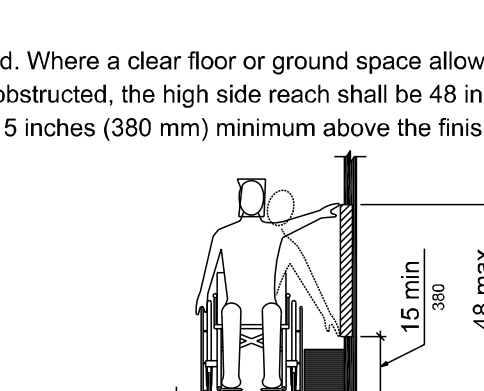
308.2.2 Obstructed High Reach. Where a high forward reach is over an obstruction, the clear floor space shall extend beneath the element for a distance not less than the required reach depth over the obstruction. The high forward reach shall be 48 inches (1220 mm) maximum where the reach depth is 20 inches (510 mm) maximum. Where the reach depth exceeds 20 inches (510 mm), the high forward reach shall be 44 inches (1120 mm) maximum and the reach depth shall be 25 inches (635 mm) maximum.



**Figure 308.2.2**  
Obstructed High Reach

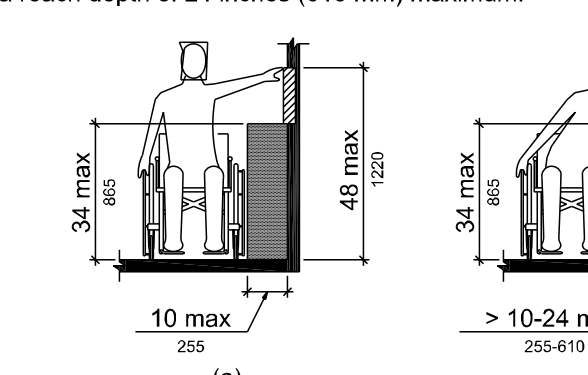
308.3 Side Reach.

308.3.1 Unobstructed. Where a clear floor or ground space allows a parallel approach to an element and the side reach is unobstructed, the high side reach shall be 48 inches (1220 mm) maximum and the low side reach shall be 15 inches (380 mm) minimum above the finish floor or ground.



**Figure 308.3.1**  
Unobstructed Side Reach

308.3.2 Obstructed High Side Reach. Where a clear floor or ground space allows a parallel approach to an element and the high side reach is over an obstruction, the height of the obstruction shall be 34 inches (865 mm) maximum and the depth of the obstruction shall be 24 inches (610 mm) maximum. The high side reach shall be 48 inches (1220 mm) maximum for a reach depth of 10 inches (255 mm) maximum. Where the reach depth exceeds 10 inches (255 mm), the high side reach shall be 46 inches (1170 mm) maximum for a reach depth of 24 inches (610 mm) maximum.



**Figure 308.3.2**  
Obstructed High Side Reach

**CHAPTER 4: ACCESSIBLE ROUTES**

402.2 Components. Accessible routes shall consist of one or more of the following components: walking surfaces with a running slope not steeper than 1:20, doorways, ramps, curb ramps excluding the flared sides, elevators, and platform lifts. All components of an accessible route shall comply with the applicable requirements of Chapter 4.

Advisory 402.2 Components. Walking surfaces must have running slopes not steeper than 1:20, see 403.3. Other components of accessible routes, such as ramps (405) and curb ramps (406), are permitted to be more steeply sloped.

403 Walking Surfaces

403.1 General. Walking surfaces that are a part of an accessible route shall comply with 403.

403.2 Floor or Ground Surface. Floor or ground surfaces shall comply with 302.

403.3 Slope. The running slope of walking surfaces shall not be steeper than 1:48. The cross slope of walking surfaces shall not be steeper than 1:48.

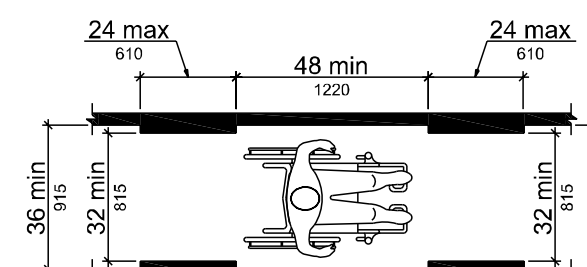
403.4 Changes in Level. Changes in level shall comply with 303.

403.5 Clearances. Walking surfaces shall provide clearances complying with 403.5.

EXCEPTION: Within employee work areas, clearances on common use circulation paths shall be permitted to be decreased by work area equipment provided that the decrease is essential to the function of the work being performed.

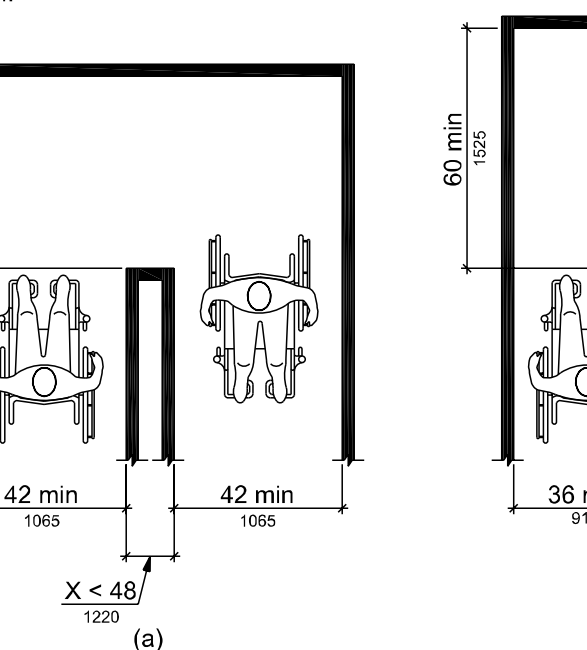
403.5.1 Clear Width. Except as provided in 403.5.2 and 403.5.3, the clear width of walking surfaces shall be 36 inches (915 mm) minimum.

EXCEPTION: The clear width shall be permitted to be reduced to 32 inches (815 mm) minimum for a length of 24 inches (610 mm) maximum provided that reduced width segments are separated by segments that are 48 inches (1220 mm) long minimum and 36 inches (915 mm) wide minimum.



**Figure 403.5.1**  
Clear Width of an Accessible Route

403.5.2 Clear Width at Turn. Where the accessible route makes a 180 degree turn around an element which is less than 48 inches (1220 mm) wide, clear width shall be 42 inches (1065 mm) minimum approaching the turn, 48 inches (1220 mm) minimum at the turn and 42 inches (1065 mm) minimum leaving the turn.

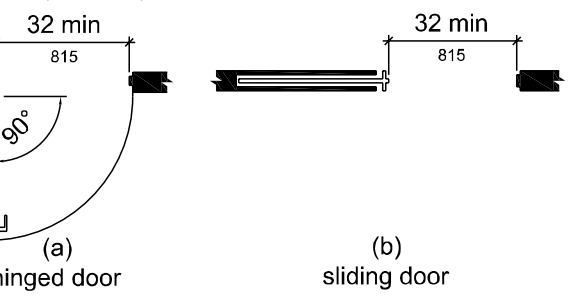


**Figure 403.5.2**  
Clear Width at Turn (Exception)

403.5.3 Passing Spaces. An accessible route with a clear width less than 60 inches (1525 mm) shall provide passing spaces at intervals of 200 feet (61 m) maximum.

404 Doors, Doorways, and Gates

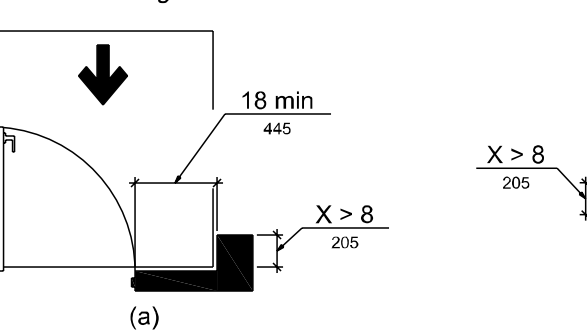
404.2.3 Clear Width. Door openings shall provide a clear width of 32 inches (815 mm) minimum. Clear openings of doorways with swinging doors shall be measured between the face of the door and the stop, with the door open 90 degrees. Openings more than 24 inches (610 mm) deep shall provide a clear opening of 36 inches (915 mm) minimum. There shall be no projections into the required clear opening width lower than 34 inches (865 mm) above the finish floor or ground. Projections into the clear opening width between 34 inches (865 mm) and 80 inches (2030 mm) above the finish floor or ground shall not exceed 4 inches (100 mm).



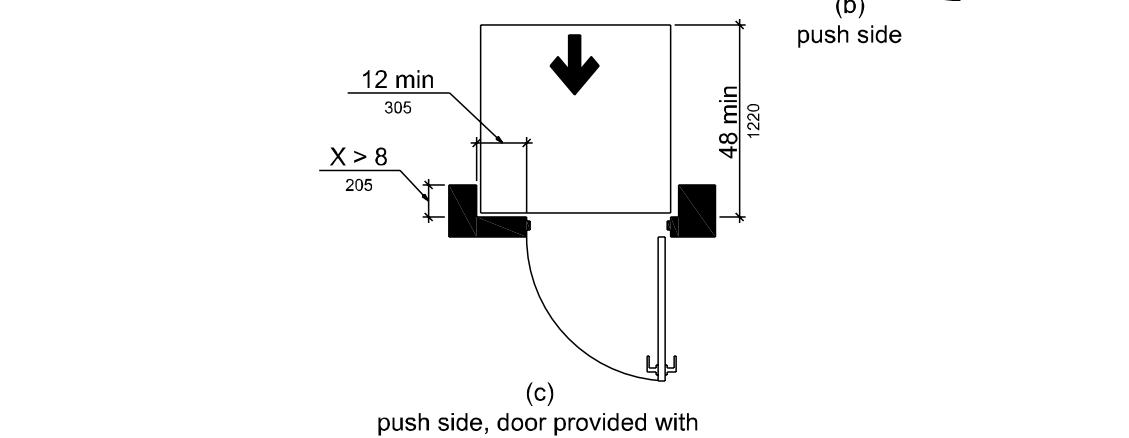
**Figure 404.2.3**  
Clear Width of Doorways

404.2.4 Maneuvering Clearances. Minimum maneuvering clearances at doors and gates shall comply with 404.2.4. Maneuvering clearances shall extend the full width of the doorway and the required latch side or hinge side clearance.

404.2.4.3 Recessed Doors and Gates. Maneuvering clearances for forward approach shall be provided when any obstruction within 18 inches (455 mm) of the latch side of a doorway projects more than 8 inches (205 mm) beyond the face of the door, measured perpendicular to the face of the door or gate.

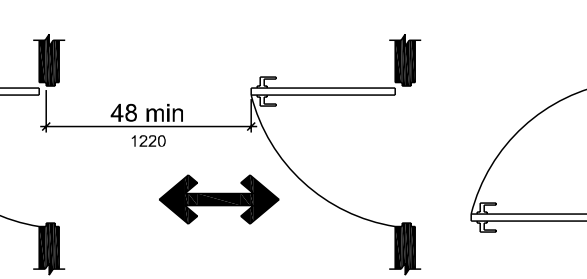


**Figure 404.2.4.3**  
Maneuvering Clearances at Recessed Doors and Gates

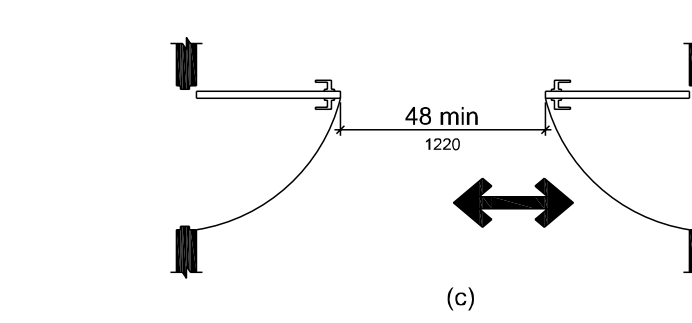


**Figure 404.2.4.3**  
Maneuvering Clearances at Recessed Doors and Gates

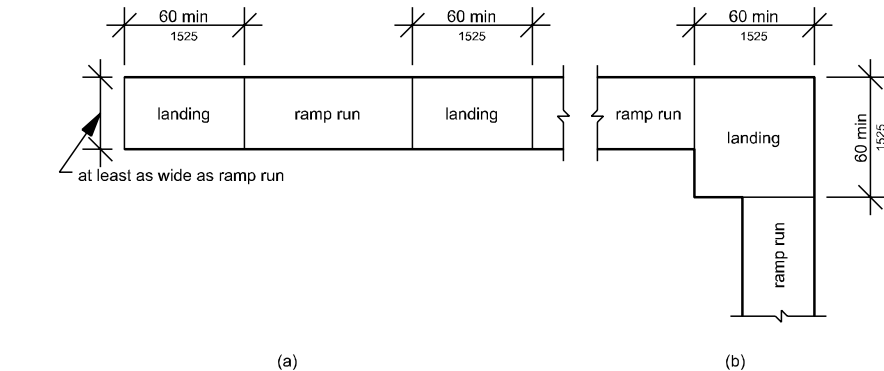
404.2.6 Doors in Series and Gates in Series. The distance between two hinged or pivoted doors in series and gates in series shall be 48 inches (1220 mm) minimum plus the width of doors or gates swinging into the space.



**Figure 404.2.6**  
Doors in Series and Gates in Series



**Figure 404.2.6**  
Doors in Series and Gates in Series



**Figure 405.7**  
Ramp Landings

405.7.1 Slope. Landings shall have slope not steeper than 1:48. Changes in level are not permitted.

405.7.2 Width. The landing clear width shall be at least as wide as the widest ramp run leading to the landing.

405.7.3 Length. The landing clear length shall be 60 inches (1525 mm) long minimum.

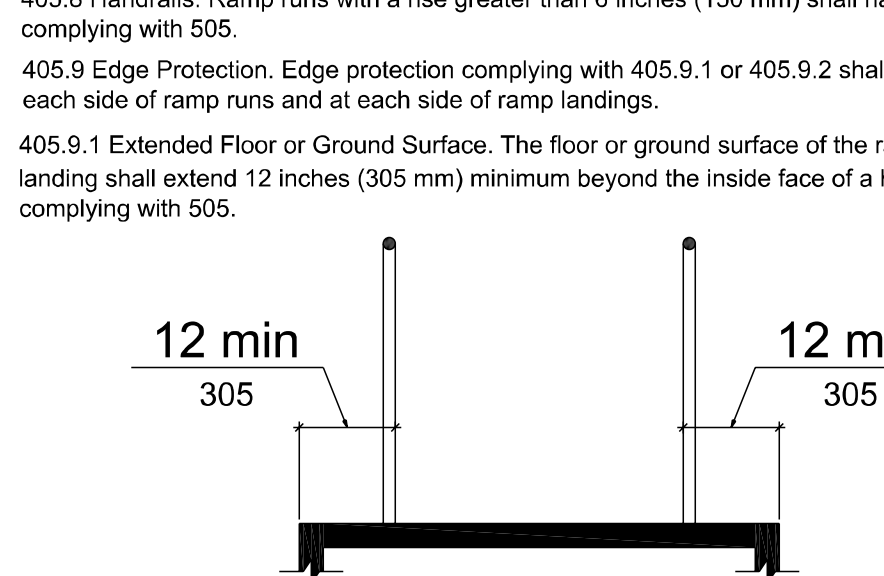
405.7.4 Change in Direction. Ramps that change direction between runs at landings shall have a clear landing 60 inches (1525 mm) minimum by 60 inches (1525 mm) minimum.

405.7.5 Doorways. Where doorways are located adjacent to a ramp landing, maneuvering clearances required by 404.2.4 and 404.3.2 shall be permitted to overlap the required landing

405.8 Handrails. Ramp runs with a rise greater than 6 inches (150 mm) shall have handrails complying with 505.

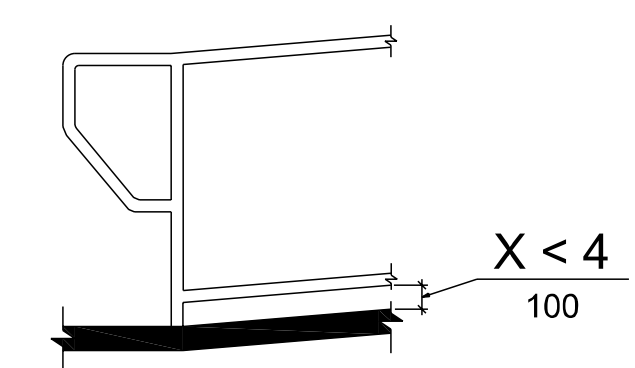
405.9 Edge Protection. Edge protection complying with 405.9.1 or 405.9.2 shall be provided on each side of ramp runs and at each side of ramp landings.

405.9.1 Extended Floor or Ground Surface. The floor or ground surface of the ramp run or landing shall extend 12 inches (305 mm) minimum beyond the inside face of a handrail complying with 505.



**Figure 405.9.1**  
Extended Floor or Ground Surface Edge Protection

405.9.2 Curb or Barrier. A curb or barrier shall be provided that prevents the passage of a 4 inch (100 mm) diameter sphere, where any portion of the sphere is within 4 inches (100 mm) of the finish floor or ground surface.

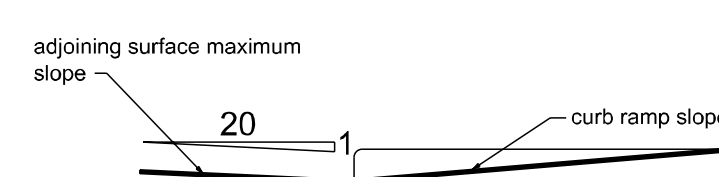


**Figure 405.9.2**  
Curb or Barrier Edge Protection

406 Curb Ramps

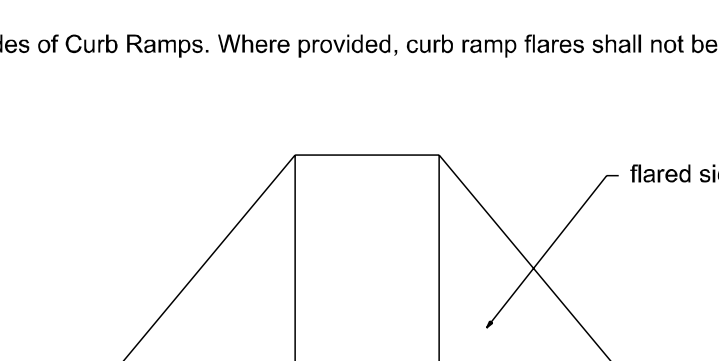
406.1 General. Curb ramps on accessible routes shall comply with 406, 405.2 through 405.5, and 405.10.

406.2 Counter Slope. Counter slopes of adjoining gutters and road surfaces immediately adjacent to the curb ramp shall not be steeper than 1:20. The adjacent surfaces at transitions at curb ramps to walks, gutters, and streets shall be at the same level.



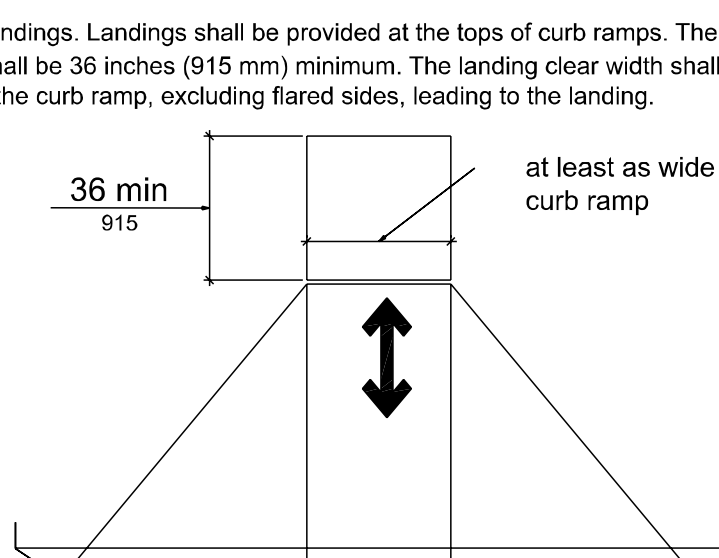
**Figure 406.2**  
Counter Slope of Surfaces Adjacent to Curb Ramps

406.3 Sides of Curb Ramps. Where provided, curb ramp flares shall not be steeper than 1:10.



**Figure 406.3**  
Sides of Curb Ramps

406.4 Landings. Landings shall be provided at the tops of curb ramps. The landing clear length shall be 36 inches (915 mm) minimum. The landing clear width shall be at least as wide as the curb ramp, excluding flared sides, leading to the landing.



**Figure 406.4**  
Landings at the Top of Curb Ramps

406.5 Location. Curb ramps and the flared sides of curb ramps shall be located so that they do not project into vehicular traffic lanes, parking spaces, or parking access aisles. Curb ramps at marked crossings shall be wholly contained within the markings, excluding any flared sides.

504 Stairways

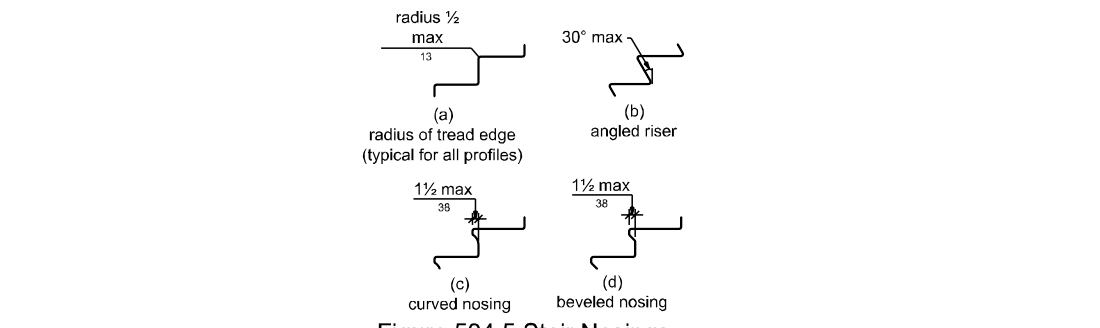
504.1 General. Stairs that are part of the means of egress is required to comply with 504

504.2 Treads and Risers. All steps on a flight of stairs shall have uniform riser heights and uniform tread depths. Riser shall be 4 inches (100 mm) high minimum and 7 inches (180 mm) high maximum. Treads shall be 11 inches (280 mm) deep minimum.

504.3 Open Risers. Open risers are not permitted.

504.4 Tread Surface. Stair treads shall comply with 302. Changes in level are not permitted.

504.5 Nosings. The radius of curvature at the leading edge of the tread shall be 1/2 inch (13 mm) maximum. Nosings that project beyond risers shall have the underside of the leading edge curved or beveled. Risers shall be permitted to slope under the tread at an angle of 30 degrees maximum from vertical. The permitted projection of the nosing shall extend 1 1/2 inches (38 mm) maximum over the tread below.



**Figure 504.5**  
Stair Nosings

504.6 Handrails. Stairs shall have handrails complying with 505.

504.7 Wet Conditions. Stair treads and landings subject to wet conditions shall be designed to prevent the accumulation of water.

505 Handrails

505.1 General. Handrails provided along walking surfaces complying with 403, required at ramps complying with 405, and required at stairs complying with 504 shall comply with 505.

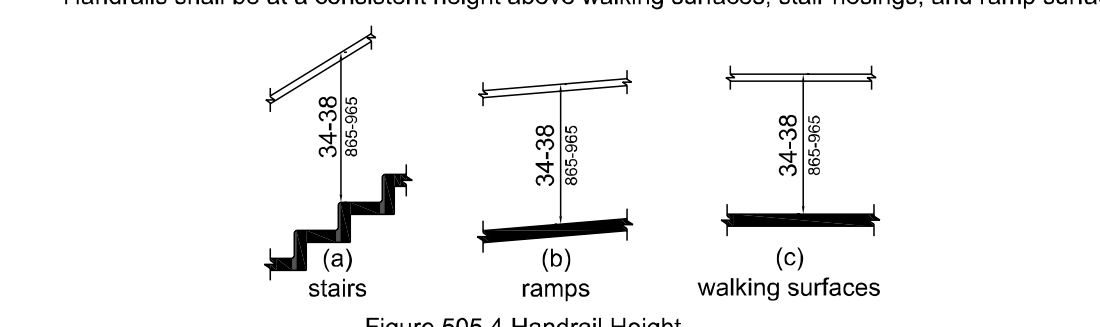
Advisory 505.1 General. Handrails are required on ramp runs with a rise greater than 6 inches (150 mm) (see 405.8) and on certain stairways (see 504). Handrails are not required on walking surfaces with running slopes less than 1:20. However, handrails are required to comply with 505 when they are provided on walking surfaces with running slopes less than 1:20 (see 403.6).

Sections 505.2, 505.3, and 505.10 do not apply to handrails provided on walking surfaces with running slopes less than 1:20 as these sections only reference requirements for ramps and stairs.

505.2 Where Required. Handrails shall be provided on both sides of stairs and ramps.

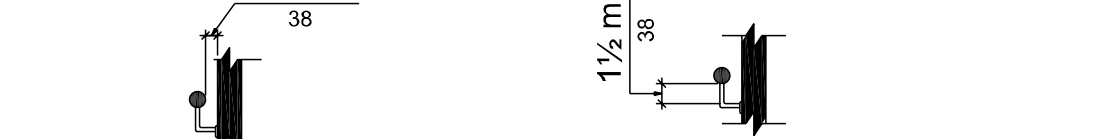
505.3 Continuity. Handrails shall be continuous within the full length of each stair flight or ramp run. Inside handrails on switchback or dogleg stairs and ramps shall be continuous between flights or runs.

505.4 Height. Top of gripping surfaces of handrails shall be 34 inches (865 mm) minimum and 38 inches (965 mm) maximum vertically above walking surfaces, stair nosings, and ramp surfaces. Handrails shall be at a consistent height above walking surfaces, stair nosings, and ramp surfaces.



**Figure 505.4**  
Handrail Height

505.5 Clearance. Clearance between handrail gripping surfaces and adjacent surfaces shall be 1 1/2 inches (38 mm) minimum.

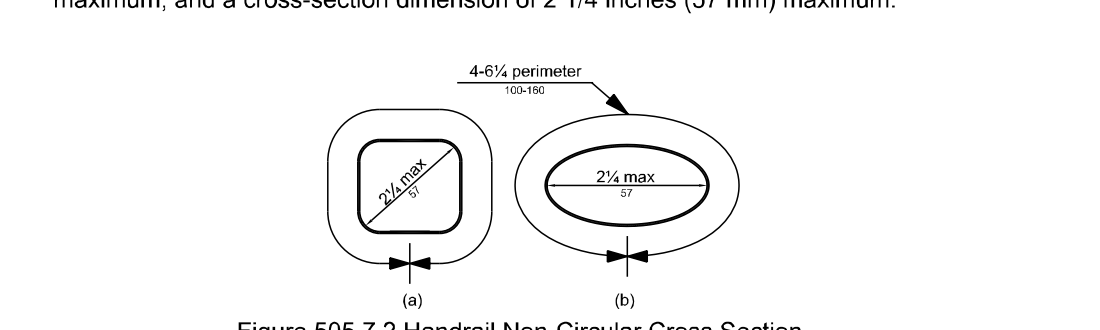


**Figure 505.5**  
Handrail Clearance

505.6 Gripping Surface. Handrail gripping surfaces shall be continuous along their length and shall not be obstructed along their tops or sides. The bottoms of handrail gripping surfaces shall not be obstructed for more than 20 percent of their length. Where provided, horizontal projections shall occur 1 1/2 inches (38 mm) minimum below the bottom of the handrail gripping surface.

505.7.1 Circular Cross Section. Handrail gripping surfaces with a circular cross section shall have an outside diameter of 1 1/4 inches (32 mm) minimum and 2 inches (51 mm) maximum.

505.7.2 Non-Circular Cross Section. Handrail gripping surfaces with a non-circular cross section shall have a perimeter dimension of 4 inches (100 mm) minimum and 6 1/4 inches (160 mm) maximum, and a cross-section dimension of 2 1/4 inches (57 mm) maximum.



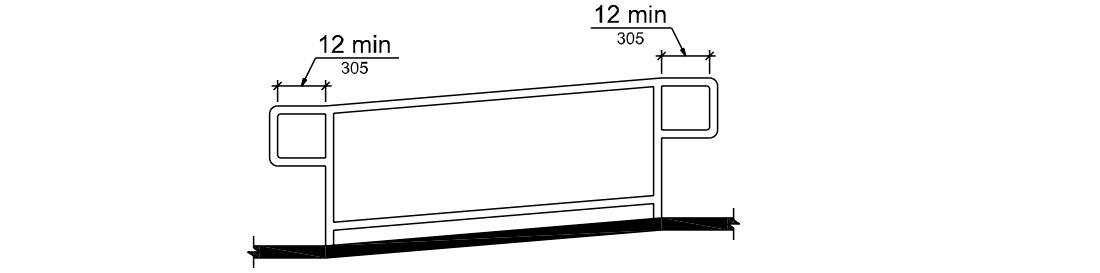
**Figure 505.7.2**  
Handrail Non-Circular Cross Section

505.8 Surfaces. Handrail gripping surfaces and any surfaces adjacent to them shall be free of sharp or abrasive elements and shall have rounded edges.

505.9 Fittings. Handrails shall not rotate within their fittings.

505.10 Handrail Extensions. Handrail gripping surfaces shall extend beyond and in the same direction of stair flights and ramp runs in accordance with 505.10.

505.10.1 Top and Bottom Extension at Ramps. Ramp handrails shall extend horizontally above the landing for 12 inches (305 mm) minimum beyond the top and bottom of ramp runs. Extensions shall return to a wall, guard, or the landing surface, or shall be continuous to the handrail of an adjacent ramp run.



**Figure 505.10.1**  
Top and Bottom Handrail Extension at Ramps

505.10.2 Top Extension at Stairs. At the top of a stair flight, handrails shall extend horizontally above the landing for 12 inches (305 mm) minimum beginning directly above the first riser nosing. Extensions shall return to a wall, guard, or the landing surface, or shall be continuous to the handrail of an adjacent stair flight.



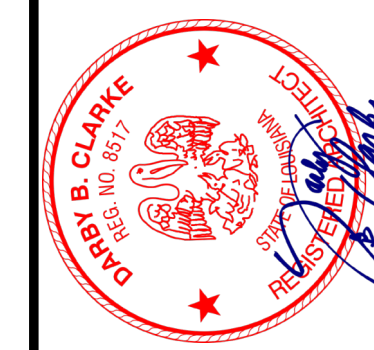
**Figure 505.10.2**  
Top Handrail Extension at Stairs

505.10.3 Bottom Handrail Extension at Stairs. At the bottom of a stair flight, handrails shall extend at the slope of the stair flight for a horizontal distance at least equal to one tread depth beyond the last riser nosing. Extension shall return to a wall, guard, or the landing surface, or shall be continuous to the handrail of an adjacent stair flight.

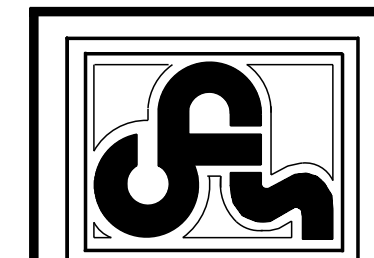


**Figure 505.10.3**  
Bottom Handrail Extension at Stairs

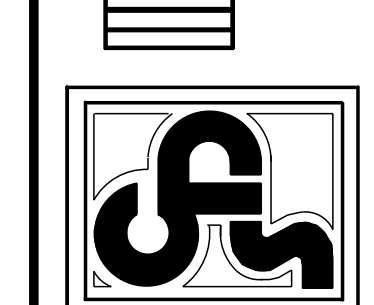
**NOTE:**  
ALTHOUGH EVERY EFFORT HAS BEEN MADE IN THE DRAWING, THE ARCHITECT ASSUMES NO LIABILITY FOR CHECKING THE PLANS FOR CONSTRUCTION ERRORS BEFORE CONSTRUCTION BEGINS.



**DARBY CLARKE**  
ARCHITECT, INC.  
1537 THIRD STREET  
SLIDELL, LA 70458  
WWW.CLARKESERVICE.COM (985) 641-0531



**CLARKE'S DESIGN SERVICE, LLC.**  
1537 THIRD STREET  
SLIDELL, LA 70458  
WWW.CLARKESERVICE.COM (985) 641-0531



**LOUISIANA CORNEA SPECIALIST**  
2121 CAUSEWAY BLVD.  
MANDEVILLE, LA 70471  
ST. TAMMANY PARISH, LA.

**CODE:**  
7352  
**DATE:**  
10-06-25

**DESCRIPTION:**  
HANDICAP

CHAPTER 6: PLUMBING ELEMENTS AND FACILITIES

602 Drinking Fountains  
 602.2 Clear Floor Space. Units shall have a clear floor or ground space complying with 305 positioned for a forward approach and centered on the unit. Knee and toe clearance complying with 306 shall be provided.  
 EXCEPTION: A parallel approach complying with 305 shall be permitted at units for children's use where the spout is 30 inches (760 mm) maximum above the finish floor or ground and is 3 1/2 inches (90 mm) maximum from the front edge of the unit, including bumpers.

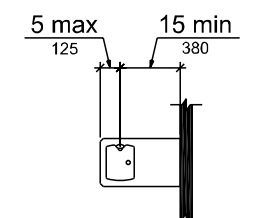


Figure 602.5 Drinking Fountain Spout Location

602.6 Water Flow. The spout shall provide a flow of water 4 inches (100 mm) high minimum and shall be located 5 inches (125 mm) maximum from the front of the unit. The angle of the water stream shall be measured horizontally relative to the front face of the unit. Where spouts are located less than 3 inches (75 mm) of the front of the unit, the angle of the water stream shall be 30 degrees maximum. Where spouts are located between 3 inches (75 mm) and 5 inches (125 mm) maximum from the front of the unit, the angle of the water stream shall be 15 degrees maximum.

602.7 Drinking Fountains for Standing Persons. Spout outlets of drinking fountains for standing persons shall be 38 inches (965 mm) minimum and 43 inches (1090 mm) maximum above the finish floor or ground.

603 Toilet and Bathing Rooms  
 603.2 Clearances. Clearances shall comply with 603.2.  
 603.2.1 Turning Space. Turning space complying with 304 shall be provided within the room.  
 603.2.2 Overlap. Required clear floor spaces, clearance at fixtures, and turning space shall be permitted to overlap.

603.2.3 Door Swing. Doors shall not swing into the clear floor space or clearance required for any fixture. Doors shall be permitted to swing into the required turning space.

603.3 Mirrors. Mirrors located above lavatories or countertops shall be installed with the bottom edge of the reflecting surface 40 inches (1015 mm) maximum above the finish floor or ground. Mirrors not located above lavatories or countertops shall be installed with the bottom edge of the reflecting surface 35 inches (890 mm) maximum above the finish floor or ground.

603.4 Coat Hooks and Shelves. Coat hooks shall be located within one of the reach ranges specified in 308. Shelves shall be located 40 inches (1015 mm) minimum and 48 inches (1220 mm) maximum above the finish floor.

604 Water Closets and Toilet Compartments  
 604.2 Location. The water closet shall be positioned with a wall or partition to the rear and to one side. The centerline of the water closet shall be 16 inches (405 mm) minimum to 18 inches (455 mm) maximum from the side wall or partition, except that the water closet shall be 17 inches (430 mm) minimum and 19 inches (485 mm) maximum from the side wall or partition in the ambulatory accessible toilet compartment specified in 604.8.2. Water closets shall be arranged for a left-hand or right-hand approach.

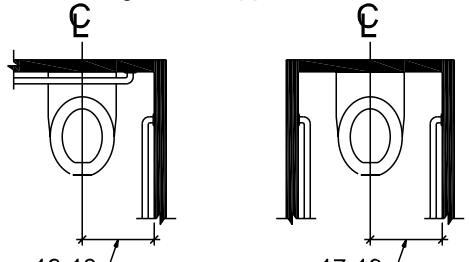


Figure 604.2 Water Closet Location

604.3.1 Size. Clearance around a water closet shall be 60 inches (1525 mm) minimum measured perpendicular from the side wall and 56 inches (1420 mm) minimum measured perpendicular from the rear wall.

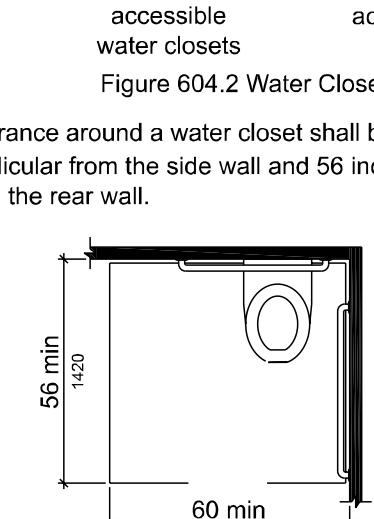


Figure 604.3.1 Size of Clearance at Water Closets

604.3.2 Overlap. The required clearance around the water closet shall be permitted to overlap the water closet, associated grab bars, dispensers, sanitary napkin disposal units, coat hooks, shelves, accessible routes, clear floor space and clearances required at other fixtures, and the turning space. No other fixtures or obstructions shall be located within the required water closet clearance.

604.4 Seats. The seat height of a water closet above the finish floor shall be 17 inches (430 mm) minimum and 19 inches (485 mm) maximum measured to the top of the seat. Seats shall not be sprung to return to a lifted position.

604.5 Grab Bars. Grab bars for water closets shall comply with 609. Grab bars shall be provided on the side wall closest to the water closet and on the rear wall.

604.5.1 Side Wall. The side wall grab bar shall be 42 inches (1065 mm) long minimum, located 12 inches (305 mm) maximum from the rear wall and extending 54 inches (1370 mm) minimum from the rear wall.

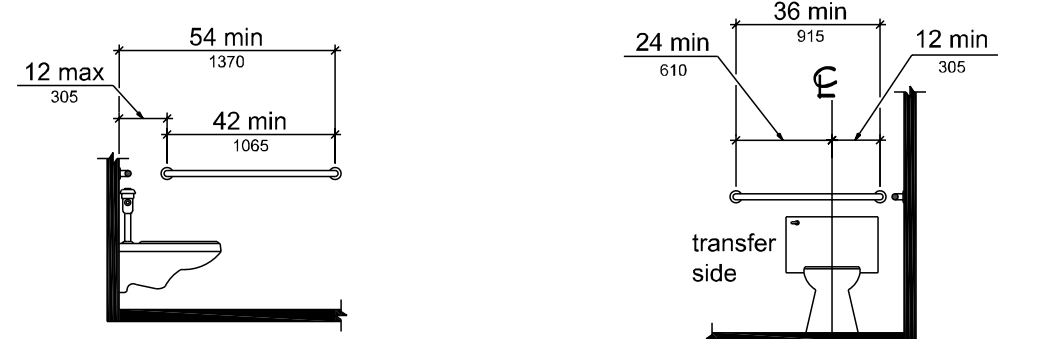


Figure 604.5.1 Side Wall Grab Bar at Water Closets

604.5.2 Rear Wall. The rear wall grab bar shall be 36 inches (915 mm) long minimum and extend from the centerline of the water closet 12 inches (305 mm) minimum on one side and 24 inches (610 mm) minimum on the other side.

604.6 Flush Controls. Flush controls shall be hand operated or automatic. Hand operated flush controls shall comply with 309. Flush controls shall be located on the open side of the water closet except in ambulatory accessible compartments complying with 604.8.2.

604.7 Dispensers. Toilet paper dispensers shall comply with 309.4 and shall be 7 inches (180 mm) minimum and 9 inches (230 mm) maximum in front of the water closet measured to the centerline of the dispenser. The outlet of the dispenser shall be 15 inches (380 mm) minimum and 48 inches (1220 mm) maximum above the finish floor and shall not be located behind grab bars. Dispensers shall not be of a type that controls delivery or that does not allow continuous paper flow.

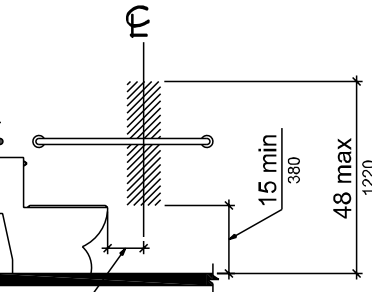


Figure 604.7 Dispenser Outlet Location

604.8 Toilet Compartments. Wheelchair accessible toilet compartments shall meet the requirements of 604.8.1 and 604.8.3. Compartments containing more than one plumbing fixture shall comply with 603. Ambulatory accessible compartments shall comply with 604.8.2 and 604.8.3.

604.8.1 Wheelchair Accessible Compartments. Wheelchair accessible compartments shall comply with 604.8.1.

604.8.1.1 Size. Wheelchair accessible compartments shall be 60 inches (1525 mm) wide minimum measured perpendicular to the side wall, and 56 inches (1420 mm) deep minimum for wall hung water closets and 59 inches (1500 mm) deep minimum for floor mounted water closets measured perpendicular to the rear wall. Wheelchair accessible compartments for children's use shall be 60 inches (1525 mm) wide minimum measured perpendicular to the side wall, and 59 inches (1500 mm) deep minimum for wall hung and floor mounted water closets measured perpendicular to the rear wall.

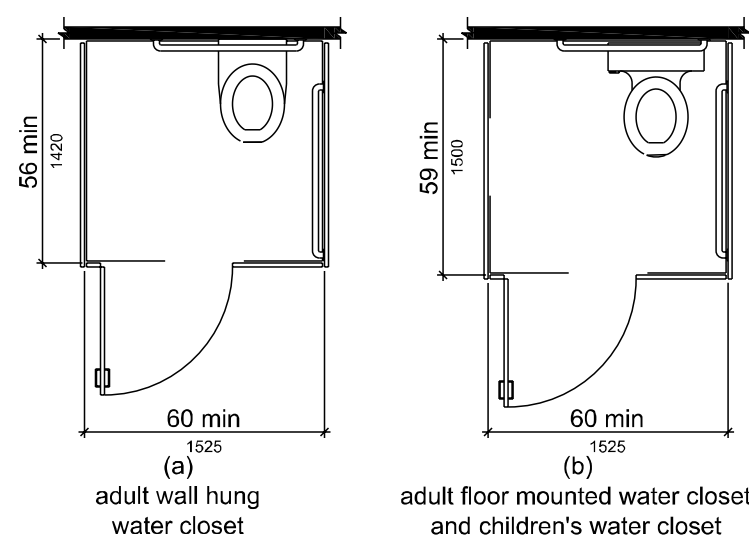


Figure 604.8.1.1 Size of Wheelchair Accessible Toilet Compartment

604.8.1.2 Doors. Toilet compartment doors, including door hardware, shall comply with 404 except that if the approach is to the latch side of the compartment door, clearance between the door side of the compartment and any obstruction shall be 42 inches (1065 mm) minimum. Doors shall be located in the front partition or in the side wall or partition farthest from the water closet. Where located in the front partition, the door opening shall be 4 inches (100 mm) maximum from the side wall or partition farthest from the water closet. Where located in the side wall or partition, the door opening shall be 4 inches (100 mm) maximum from the front partition. The door shall be self-closing. A door pull complying with 404.2.7 shall be placed on both sides of the door near the latch. Toilet compartment doors shall not swing into the minimum required compartment area.

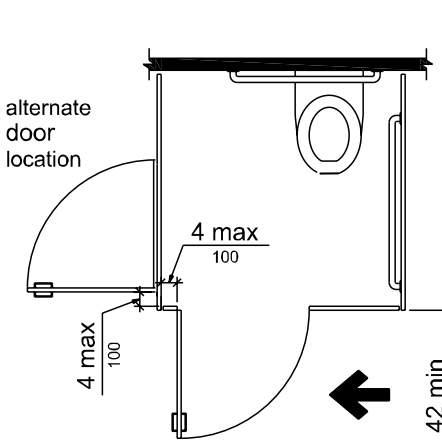


Figure 604.8.1.2 Wheelchair Accessible Toilet Compartment Doors

604.8.1.3 Approach. Compartments shall be arranged for left-hand or right-hand approach to the water closet.

604.8.1.4 Toe Clearance. The front partition and at least one side partition shall provide a toe clearance of 9 inches (230 mm) minimum above the finish floor and 6 inches (150 mm) deep minimum beyond the compartment-side face of the partition, exclusive of partition support members. Compartments for children's use shall provide a toe clearance of 12 inches (305 mm) minimum above the finish floor.

EXCEPTION: Toe clearance at the front partition is not required in a compartment greater than 62 inches (1575 mm) deep with a wall-hung water closet or 65 inches (1650 mm) deep with a floor-mounted water closet. Toe clearance at the side partition is not required in a compartment greater than 66 inches (1675 mm) wide. Toe clearance at the front partition is not required in a compartment for children's use that is greater than 65 inches (1650 mm) deep.

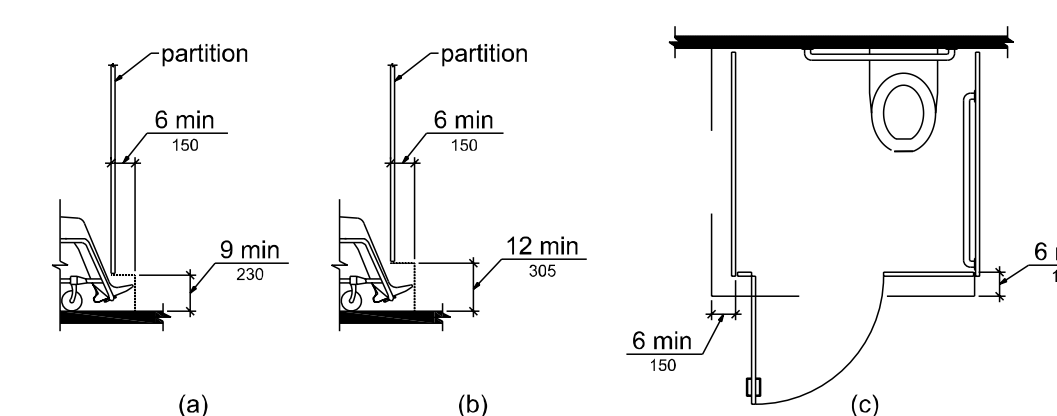


Figure 604.8.1.4 Wheelchair Accessible Toilet Compartment Toe Clearance

604.8.1.5 Grab Bars. Grab bars shall comply with 609. A side-wall grab bar complying with 604.5.1 shall be provided and shall be located on the wall closest to the water closet. In addition, a rear-wall grab bar complying with 604.5.2 shall be provided.

604.8.2 Ambulatory Accessible Compartments. Ambulatory accessible compartments shall comply with 604.8.2.

604.8.2.1 Size. Ambulatory accessible compartments shall have a depth of 60 inches (1525 mm) minimum and a width of 35 inches (890 mm) minimum and 37 inches (940 mm) maximum.

604.8.2.2 Doors. Toilet compartment doors, including door hardware, shall comply with 404, except that if the approach is to the latch side of the compartment door, clearance between the door side of the compartment and any obstruction shall be 42 inches (1065 mm) minimum. The door shall be self-closing. A door pull complying with 404.2.7 shall be placed on both sides of the door near the latch. Toilet compartment doors shall not swing into the minimum required compartment area.

604.8.2.3 Grab Bars. Grab bars shall comply with 609. A side-wall grab bar complying with 604.5.1 shall be provided on both sides of the compartment.

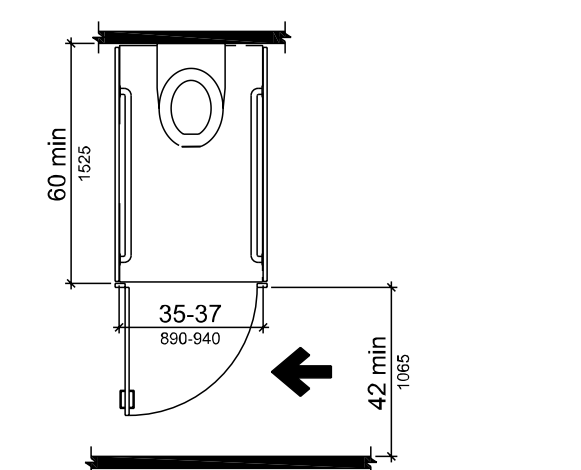


Figure 604.8.2 Ambulatory Accessible Toilet Compartment

604.8.3 Coat Hooks and Shelves. Coat hooks shall be located within one of the reach ranges specified in 308. Shelves shall be located 40 inches (1015 mm) minimum and 48 inches (1220 mm) maximum above the finish floor.

604.9 Water Closets and Toilet Compartments for Children's Use. Water closets and toilet compartments for children's use shall comply with 604.9.

604.9.1 Location. The water closet shall be located with a wall or partition to the rear and to one side. The centerline of the water closet shall be 12 inches (305 mm) minimum and 18 inches (455 mm) maximum from the side wall or partition, except that the water closet shall be 17 inches (430 mm) minimum and 19 inches (485 mm) maximum from the side wall or partition in the ambulatory accessible toilet compartment specified in 604.8.2. Compartments shall be arranged for left-hand or right-hand approach to the water closet.

604.9.2 Clearance. Clearance around a water closet shall comply with 604.3.

604.9.3 Height. The height of water closets shall be 11 inches (280 mm) minimum and 17 inches (430 mm) maximum measured to the top of the seat. Seats shall not be sprung to return to a lifted position.

604.9.4 Grab Bars. Grab bars for water closets shall comply with 604.5.

604.9.5 Flush Controls. Flush controls shall be hand operated or automatic. Hand operated flush controls shall comply with 309.2 and 309.4 and shall be installed 36 inches (915 mm) maximum above the finish floor. Flush controls shall be located on the open side of the water closet except in ambulatory accessible compartments complying with 604.8.2.

604.9.6 Dispensers. Toilet paper dispensers shall comply with 309.4 and shall be 7 inches (180 mm) minimum and 9 inches (230 mm) maximum in front of the water closet measured to the centerline of the dispenser. The outlet of the dispenser shall be 14 inches (355 mm) minimum and 19 inches (485 mm) maximum above the finish floor. There shall be a clearance of 1 1/2 inches (38 mm) minimum below the grab bar. Dispensers shall not be of a type that controls delivery or that does not allow continuous paper flow.

604.9.7 Toilet Compartments. Toilet compartments shall comply with 604.8.

605 Urinals

605.2 Height and Depth. Urinals shall be the stall-type or the wall-hung type with the rim 17 inches (430 mm) maximum above the finish floor or ground. Urinals shall be 13 1/2 inches (345 mm) deep minimum measured from the outer face of the urinal rim to the back of the fixture.

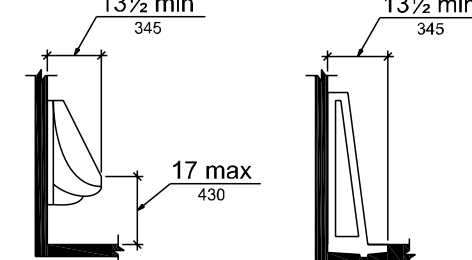


Figure 605.2 Height and Depth of Urinals

605.3 Clear Floor Space. A clear floor or ground space complying with 305 positioned for forward approach shall be provided.

605.4 Flush Controls. Flush controls shall be hand operated or automatic. Hand operated flush controls shall comply with 309.

606 Lavatories and Sinks

606.2 Clear Floor Space. A clear floor space complying with 305, positioned for a forward approach, and knee and toe clearance complying with 306 shall be provided.

606.3 Height. Lavatories and sinks shall be installed with the front of the higher of the rim or counter surface 34 inches (865 mm) maximum above the finish floor or ground.

606.4 Faucets. Controls for faucets shall comply with 309. Hand-operated metering faucets shall remain open for 10 seconds minimum.

606.5 Exposed Pipes and Surfaces. Water supply and drain pipes under lavatories and sinks shall be insulated or otherwise configured to protect against contact. There shall be no sharp or abrasive surfaces under lavatories and sinks.

607 Bathtubs

607.2 Clearance. Clearance in front of bathtubs shall extend the length of the bathtub and shall be 30 inches (760 mm) wide minimum. A lavatory complying with 606 shall be permitted at the control end of the clearance. Where a permanent seat is provided at the head end of the bathtub, the clearance shall extend 12 inches (305 mm) minimum beyond the wall at the head end of the bathtub.

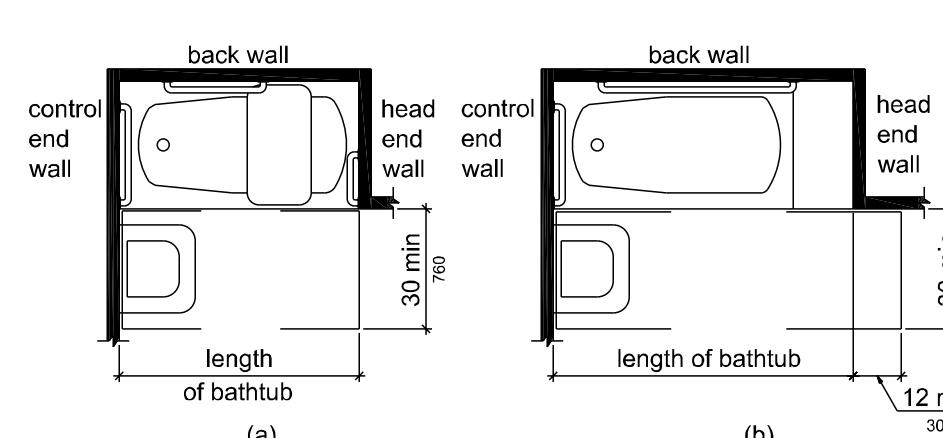


Figure 607.2 Clearance for Bathtubs

607.3 Seat. A permanent seat at the head end of the bathtub or a removable in-tub seat shall be provided. Seats shall comply with 610.

607.4 Grab Bars. Grab bars for bathtubs shall comply with 609 and shall be provided in accordance with 607.4.1 or 607.4.2.

607.4.1 Bathtubs With Permanent Seats. For bathtubs with permanent seats, grab bars shall be provided in accordance with 607.4.1.

607.4.1.1 Back Wall. Two grab bars shall be installed on the back wall, one located in accordance with 609.4 and the other located 8 inches (205 mm) minimum and 10 inches (255 mm) maximum above the rim of the bathtub. Each grab bar shall be installed 15 inches (380 mm) maximum from the head end wall and 12 inches (305 mm) maximum from the control end wall.

607.4.1.2 Control End Wall. A grab bar 24 inches (610 mm) long minimum shall be installed on the control end wall at the front edge of the bathtub.

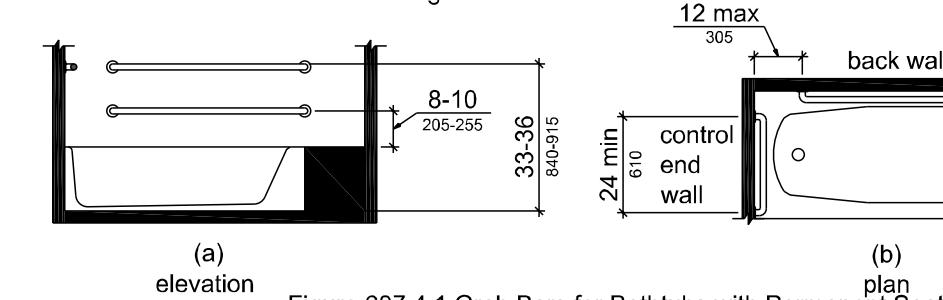


Figure 607.4.1 Grab Bars for Bathtubs with Permanent Seats

607.4.2 Bathtubs Without Permanent Seats. For bathtubs without permanent seats, grab bars shall comply with 607.4.2.

607.4.2.1 Back Wall. Two grab bars shall be installed on the back wall, one located in accordance with 609.4 and other located 8 inches (205 mm) minimum and 10 inches (255 mm) maximum above the rim of the bathtub. Each grab bar shall be 24 inches (610 mm) long minimum and shall be installed 24 inches (610 mm) maximum from the head end wall and 12 inches (305 mm) maximum from the control end wall.

607.4.2.2 Control End Wall. A grab bar 24 inches (610 mm) long minimum shall be installed on the control end wall at the front edge of the bathtub.

607.4.2.3 Head End Wall. A grab bar 12 inches (305 mm) long minimum shall be installed on the head end wall at the front edge of the bathtub.

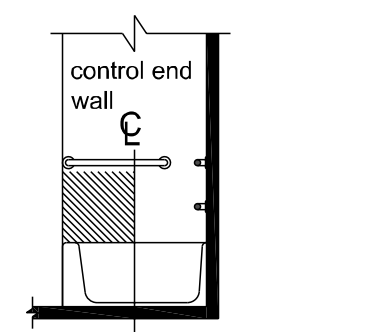


Figure 607.5 Bathtub Control Location

607.5 Controls. Controls, other than drain stoppers, shall be located on an end wall. Controls shall be between the bathtub rim and grab bar, and between the open side of the bathtub and the centerline of the width of the bathtub. Controls shall comply with 309.4.

607.6 Shower Spray Unit and Water. A shower spray unit with a hose 59 inches (1500 mm) long minimum that can be used both as a fixed-position shower head and as a hand-held shower shall be provided. The shower spray unit shall have an on/off control with a non-positive shut-off. If an adjustable-height shower head on a vertical bar is used, the bar shall be installed so as not to obstruct the use of grab bars. Bathtub shower spray units shall deliver water that is 120°F (49°C) maximum.

607.7 Bathtub Enclosures. Enclosures for bathtubs shall not obstruct controls, faucets, shower and spray units or obstruct transfer from wheelchairs onto bathtub seats or into bathtubs. Enclosures on bathtubs shall not have tracks installed on the rim of the open face of the bathtub.

608 Shower Compartments

608.2 Size and Clearances for Shower Compartments. Shower compartments shall have sizes and clearances complying with 608.2.

608.2.1 Transfer Type Shower Compartments. Transfer type shower compartments shall be 36 inches (915 mm) by 36 inches (915 mm) clear inside dimensions measured at the center points of opposing sides and shall have a 36 inch (915 mm) wide minimum entry on the face of the shower compartment. Clearance of 36 inches (915 mm) wide minimum by 48 inches (1220 mm) long minimum measured from the control wall shall be provided.

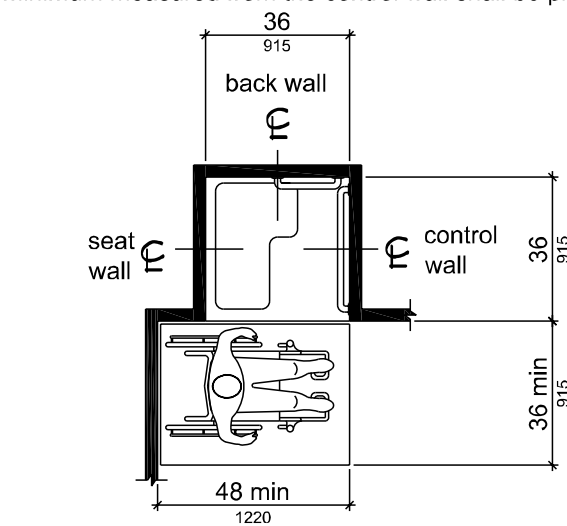


Figure 608.2.1 Transfer Type Shower Compartment Size and Clearance

608.2.2 Standard Roll-In Type Shower Compartments. Standard roll-in type shower compartments shall be 30 inches (760 mm) wide minimum by 60 inches (1525 mm) deep minimum clear inside dimensions measured at center points of opposing sides and shall have a 60 inches (1525 mm) wide minimum entry on the face of the shower compartment.

608.2.2.1 Clearance. A 30 inch (760 mm) wide minimum by 60 inch (1525 mm) long minimum clearance shall be provided adjacent to the open face of the shower compartment.

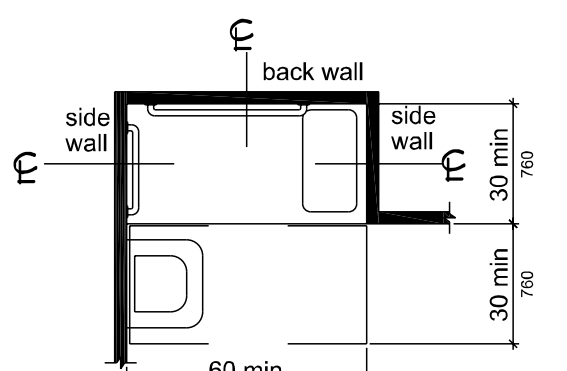


Figure 608.2.2 Standard Roll-In Type Shower Compartment Size and Clearance

608.2.3 Alternate Roll-In Type Shower Compartments. Alternate roll-in type shower compartments shall be 36 inches (915 mm) wide and 60 inches (1525 mm) deep minimum clear inside dimensions measured at center points of opposing sides. A 36 inch (915 mm) wide minimum entry shall be provided at one end of the long side of the compartment.

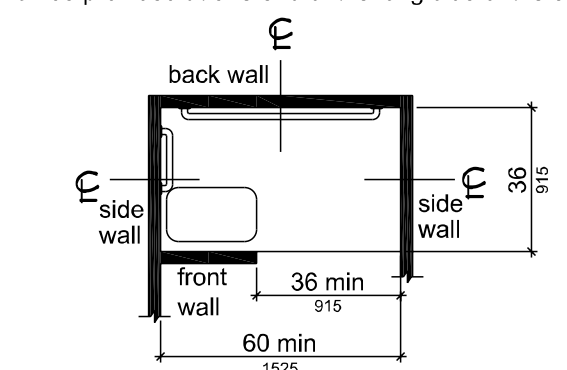


Figure 608.2.3 Alternate Roll-In Type Shower Compartment Size and Clearance

608.3 Grab Bars. Grab bars shall comply with 609 and shall be provided in accordance with 608.3. Where multiple grab bars are used, required, transfer type shower compartments, thresholds 1/2 inch (13 mm) high maximum shall be beveled, rounded, or vertical.

608.3.1 Transfer Type Shower Compartments. In transfer type compartments, grab bars shall be provided across the control wall and back wall to a point 18 inches (455 mm) from the control wall.

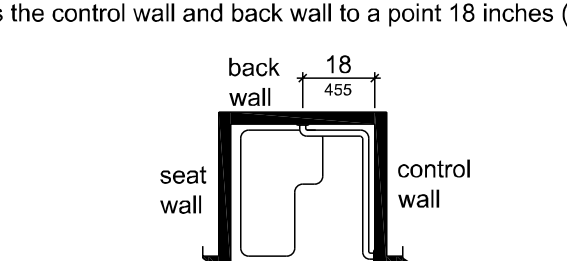


Figure 608.3.1 Grab Bars for Transfer Type Showers

608.3.2 Standard Roll-In Type Shower Compartments. Where a seat is provided in standard roll-in type shower compartments, grab bars shall be provided on the back wall and the side wall opposite the seat. Grab bars shall not be provided above the seat. Where a seat is not provided in standard roll-in type shower compartments, grab bars shall be provided on three walls. Grab bars shall be installed 6 inches (150 mm) maximum from adjacent walls.

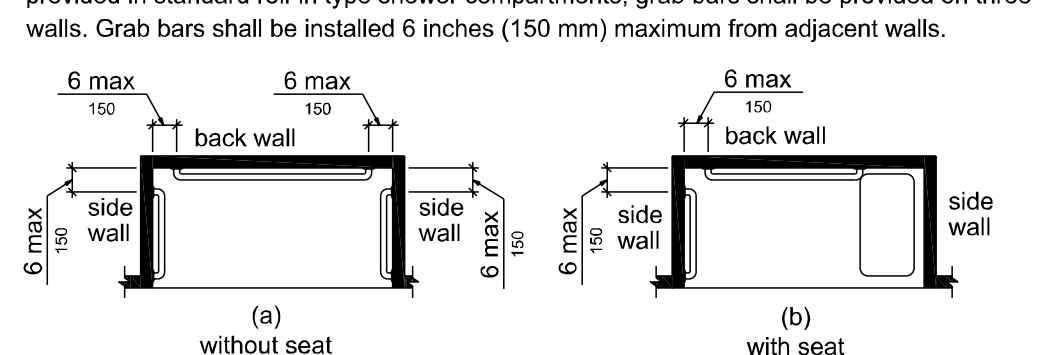


Figure 608.3.2 Grab Bars for Standard Roll-In Type Showers

608.3.3 Alternate Roll-In Type Shower Compartments. In alternate roll-in type shower compartments, grab bars shall be provided on the back wall and the side wall farthest from the compartment entry. Grab bars shall not be provided above the seat. Grab bars shall be installed 6 inches (150 mm) maximum from adjacent walls.

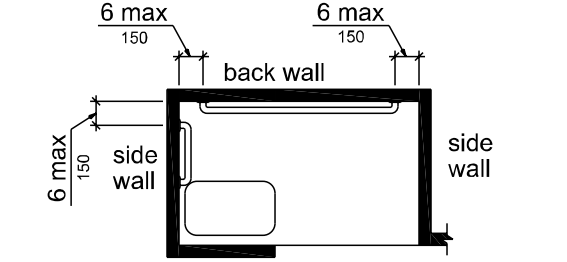


Figure 608.3.3 Grab Bars for Alternate Roll-In Type Showers

608.4 Seats. A folding or non-folding seat shall be provided in transfer type shower compartments. A folding seat shall be provided in roll-in type showers required in transient lodging guest rooms with mobility features complying with 806.2. Seats shall comply with 610.

608.5 Controls. Controls, faucets, and shower spray units shall comply with 309.4.

608.5.1 Transfer Type Shower Compartments. In transfer type shower compartments, the controls, faucets, and shower spray unit shall be installed on the side wall opposite the seat 36 inches (965 mm) minimum and 48 inches (1220 mm) maximum above the shower floor and shall be located on the control wall 15 inches (380 mm) maximum from the centerline of the seat toward the shower opening.

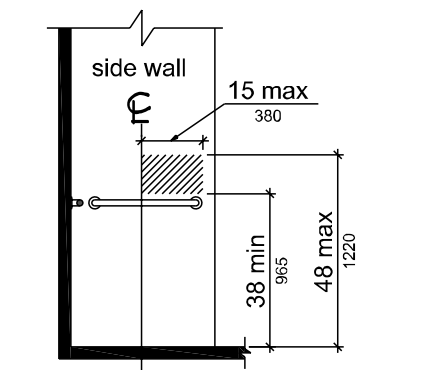


Figure 608.5.1 Transfer Type Shower Compartment Control Location

608.5.2 Standard Roll-In Type Shower Compartments. In standard roll-in type shower compartments, the controls, faucets, and shower spray unit shall be located above the grab bar, but no higher than 48 inches (1220 mm) above the shower floor. Where a seat is provided, the controls, faucets, and shower spray unit shall be installed on the back wall adjacent to the seat wall and shall be located 27 inches (685 mm) maximum from the seat wall.

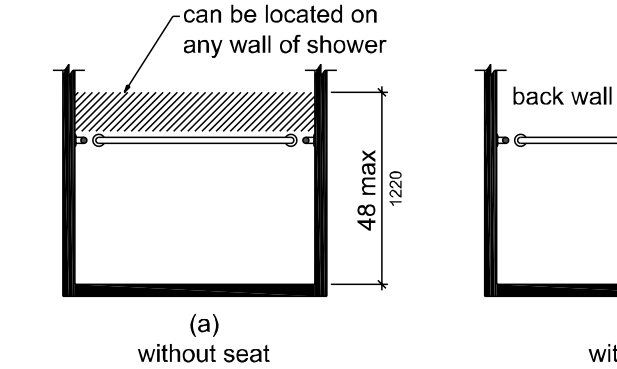


Figure 608.5.2 Standard Roll-In Type Shower Compartment Control Location

608.5.3 Alternate Roll-In Type Shower Compartments. In alternate roll-in type shower compartments, the controls, faucets, and shower spray unit shall be located on the side wall opposite the seat wall and shall be located 27 inches (685 mm) maximum from the seat wall.

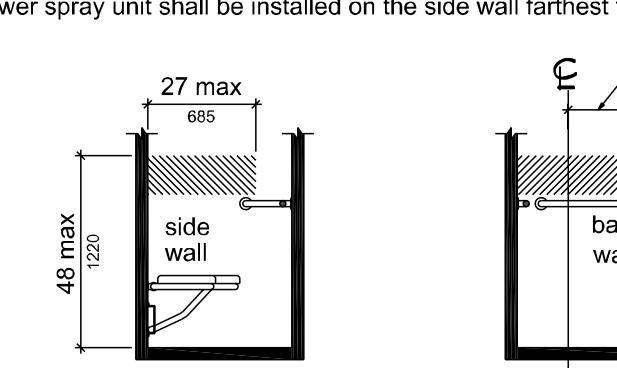


Figure 608.5.3 Alternate Roll-In Type Shower Compartment Control Location

608.6 Shower Spray Unit and Water. A shower spray unit with a hose 59 inches (1500 mm) long minimum that can be used both as a fixed-position shower head and as a hand-held shower shall be provided. The shower spray unit shall have an on/off control with a non-positive shut-off. If an adjustable-height shower head on a vertical bar is used, the bar shall be installed so as not to obstruct the use of grab bars. Shower spray units shall deliver water that is 120°F (49°C) maximum.

608.7 Thresholds. Thresholds in roll-in type shower compartments shall be 1/2 inch (13 mm) high maximum in accordance with 303. In transfer type shower compartments, thresholds 1/2 inch (13 mm) high maximum shall be beveled, rounded, or vertical.

608.8 Shower Enclosures. Enclosures for shower compartments shall not obstruct controls, faucets, and shower spray units or obstruct transfer from wheelchairs onto shower seats.

609 Grab Bars

609.1 General. Grab bars in toilet facilities and bathing facilities shall comply with 609.

609.2 Cross Section. Grab bars shall have a cross section complying with 609.2.1 or 609.2.2.

609.2.1 Circular Cross Section. Grab bars with circular cross sections shall have an outside diameter of 1 1/4 inches (32 mm) minimum and 2 inches (51 mm) maximum.

609.2.2 Non-Circular Cross Section. Grab bars with non-circular cross sections shall have a cross-section dimension of 2 inches (51 mm) maximum and a perimeter dimension of 4 inches (100 mm) minimum and 4.8 inches (120 mm) maximum.

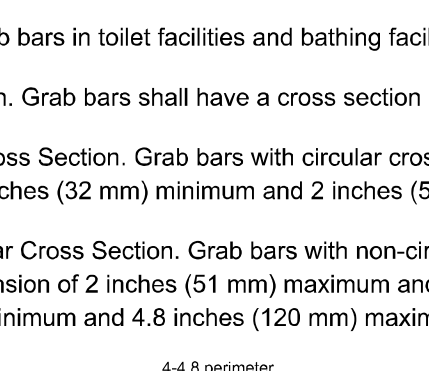


Figure 609.2.2 Grab Bar Non-Circular Cross Section

NOTE: ALTHOUGH EVERY EFFORT HAS BEEN MADE IN THE DRAWING, THE ARCHITECT ASSUMES NO LIABILITY FOR CHECKING THE PLANS FOR CONSTRUCTION ERRORS BEFORE CONSTRUCTION BEGINS.



DARBY CLARKE ARCHITECT AIA NCARB