

GLTV and HGLTV hangers are designed for use with structural composite lumber headers, and may take heavy loads. The top flange nails are sized and specifically located to prevent degradation of the header due to splitting of laminations.

For heavy loads with a face-mount application, see the HGUS series.

MATERIAL: Top flange—3 gauge; Stirrups—7 gauge

FINISH: Simpson gray paint

ALLOWABLE LOADS: • For hanger heights exceeding the joist height, the allowable load is 0.50 of the table load.

INSTALLATION: • Use all specified fasteners. Verify that the header can take the required fasteners specified in the table.

- This series may be used for weld-on applications. Minimum required weld is a 3/16" x 2 1/2" fillet weld at each end of the top flange for GLTV, and a 1/4" x 2 1/2" fillet weld at each end of the top flange for HGLTV, see page 11 for weld information. Weld-on applications produce maximum loads listed. Uplift loads do not apply to this application.
- Web stiffeners are required with I-joists using this hanger style.
- GLTV may be installed on a nailer and ledger; HGLTV may be installed on a ledger only. Nailers and ledgers must be a minimum of 4x lumber to guarantee the load values given in the tables. Thinner lumber or laminated veneer lumber used as a nailer must be evaluated by the building designer.

OPTIONS: • Hot-dipped galvanized: specify HDG.

- See Hanger Options, page 164.

CODES: See page 10 for Code Listing Key Chart.

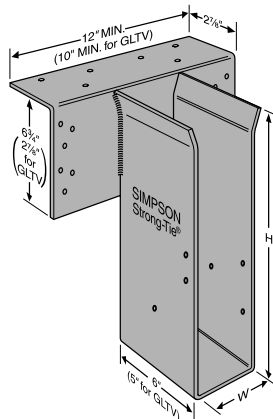

HGLTV
(GLTV similar)

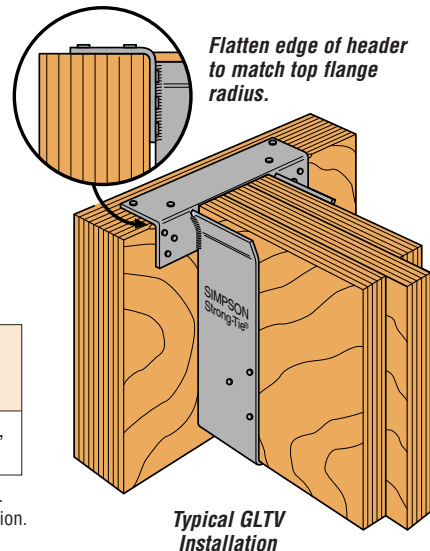

Typical GLTV Installation

Model No.	Fasteners			Down Avg Ult DF/SP	Allowable Loads							Code Ref.
	Top	Face	Joist		Uplift (133)	Uplift (160)	DF/SP LVL ⁵	PSL ³	LSL ⁴	DF/SP	SPF	
GLTV series	4-16d	6-16d	6-16d	24450	1370	1640	7500	7400	5750	7000	4260	7, 90, 121
HGLTV series	6-16d	12-16d	6-16d	26167	1370	1640	10500	7800	9000	8665	6690	

1. Uplift loads have been increased 33% and 60% for wind or earthquake loading with no further increase allowed. Divide by 1.33 and 1.60 for normal loading such as in cantilever construction.
2. Uplift loads only apply when "H" is 28" or less.

3. If header is multiple plies of 1 3/4", the PSL allowable load is 6000 lbs.
4. HGLTV at maximum allowable load may have greater than 1/8" deflection.
5. Applies to LVL headers made primarily from Douglas Fir or Southern Pine. For LVL made primarily from Spruce Pine Fir or similar less dense veneers, use the values found in the SPF column.