

Builder must check correctness of this drawing PRIOR to erection of this system. This drawing is conceptual and should be used with the Architectural plans to insure proper joist and beam placement. Stairways may be drawn small to allow for adjustments in the field.

BEARING WALLS AND POINT LOADS FROM FLOORS ABOVE DIRECTLY EFFECT SLAB OR FLOORS BELOW AND SHOULD BE ADDRESSED PRIOR TO INSTALLATION OF SLAB OR FLOORS BELOW IF NOT DIRECTLY ADDRESSED IN THESE LAYOUTS

Symbols for reference only. Framers to verify fixture locations for proper joist adjustments.



DN01 DO NOT cut, notch or drill flanges

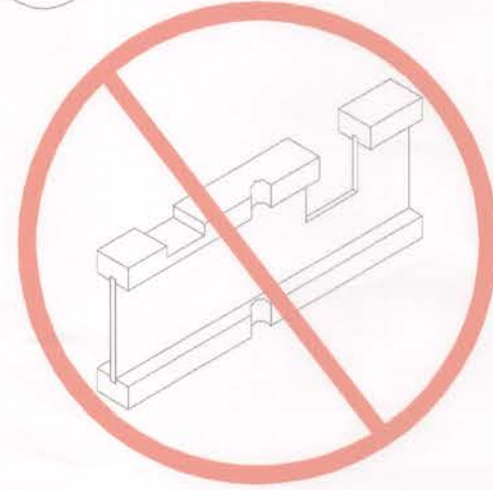

DN03 DO NOT support joist by top flange and/or web.

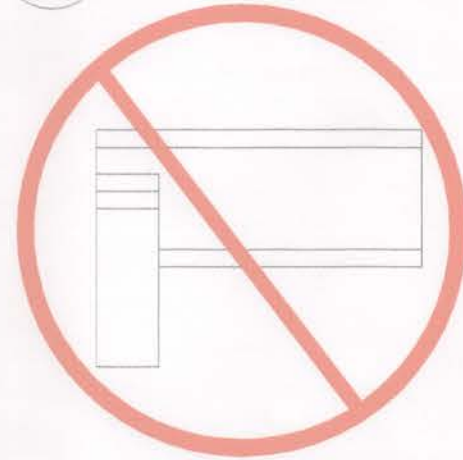

DN04 DO NOT cut holes near bearing support

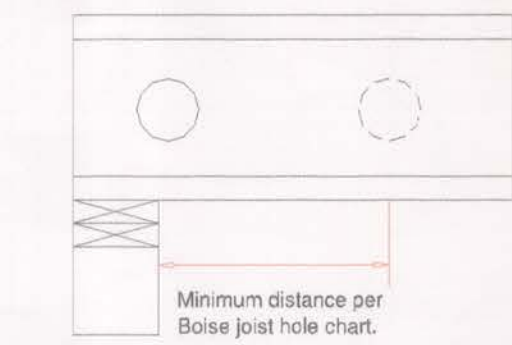

PlotID	Qty	Manuf	Product
Hu1	7	Simpson	ITS2.37/16
Hu2	232	Simpson	ITS2.37/16

PlotID	Net Qty	Product	Length	Piles
1	29	16" BC#8 6000s-1.8	24' 0"	1
2	205	16" BC#8 6000s-1.8	22' 0"	1
3	126	16" BC#8 6000s-1.8	20' 0"	1
4	138	16" BC#8 6000s-1.8	18' 0"	1
5	17	16" BC#8 90s-2.0	22' 0"	1
6-4	32	1-3/4" x 16" VERSA-LAM# 2.0 3100 SP	18' 0"	4
7-4	8	1-3/4" x 16" VERSA-LAM# 2.0 3100 SP	16' 0"	4
8-3	3	1-3/4" x 16" VERSA-LAM# 2.0 3100 SP	14' 0"	3
9-3	3	1-3/4" x 16" VERSA-LAM# 2.0 3100 SP	12' 0"	3
Ca1	3	1-1/8" x 16" BC RIM BOARD OSB	22' 0"	1
Ca2	2	1-1/8" x 16" BC RIM BOARD OSB	12' 0"	1
Ca3	7	1-1/8" x 16" BC RIM BOARD OSB	10' 0"	1
Ca4	2	1-1/8" x 16" BC RIM BOARD OSB	4' 0"	1
Ca5	2	1-1/8" x 16" BC RIM BOARD OSB	2' 0"	1
Ca2	83	1-1/8" x 16" BC RIM BOARD OSB	12' 0"	1
Bk1	4	16" BC#8 6000s-1.8	2' 0"	1

NOTE: ALL MEASUREMENTS TO BE VERIFIED IN THE FIELD.

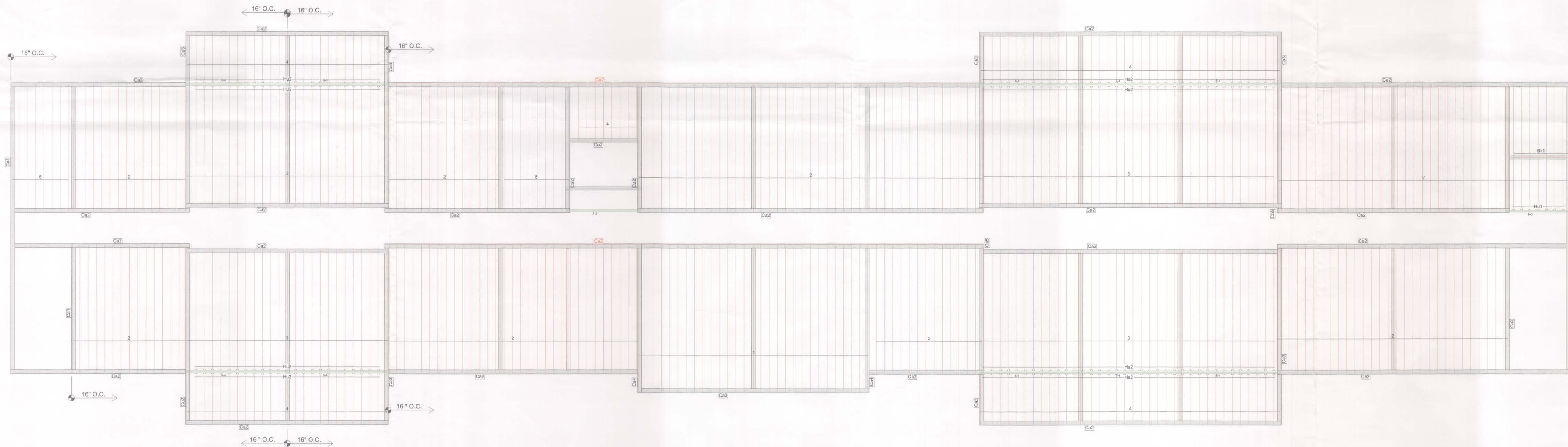

Floor 2

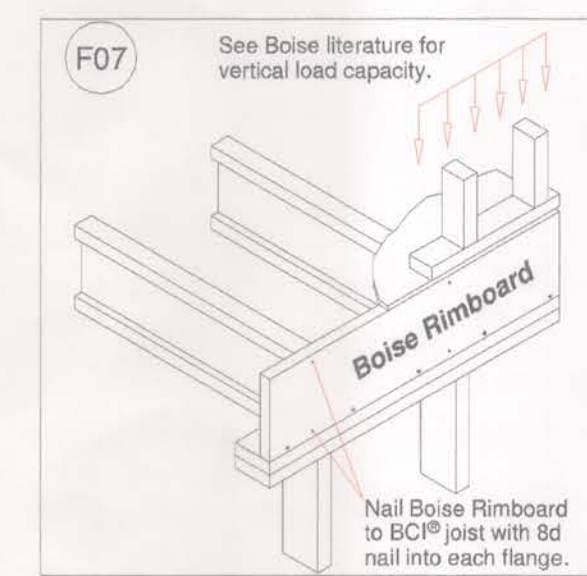
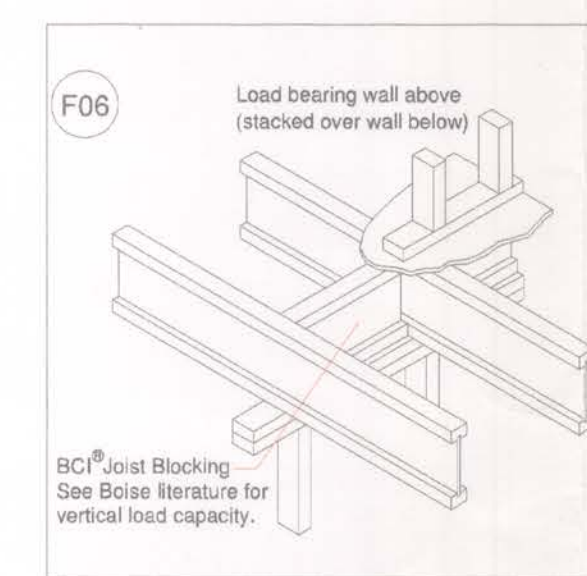
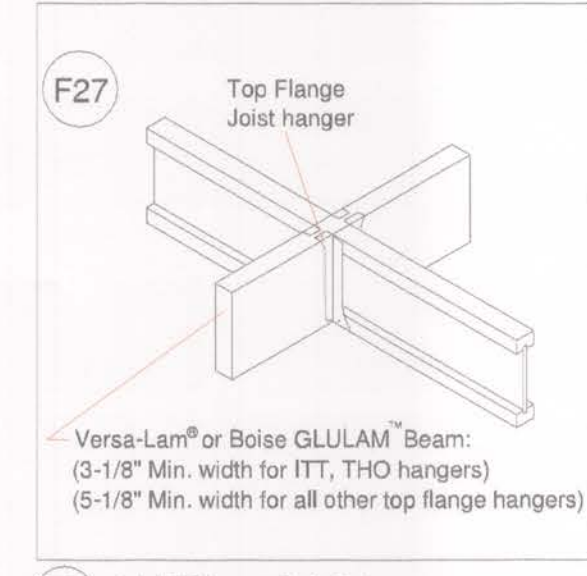
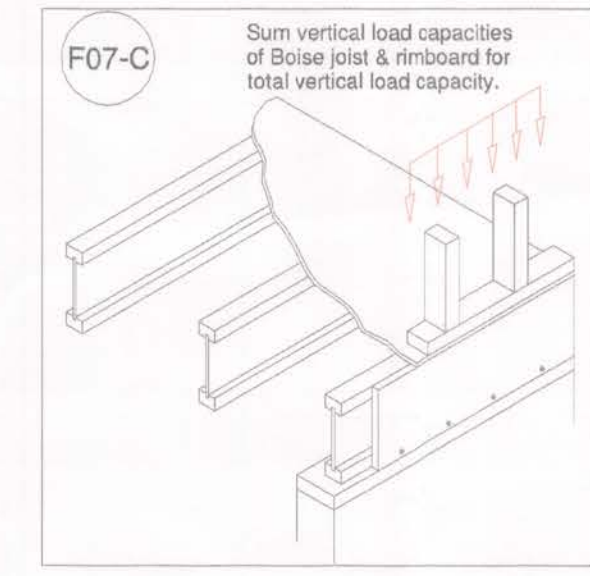
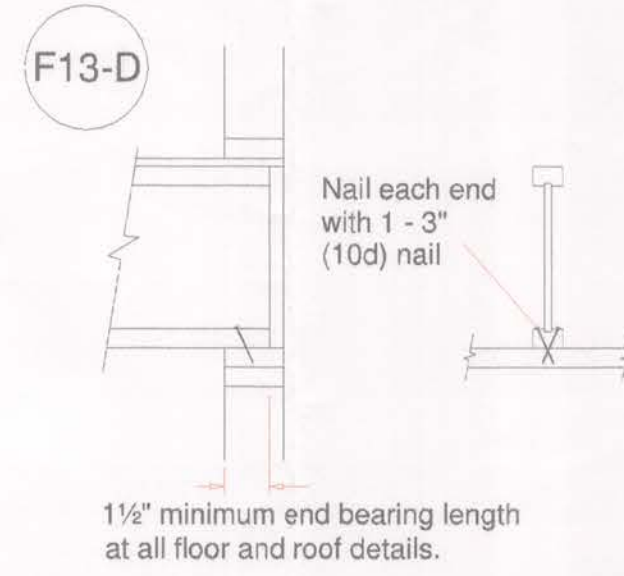
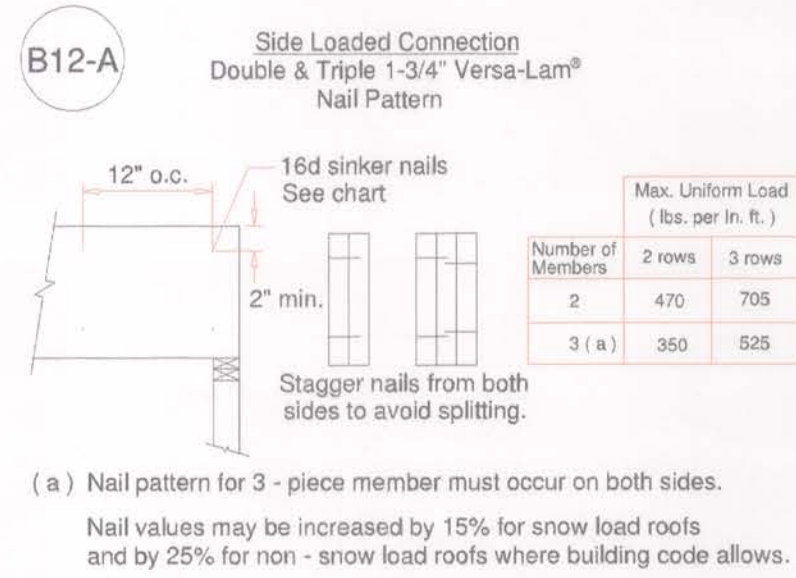

16" O.C.

Abita Lumber -
Mainstay Suites - 700 Main St.
Hackberry

BC FRAMER
Scale: N.T.S.
Date: 6-10-16
By: Ronnie Talley
File: 21271
DWG:
Sheet: 1/1

