

NOTES

- 1) This is a ground-supported, stiffened, mat foundation designed in accordance with PFI DC10.5-1.2.
- 2) Differential settlement cannot be entirely avoided. This design is intended to mitigate the negative effects of differential settlement.
- 3) Self-weight Dead Load = as calculated
- 4) Partition Dead Load = 15 psf
- 5) Floor Live Load = 40 psf
- 6) Roof Live Load = 20 psf
- 7) Attic Live Load = 10 psf
- 8) No field supervision provided under this seal.
- 9) Contractor shall perform work in accordance with governing codes.
- 10) Contractor shall coordinate post-tension (PT) installation drawings with architectural, electrical, and mechanical drawings for all openings, inserts, and other related items.
- 11) Loading of slab and/or framing prior to tendon stressing is not permitted without the approval of the Engineer of Record (E.O.R.).
- 12) DO NOT form from this plan.
- 13) This plan is to be used for beam layout and tendon placement only.
- 14) Contractor shall verify all foundation dimensions, formwork, drops, offsets, brick ledges, and block-outs per architectural drawings prior to construction.
- 15) Contractor shall complete all formwork including: brick ledges, drop forms, block-outs, depression forms, etc. prior to PT installation. Any change after PT installation requires the written approval of Coast Concrete Services (CCS), Inc. prior to concrete placement.
- 16) Contractor shall remove forms within 24 hours to accommodate partial prestress when required. Contractor should remove forms no later than 3 days after concrete placement if no partial stress is required.
- 17) Disregard all code tolerances, 4" slab thickness is minimum allowed.
- 18) Grade beam dimensions shown are minimum required and shall not be reduced.
- 19) Locate pipes/conduits (p/c) beneath slab depth. Locate p/c outside of girth/footings (exception: those intersecting grade beams shall do so within the middle third of footing depth.)
- 20) Plumbing hangers shall be securely fixed in place prior to concrete placement.
- 21) A minimum 6 mil polyethylene vapor retarder shall be placed under the entire slab area and shall be pinned to the vertical face and/or bottom of grade beams in order to prevent entanglement during concrete placement. Vapor retarder shall not be continuous through grade beams.
- 22) Repairs and joints shall conform to manufacturer's standards.
- 23) All mild steel reinforcement shall conform to ASTM A615 (Grade 60).
- 24) All welded wire fabric (WWF) shall conform to ASTM A185 (Flat sheets). #3 @ 12" o.c. can be used in lieu of WWF.
- 25) Rebar in grade beams shall have 3" minimum clear cover on all sides. Rebar and WWF in slab shall have 1-1/2" bottom and 3/4" top minimum clear cover.
- 26) For full masonry fireplaces, an optional 24" deep footing may be used under footprints w/#5 @ 12" each way, bottom.
- 27) All prestressed steel shall consist of 7/8" seven wire, stress relieved, low-relaxation strand conforming to ASTM A416. Minimum ultimate tensile strength shall be 270 ksi.
- 28) Tendons shall be stressed to 33.0 kips within 6-10 days after concrete placement.
- 29) Strands shall be coated with a permanent rust preventative lubricant and continuous 40 mil nominal plastic sheathing.
- 30) PT system shall be furnished, placed, and stressed by CCS, Inc. CCS, Inc. supervisor and a minimum of 50% of personnel are certified under the PFI Slab-on-Ground Stressor Installer Program.
- 31) Installation by others will void CCS, Inc. of responsibility.
- 32) Tendon anchors shall be located at a minimum of 4" below top of concrete.
- 33) Fixed and stress-ends may be reversed at convenience of the PT installer.
- 34) Tendon location may be field adjusted horizontally up to 1/2". Movement further than 1/2" requires approval of E.O.R.
- 35) All tendons greater than 110'-0" in length shall be stressed to 33 kips from both ends.
- 36) Tendon elongations shall conform to a ± 1.0% tolerance unless approved by E.O.R.
- 37) Installation sequence of conventional reinforcement and tendons shall be coordinated by general contractor and PT installer.
- 38) PT tendon placement takes precedence over rebar.
- 39) Tendon supports shall be spaced at 4'-0" o.c. max.
- 40) Sheathing shall be removed 10' - 12" from a fixed-end anchor & shall be removed 1" maximum from a stressing-end anchor.
- 41) When partial prestress is required, tendons shall be stressed to 30% of full jacking force within 48 hours after concrete placement.
- 42) Tendon tails shall be cut within 1 day after elongation approval.
- 43) Tendon tails shall be covered with plastic caps after cutting. Plastic caps shall cover 1" of the tendon tail and shall be filled with PT coating.
- 44) Stressing pockets shall be filled with non-shrink grout within 7 days after E.O.R. approves tendon elongations.
- 45) Concrete shall be 3000 psi minimum compressive strength at 28 days.
- 46) Concrete shall be 2000 psi minimum compressive strength at time of full stressing.
- 47) Concrete temperature shall not exceed 90° Fahrenheit prior to placement.
- 48) Concrete slump shall be 4" ± 1" unless permitted to increase with the use of water reducing admixture.
- 49) Concrete shall not exceed 90 minutes from batch time to time of placement.
- 50) The use of calcium chloride is prohibited.
- 51) Contractor shall cure concrete in accordance with ACI 308-Guide to Curing Concrete.
- 52) Concrete shall be placed monolithically (u.o.n.) without cold joints.
- 53) Concrete shall be thoroughly consolidated especially at tendon anchorages.
- 54) Contractor shall use a bond breaker membrane between foundation and brittle flooring materials (brick, tile, stone, etc.) due to possible flexure of slab.
- 55) Contractor shall inspect floor areas for shrinkage cracks prior to installation of brittle flooring materials.
- 56) Flooring contractor shall treat cracks in accordance with dry set mortar manufacturer's recommendation prior to installation of brittle flooring materials.
- 57) Floor area utilizing concrete as an architectural feature should be brought to the design engineer's attention prior to concrete placement for additional reinforcement and jointing details.
- 58) Fill shall be an inert granular material compacted in 6" lifts to 90%. Standard Proctor (or greater as required by local code.) Compaction shall be in accordance with ASTM D698. Foundation is designed for minimum allowable bearing capacity of 1,000 PSF (SF of 3) and PI < 20. Each lot which requires total fill materials in excess of 12' over undisturbed soil will warrant further geotechnical testing. The contractor/homeowner shall maintain positive drainage away from the foundation at all times.
- 59) Piles size and tip embedment shall be as indicated on plan unless driven to refusal (refusal shall be as specified in geotechnical report/building code). Piles are not to be vibrated. Timber piles shall be per ASTM D225 and shall meet ANPA standards CS-92 for preservative retention. The owner/contractor shall verify the size of each pile used and keep a log of the driving record of each pile. Only license pile driving contractors shall be used for pile installation. Failure to adhere to any of these specifications will void the engineer's design and hold engineer harmless if differential settlement occurs.

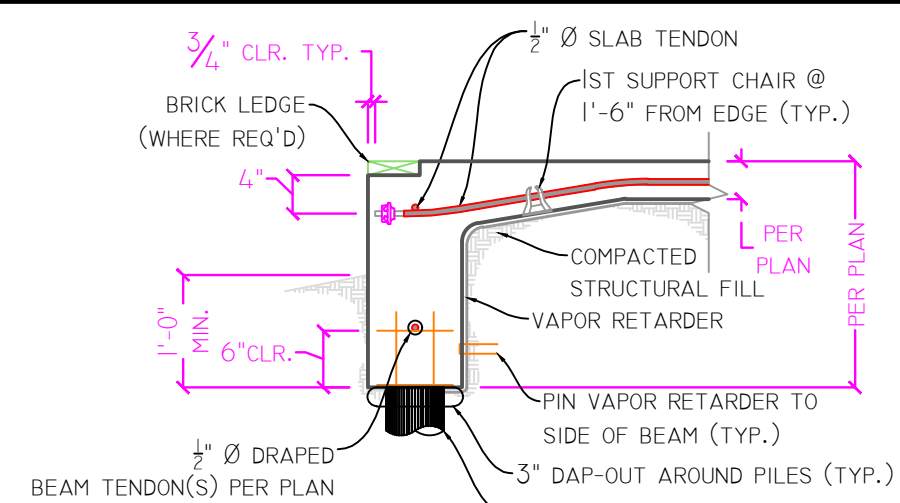

21 EXTERIOR BEAM SECTION w/PILES
Scale: 3/4" = 1'-0"

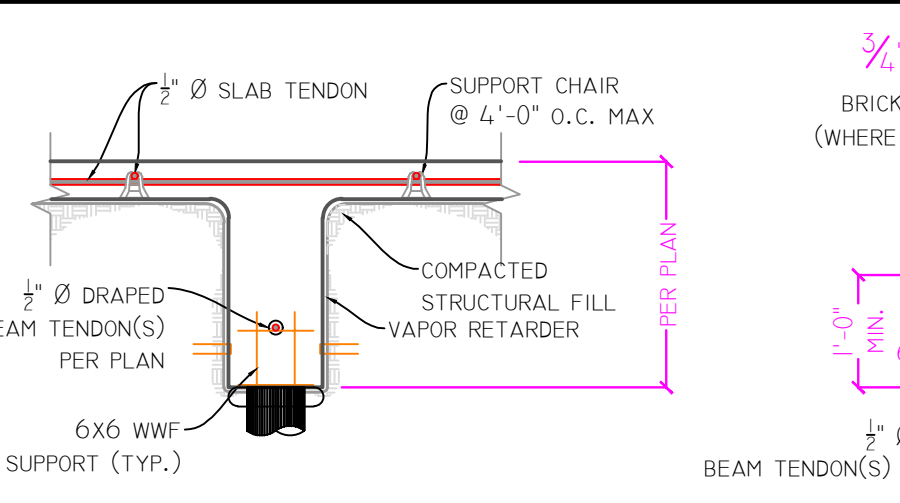

22 INTERIOR BEAM SECTION w/PILES
Scale: 3/4" = 1'-0"

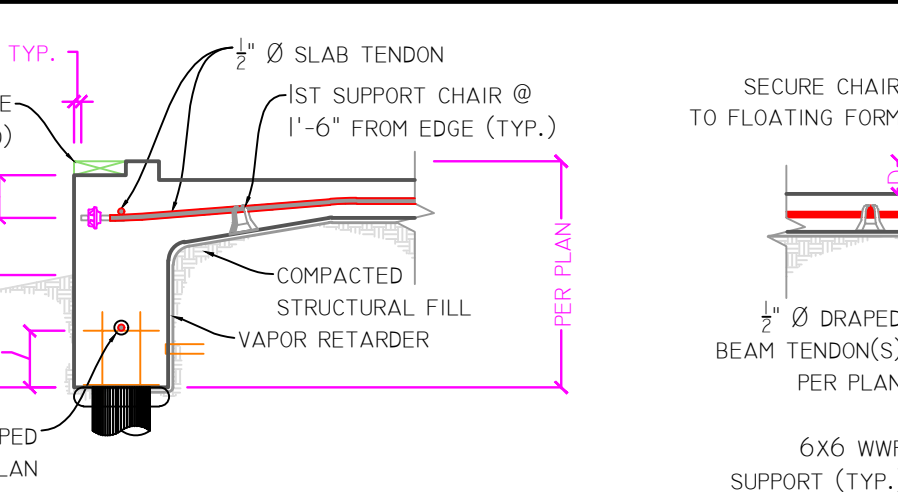

23 EXTERIOR BEAM SECTION AT GARAGE w/PILES
Scale: 3/4" = 1'-0"

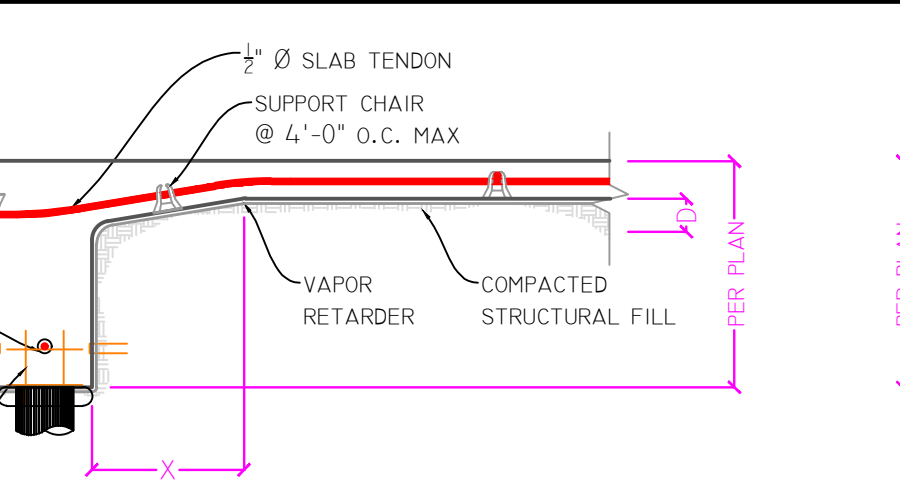

24 INTERIOR BEAM TENDON TRANSITION w/PILES
Scale: 3/4" = 1'-0"

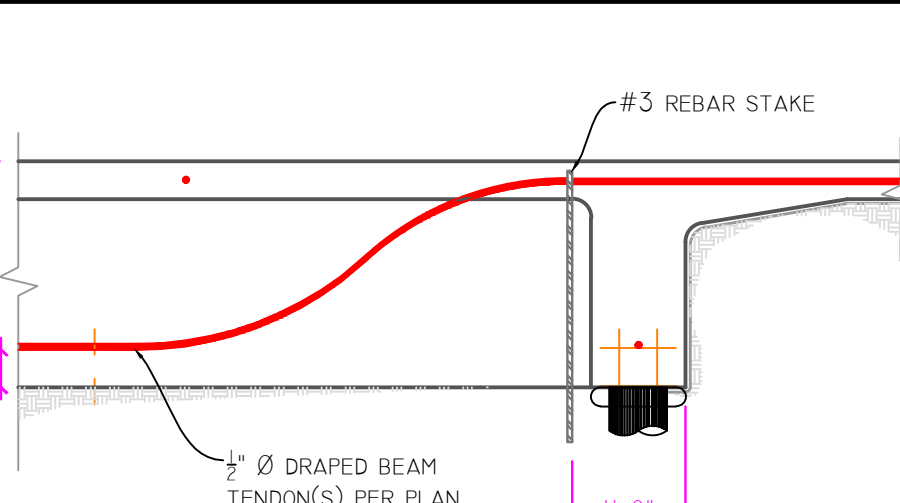

25 INTERIOR BEAM TENDON TRANSITION w/PILES
Scale: 3/4" = 1'-0"

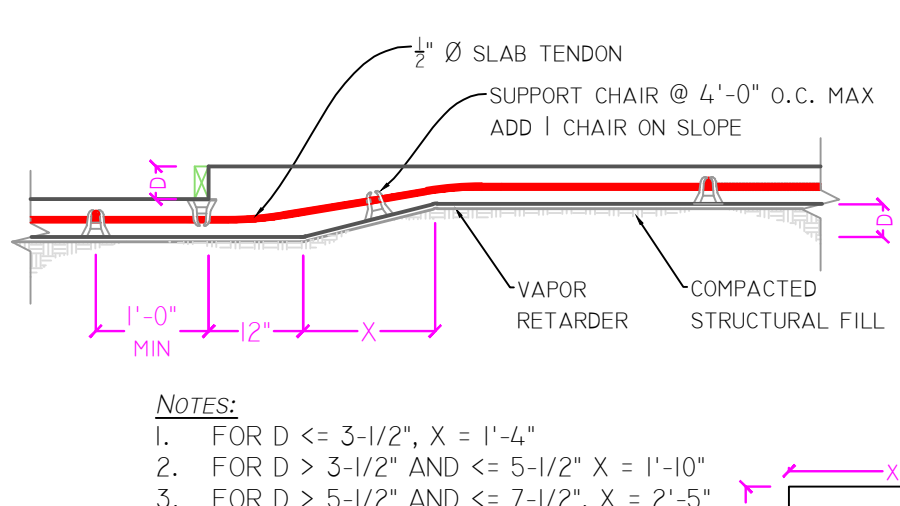

26 THICKENED SLAB TENDON TRANSITION w/PILES
Scale: 3/4" = 1'-0"

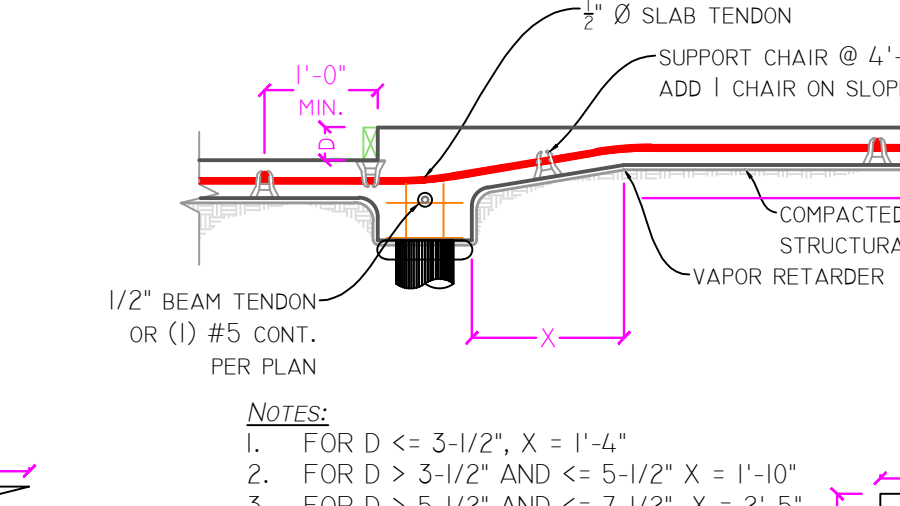

27 THICKENED SLAB TENDON TRANSITION w/PILES
Scale: 3/4" = 1'-0"

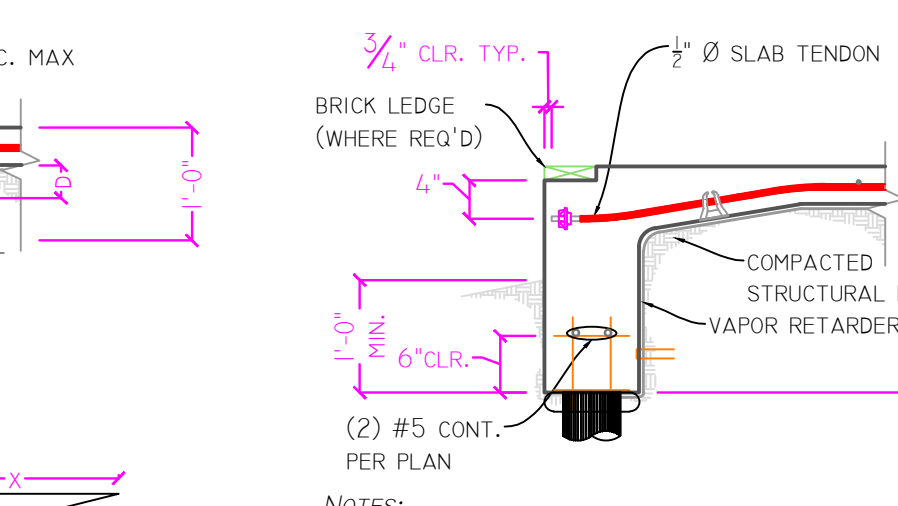

28 EXTERIOR BEAM SECTION w/ REBAR & PILES
Scale: 3/4" = 1'-0"

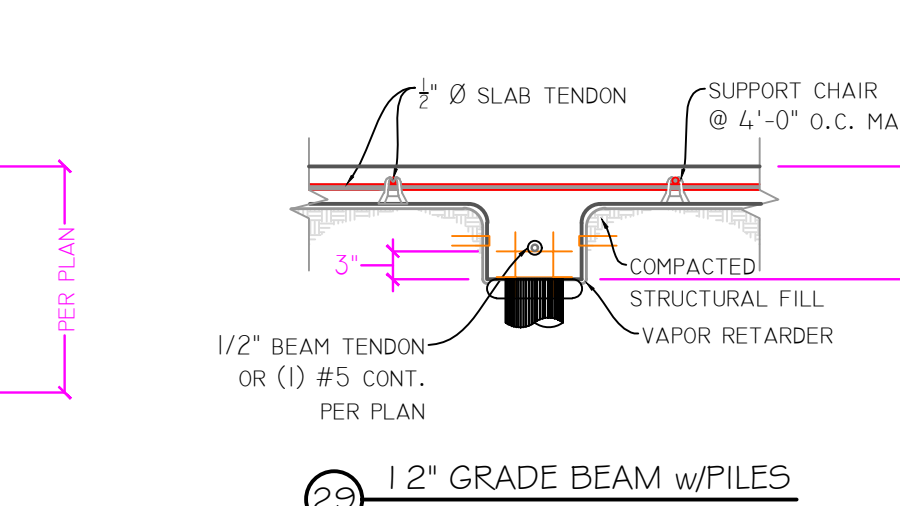

29 12" GRADE BEAM w/PILES
Scale: 3/4" = 1'-0"

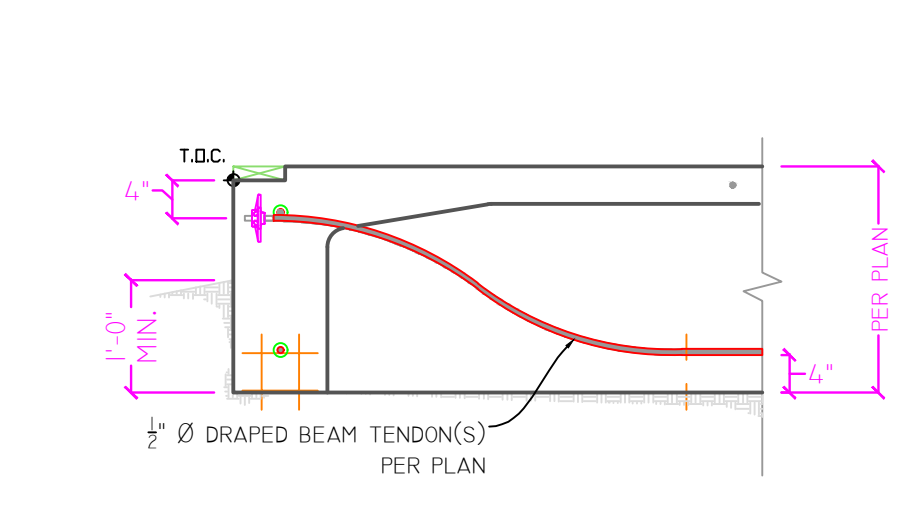

30 TYPICAL TENDON DRAPE AT EXT. BEAM INTERSECTION w/PILES
Scale: 3/4" = 1'-0"

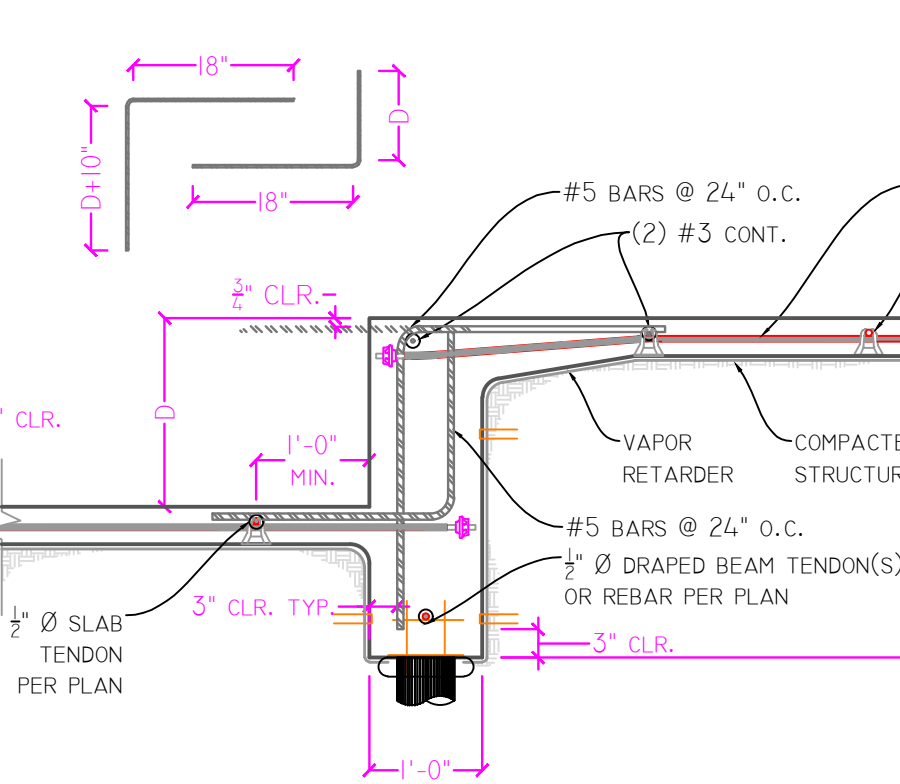

31 STOP-START FOR D <= 36" w/PILES
Scale: 3/4" = 1'-0"

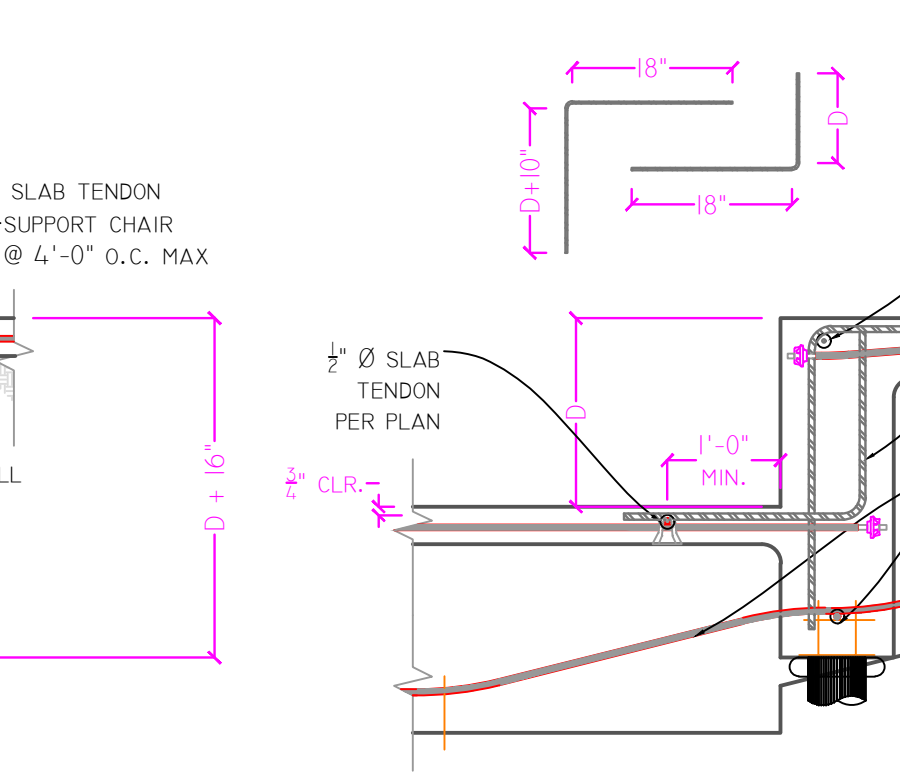

32 STOP-START AT BEAM TRANSITION FOR D <= 36" w/PILES
Scale: 3/4" = 1'-0"

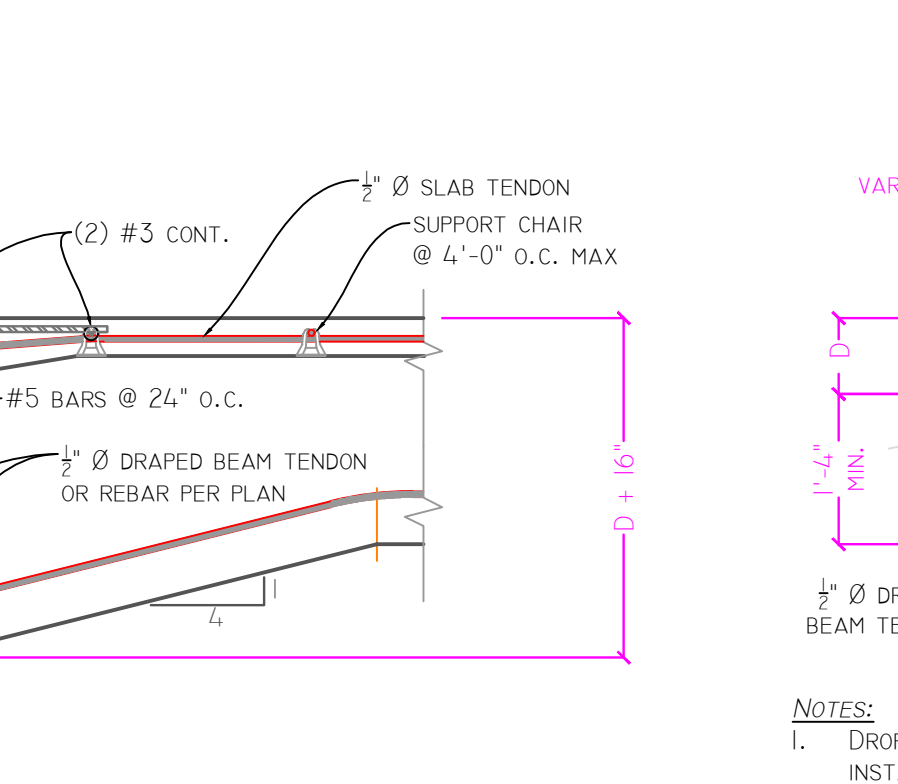

33 EXTERIOR BEAM AT DROP BRICK LEDGE <= 8" w/PILES
Scale: 3/4" = 1'-0"

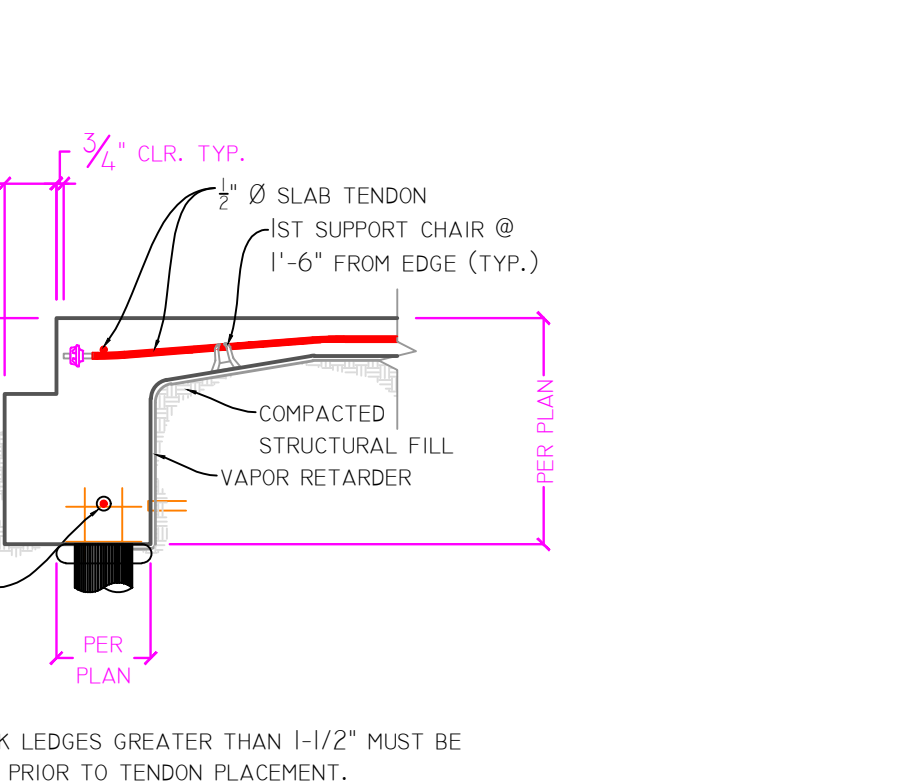

34 EXTERIOR BEAM AT DROP BRICK LEDGE <= 36" w/PILES
Scale: 3/4" = 1'-0"

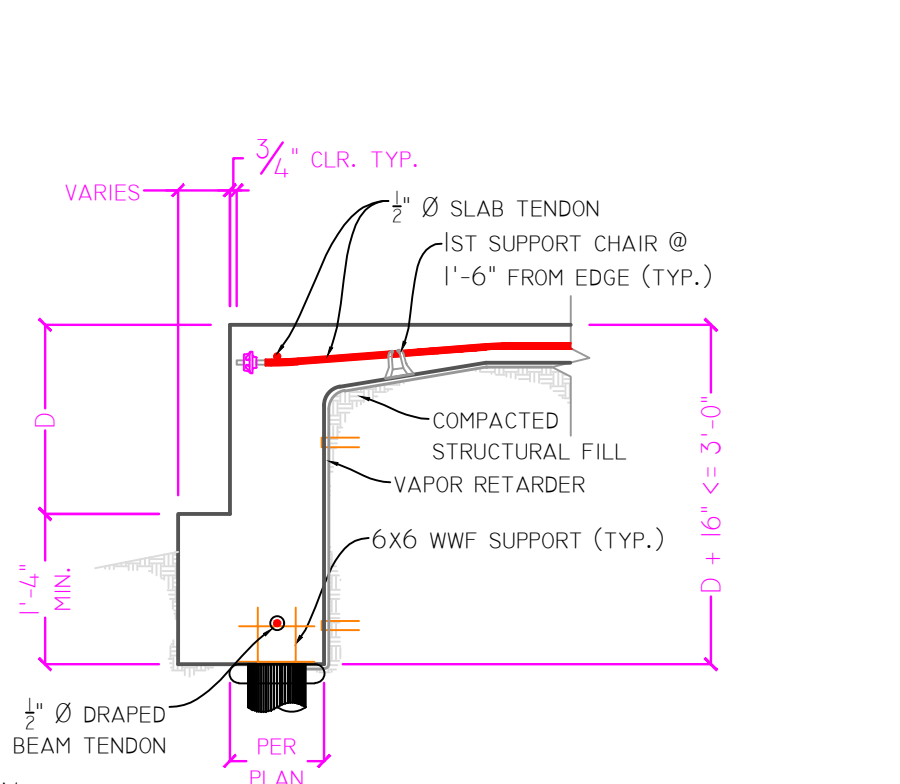

35 BEAM AT EXISTING FOUNDATION w/PILES
Scale: 3/4" = 1'-0"

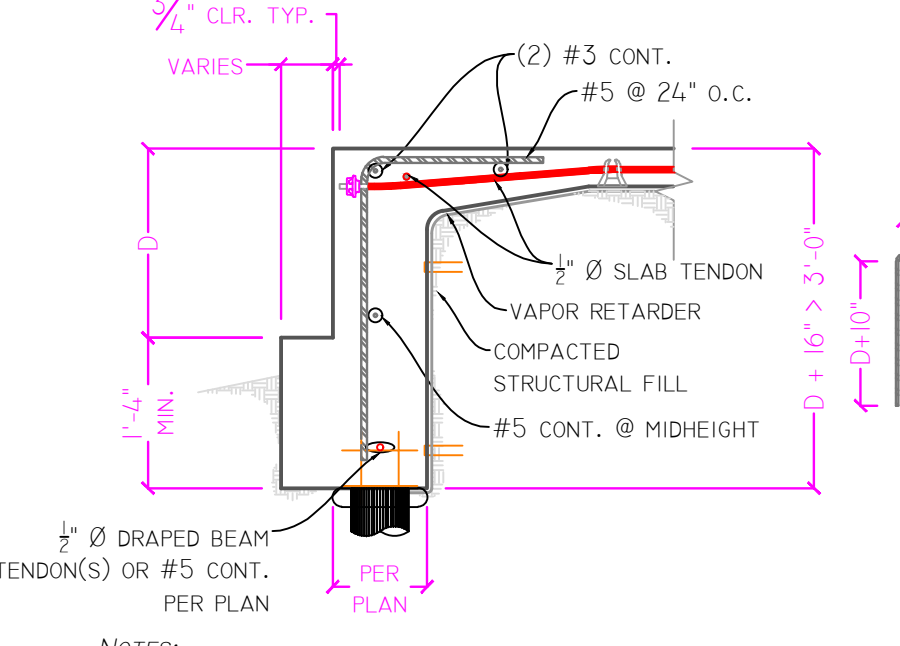

36 EXTERIOR COLUMN FOOTING w/PILES
Scale: 3/4" = 1'-0"

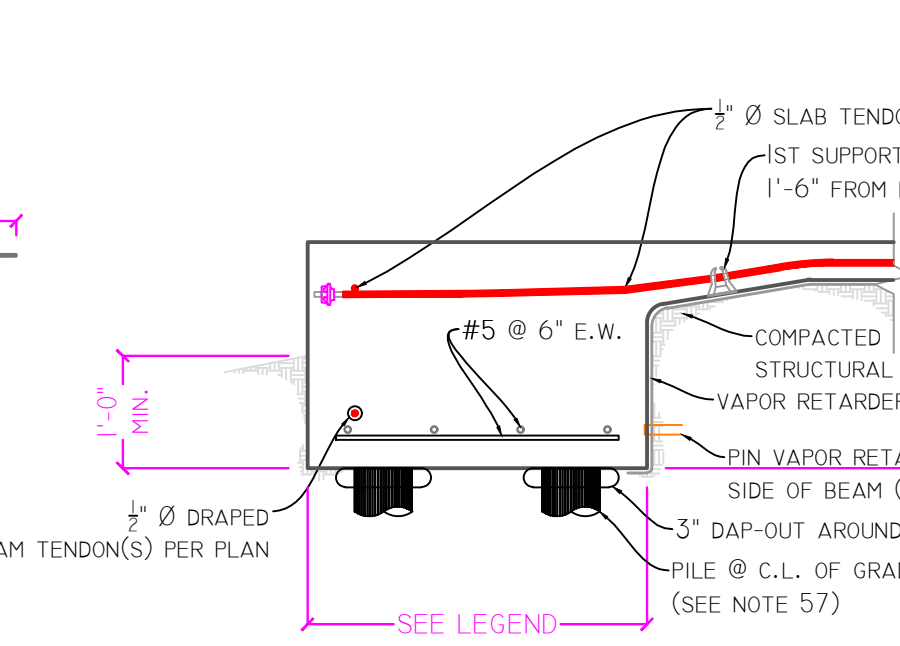

37 INTERIOR COLUMN FOOTING w/PILES
Scale: 3/4" = 1'-0"

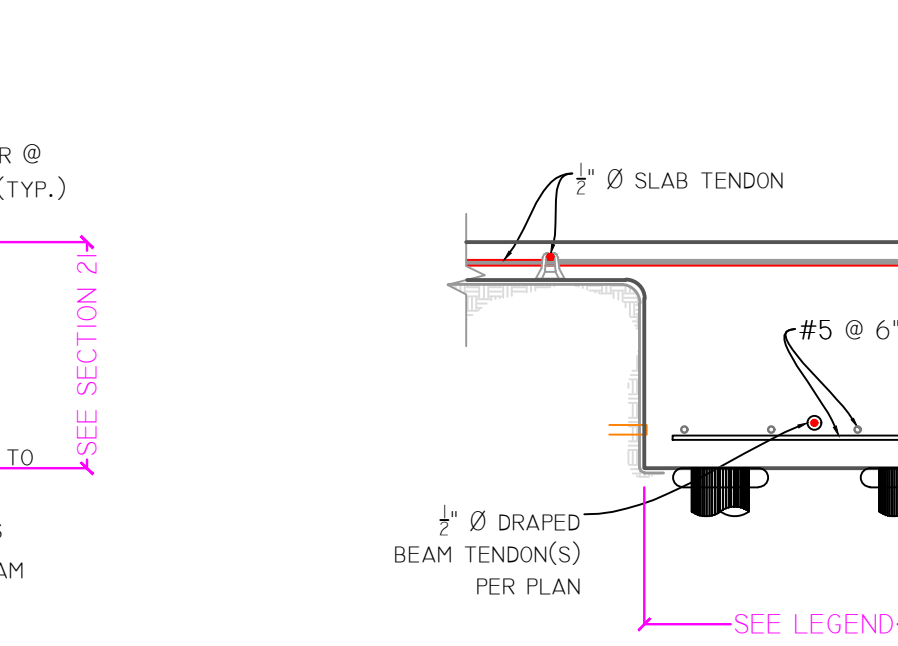

38 BEAM AT EXISTING FOUNDATION w/PILES
Scale: 3/4" = 1'-0"

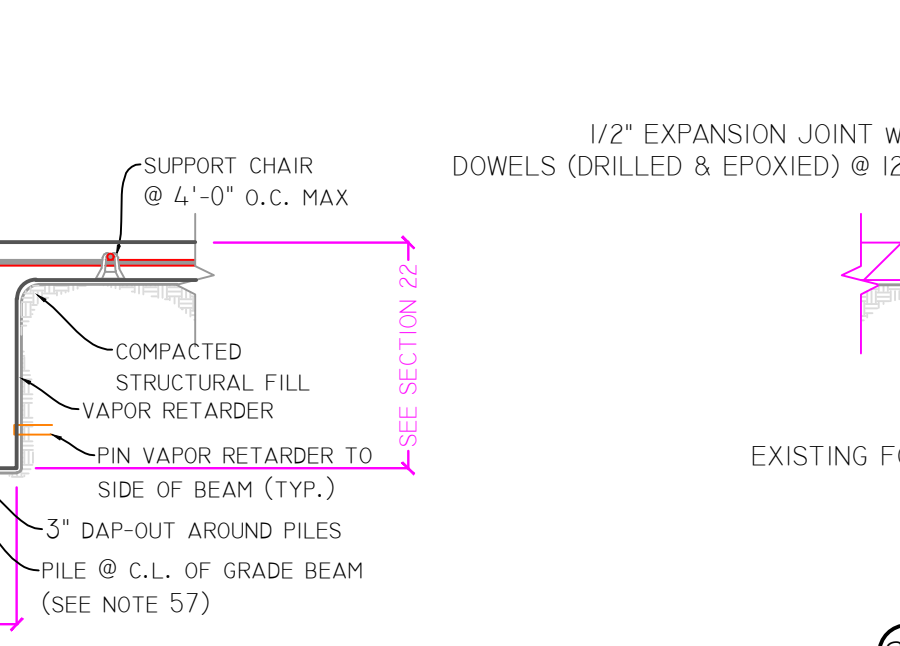

39 SINGLE PILE CAP
Scale: 3/4" = 1'-0"

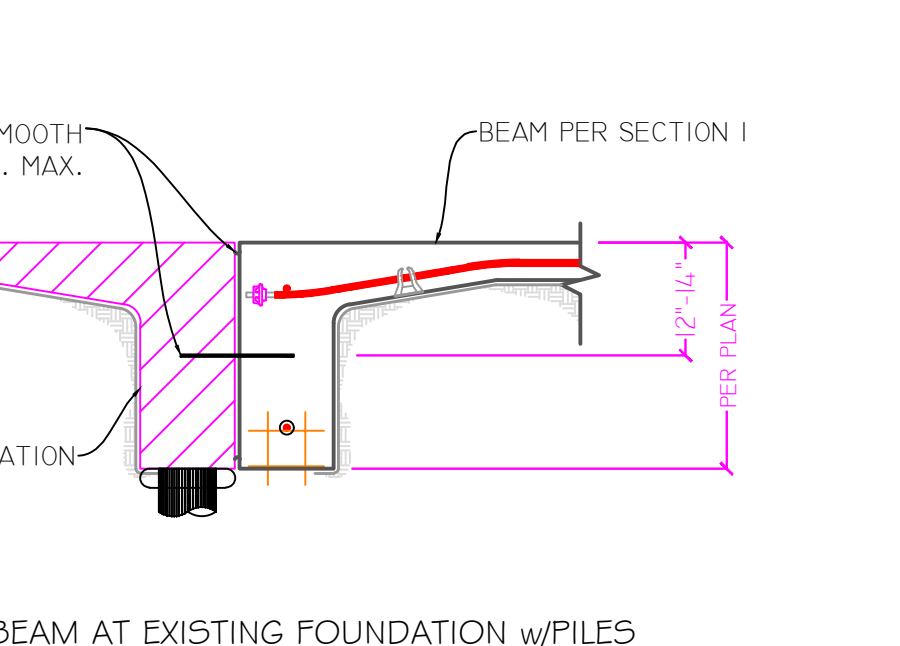

40 TYPICAL OPENING > 2'-0" DETAILS
Scale: 3/4" = 1'-0"

REVISIONS		
REV	DATE	CAD

DESCRIPTION	

NOTES & SECTIONS

CUSTOMER NAME:	McMATH CONSTRUCTION
MODEL:	FOUNTAINS DOCTOR'S OFFICE
PROJECT:	OAK HARBOR BLVD.
SUBDIVISION/LOT #:	SIDELL, LOUISIANA
ADDRESS:	ST. TAMMANY
CITY/STATE:	
PARISH/COUNTY:	

DATE	DET	REP	SF
5/14/25	MD	TW	9403

PROJECT NO.
25-0729

SHEET NO.
PT-2

REVISIONS		
REV	DATE	CAD
△	-	-
△	-	-
△	-	-

DESCRIPTION
 POST-TENSION PLAN

CUSTOMER NAME: McMATH CONSTRUCTION
 MODEL: FOUNTAINS DOCTOR'S OFFICE
 PROJECT: OAK HARBOR BLVD.
 ADDRESS: SLIDELL, LOUISIANA
 CITY/STATE: ST. TAMMANY
 PARISH/COUNTY:

DATE	DET	REP	SF
5/14/25	MD	TW	9403

PROJECT NO.

25-0729
 SHEET NO.
PT-IB

REBAR		
LENGTH	PLACEMENT	QUANTITY
18'-0"	BEAM	1
5'-0"	BEAM	4
7'-0"	BEAM	2

NOTE: REBAR FOR START/STOP AND/OR DROP BRICK LEDGE TO BE DETERMINED AT JOB SITE.

NOTE: CONTRACTOR TO VERIFY ALL DIMENSIONS PRIOR TO CONSTRUCTION.

LEGEND

(##) SEQUENCE NUMBER
 S-XX SLAB TENDON
 TENDON TYPE-LENGTH

(##) SEQUENCE NUMBER
 B-XX DRAPED BEAM TENDON
 TENDON TYPE-LENGTH

FIXED END

REBAR

(2) #5 CORNER BARS (OPTIONAL)

● PILE: SEE PLAN

SOIL

MAX FILL HEIGHT (24")

SOIL REPORT BY: N/A

VAPOR RETARDER

LAYER(S)	THICKNESS (MIL)
1	6

TENDONS

COUNT	LENGTH
12	S-113
12	S-75
11	S-94
8	S-125
7	S-70
6	S-39
6	B-75
5	B-94
4	B-23
4	S-23
2	S-117
2	S-26
2	B-70
2	B-113
1	B-125
1	S-29
1	B-26
1	B-29
1	B-126
1	B-39

FOUNDATION GEOMETRY

	WIDTH (IN)	DEPTH (IN)
EXTERIOR BEAM	12	24
INTERIOR BEAM	12	24
SLAB	N/A	4

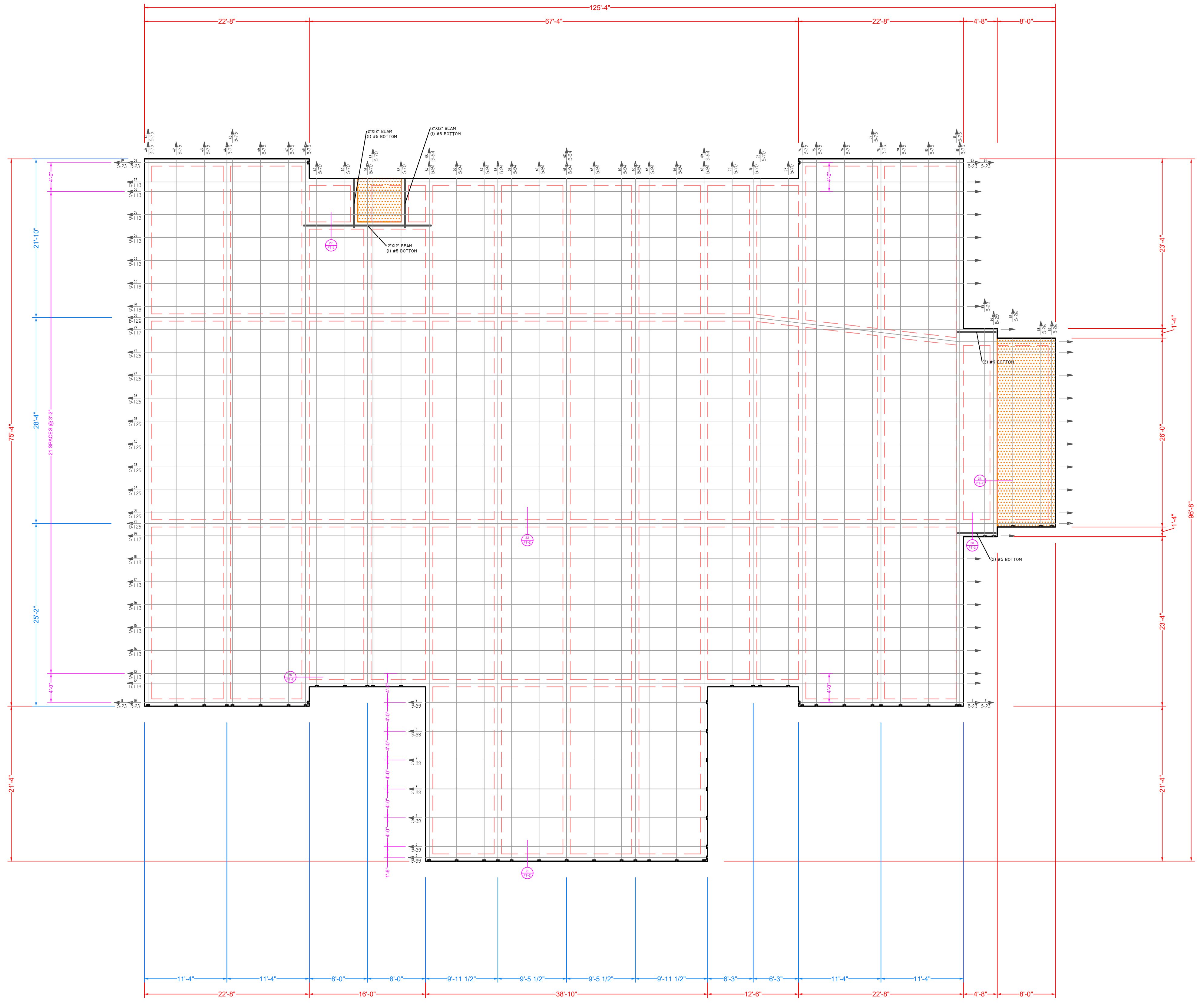

CUT LIST

CUTS	TOTAL LENGTH
89	7317'-0"

SCALE

1/8" = 1'-0"

INSTALLER NOTES

VISQUEEN PILES

REVISIONS		
REV	DATE	CAD
△	-	-
△	-	-
△	-	-

DESCRIPTION
PILE PLAN

CUSTOMER NAME: McMath Construction
 MODEL: FOUNTAINS DOCTOR'S OFFICE
 PROJECT: OAK HARBOR BLVD.
 ADDRESS: SLIDELL, LOUISIANA
 CITY/STATE: ST. TAMMANY
 PARISH/COUNTY:

DATE	DET	REP	SF
5/14/25	MD	TW	9403

PROJECT NO.

25-0729

SHEET NO.

PT-IA

LEGEND

(##) → SEQUENCE NUMBER
 → SLAB TENDON
 S-XX → TENDON TYPE-LENGTH

(##) → SEQUENCE NUMBER
 → DRAPED BEAM TENDON
 B-XX → TENDON TYPE-LENGTH

→ FIXED END

→ REBAR

→ (2) #5 CORNER BARS (OPTIONAL)

● PILE: SEE PLAN

SOIL

MAX FILL HEIGHT (24")

SOIL REPORT BY: N/A

VAPOR RETARDER

LAYER(S)	THICKNESS (MIL)
1	6

FOUNDATION GEOMETRY

	WIDTH (IN)	DEPTH (IN)
EXTERIOR BEAM	12	24
INTERIOR BEAM	12	24
SLAB	N/A	4

NOTE: CONTRACTOR TO VERIFY ALL DIMENSIONS PRIOR TO CONSTRUCTION.

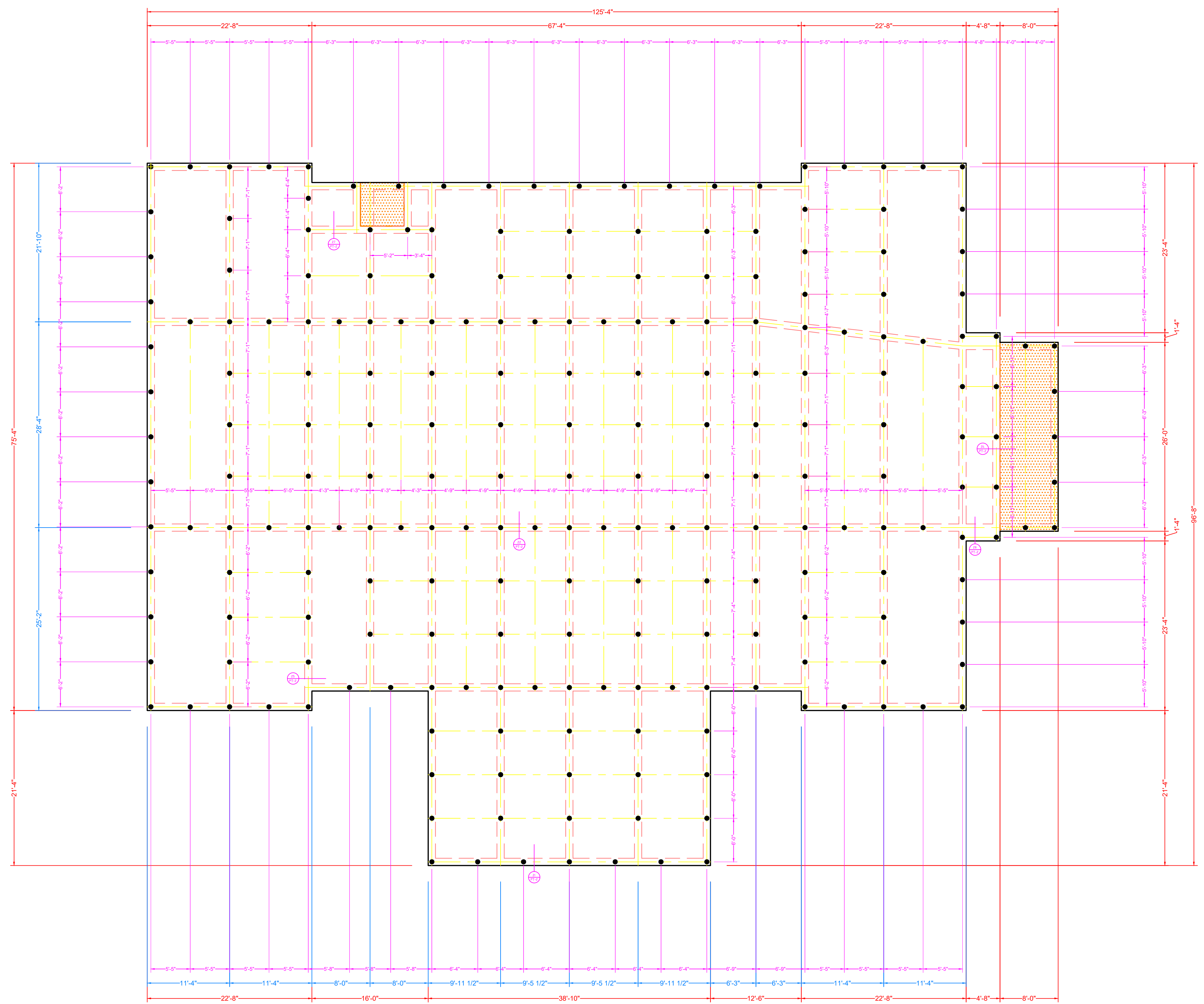

SCALE

1/8" = 1'-0"

INSTALLER NOTES

VISQUEEN PILES

225 PILES REQUIRED
 6 TON DESIGN LOAD
 PILES SHALL BE CLASS 5 PILES
 MIN. TIP EMBEDMENT INTO NATURAL SOIL = 30'-0"