

DAMMON ENGINEERING, INC.
EMMETT DAMMON

ARCHITECT
ROBERT WILTSE

554 OLD SPANISH TR.
SLIDELL, LA. 70458
985-649-5832

WEBSITE:
WWW.DAMMONENGINEERING.COM

EMAIL:
DAMMONENG@BELLSOUTH.NET

ARCHITECTURE
ENGINEERING
STUDIES
PLANNING
INVESTIGATION
EXPERT WITNESS

FREEDOM ALARM
P.O. BOX 399
ABITA SPRINGS
(985) 809-9639

NORTH OAK
MEDICAL CENTER
EXPANSION
PHASE I
15790 PAUL
VEGA MD DR.
HAMMOND, LA
70403

SECURITY ACCESS
DETAILS

REV: #1- 8/10/2012

SCALE:

JOB #: 2135

DATE:

SHEET: 5/4/2012

SEC 0.2

OF 17

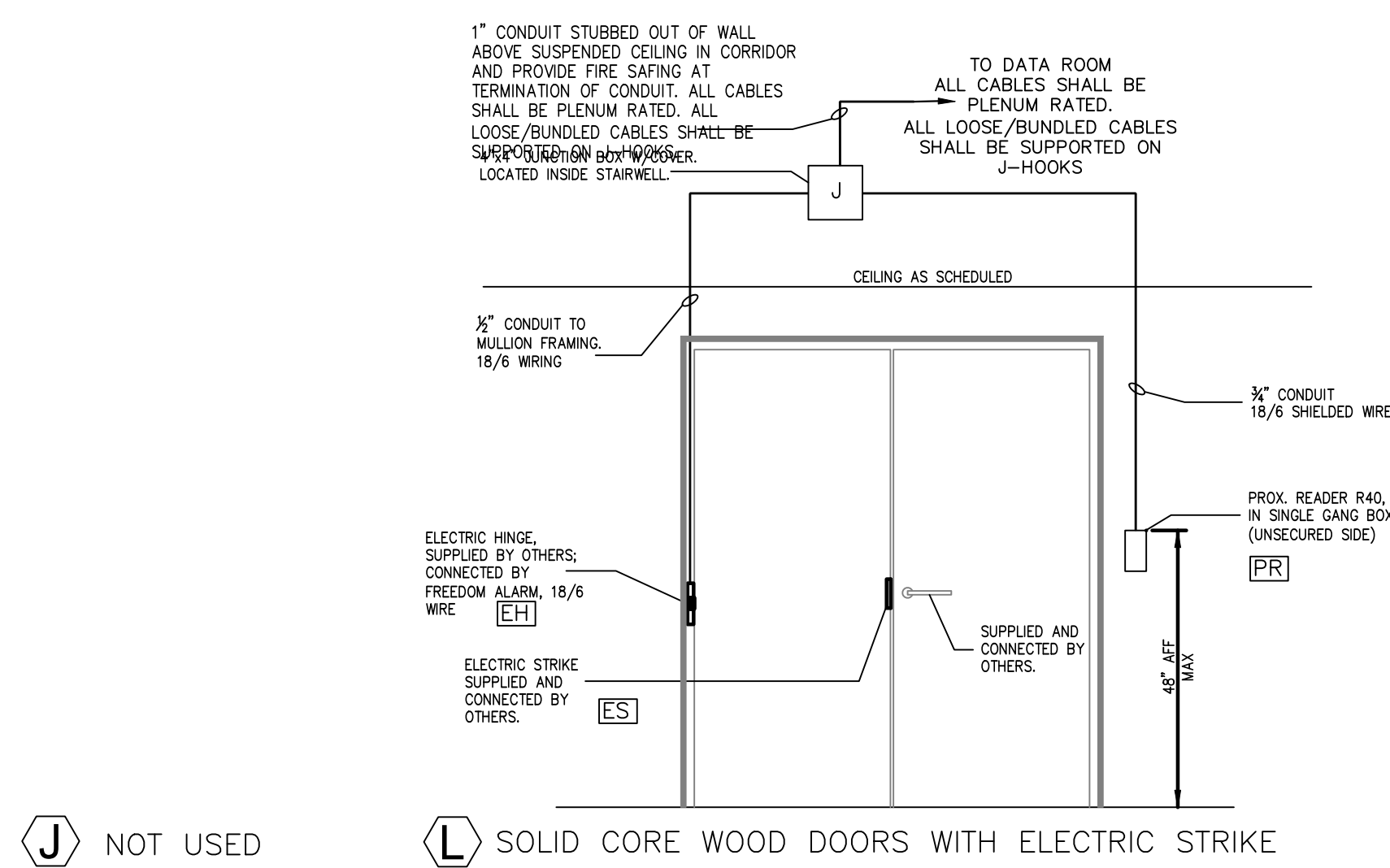

J NOT USED
K NOT USED

Door	R40 PR	R10 PR	MS	DP	EH
3011	1	0	0	0	ETW6
3015	1	0	0	0	QC8
3016	1	0	0	0	QC8
4015	1	0	0	0	QC8
4016	1	0	0	0	QC8
5006	1	0	0	0	QC8
5007	1	0	0	0	QC8

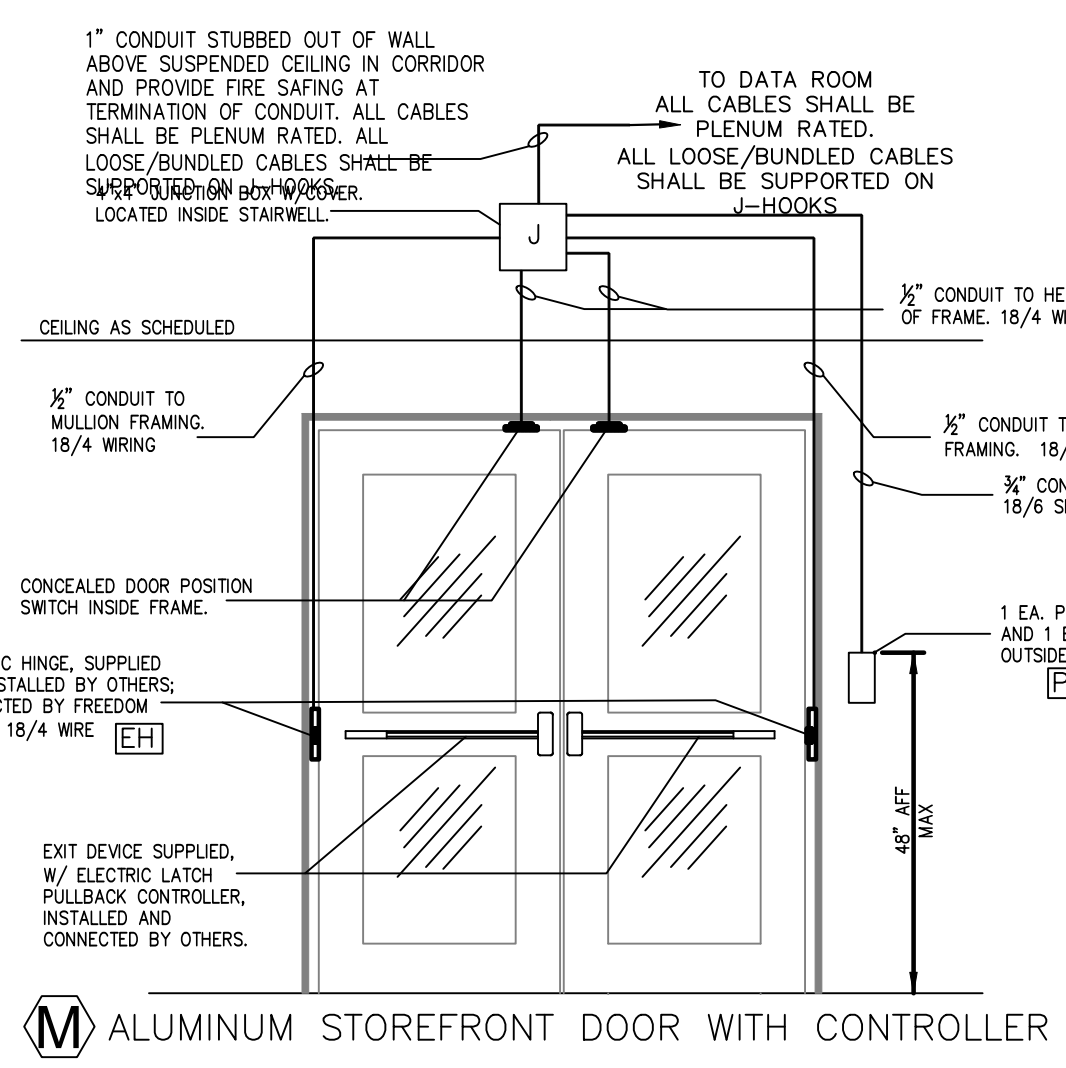

M ALUMINUM STOREFRONT DOOR WITH CONTROLLER

Door	R40 PR	R10 PR	MS	DP	EH
1301	1	0	0	2	QC8

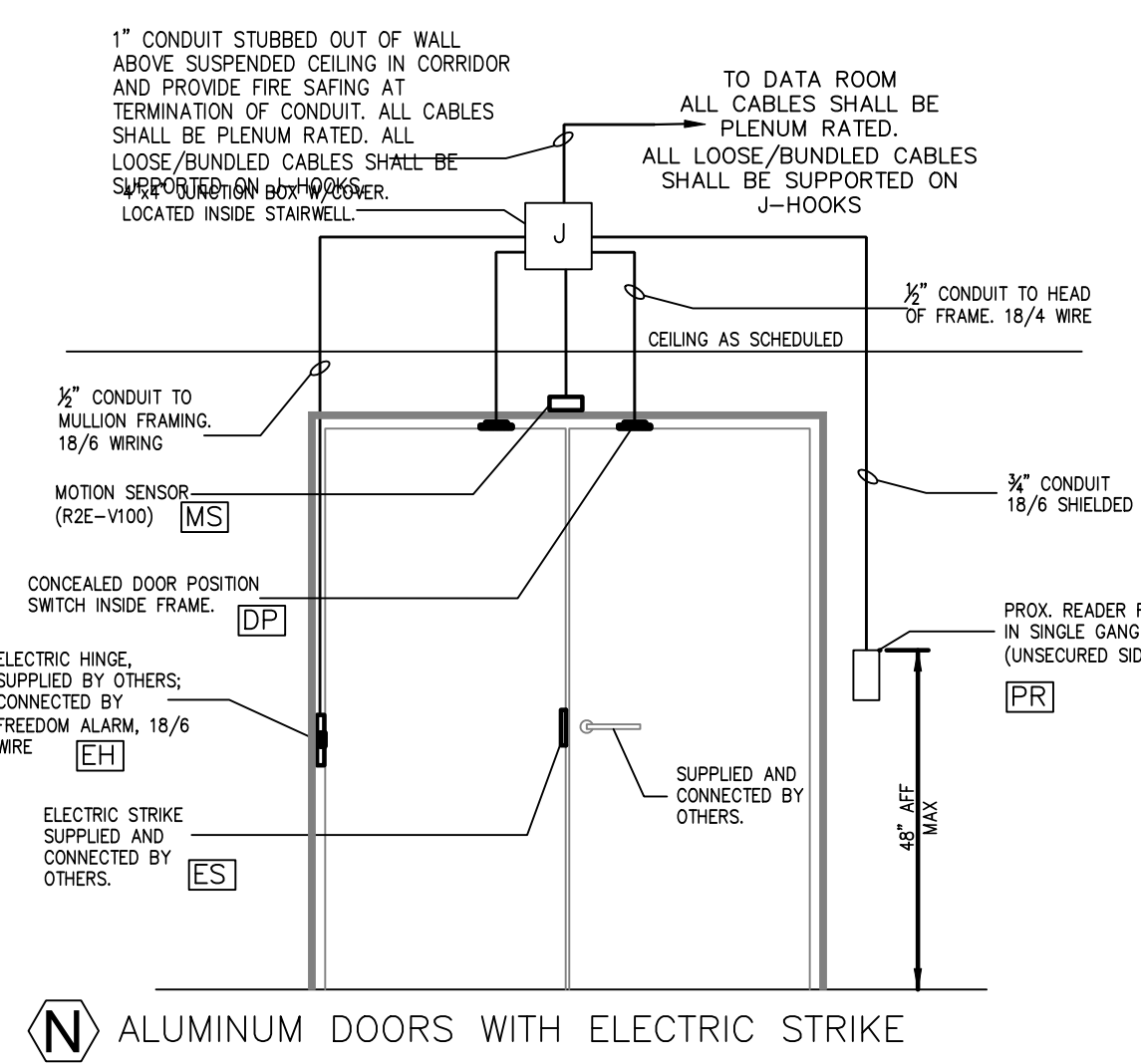

N ALUMINUM DOORS WITH ELECTRIC STRIKE

Door	R40 PR	R10 PR	MS	DP	EH
1332A	0	0	1	2	QC8

O NOT USED
P NOT USED
Q NOT USED

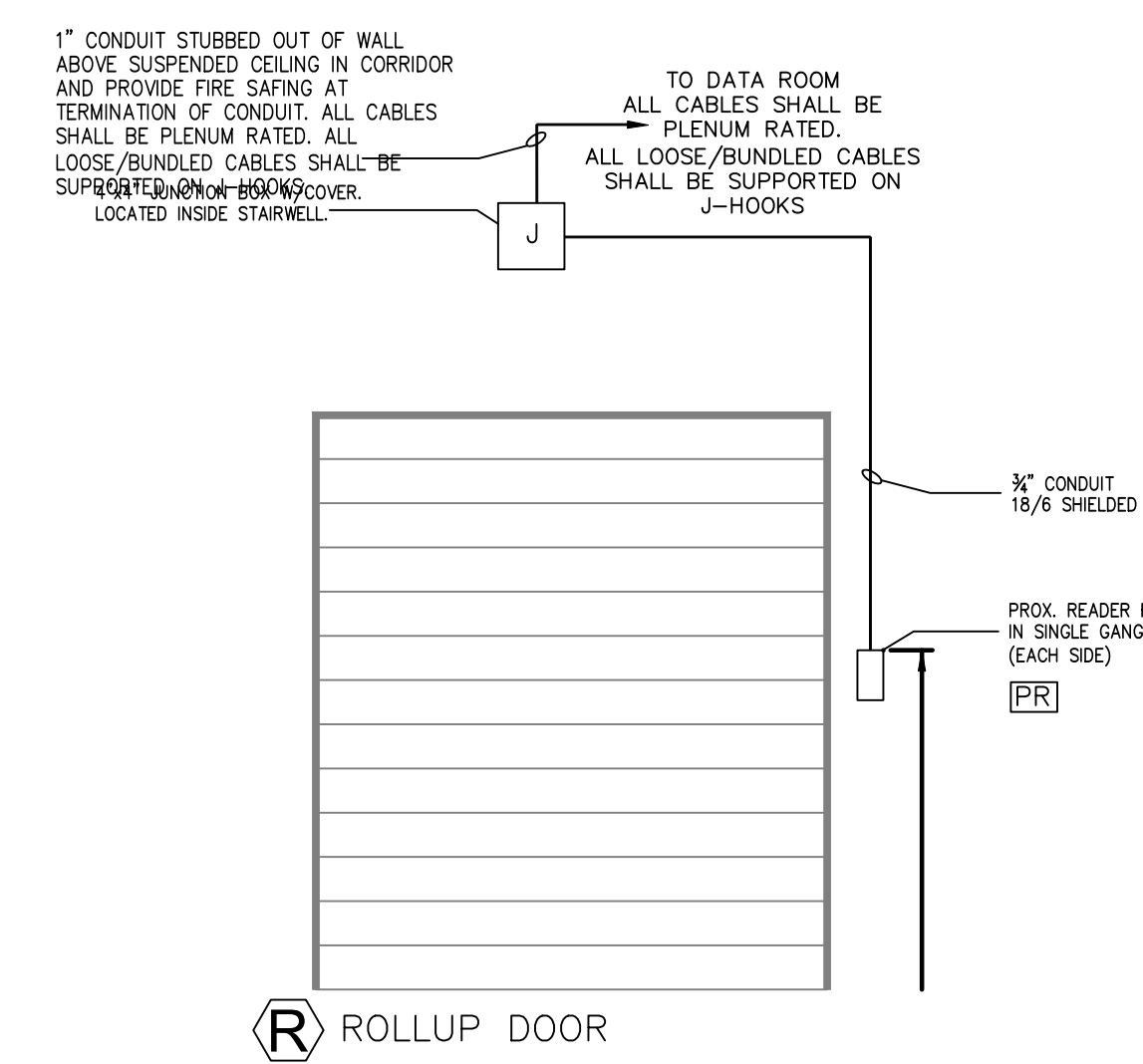

R ROLLUP DOOR

Door	R40 PR	R10 PR	MS	DP
2250A	2	0	0	0

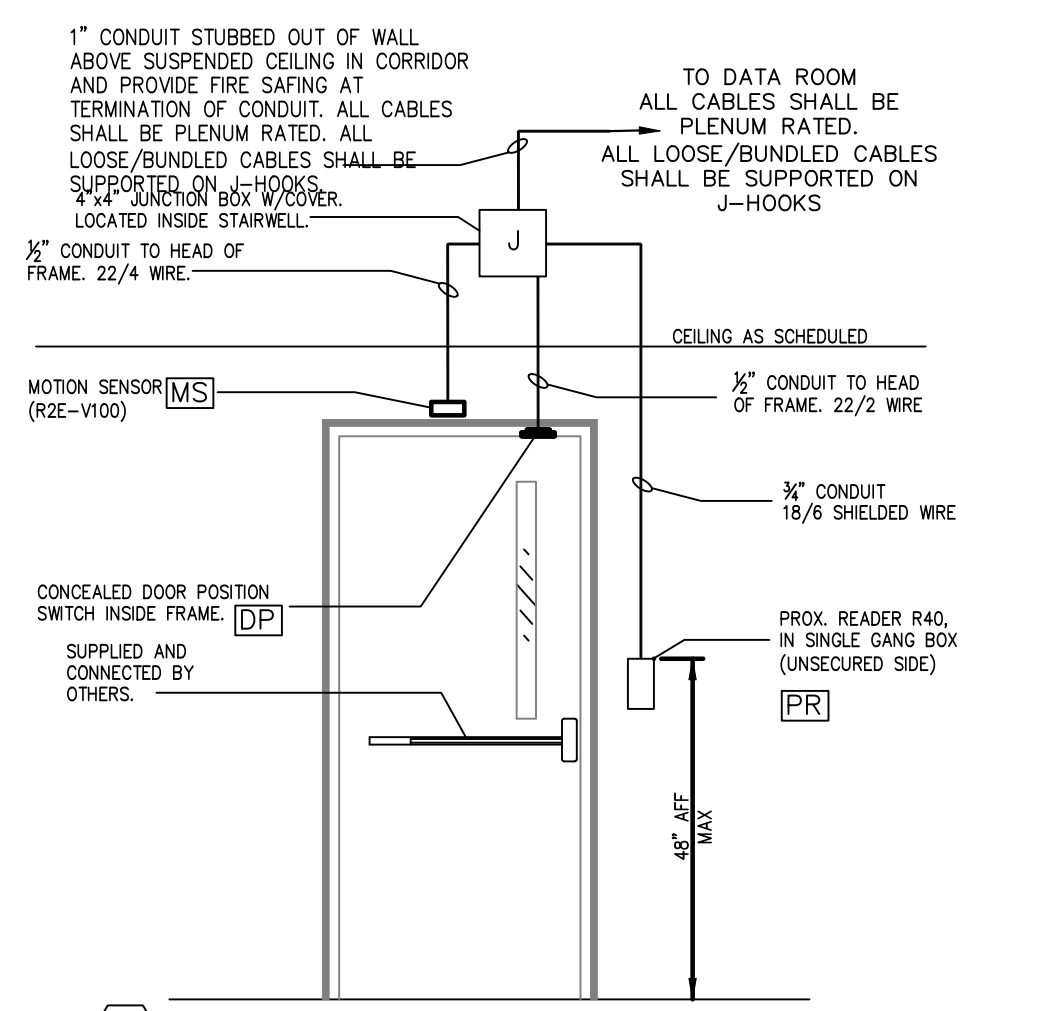

S ALUMINUM DOOR

Door	R40 PR	R10 PR	MS	DP
ST3-1	1	0	1	1

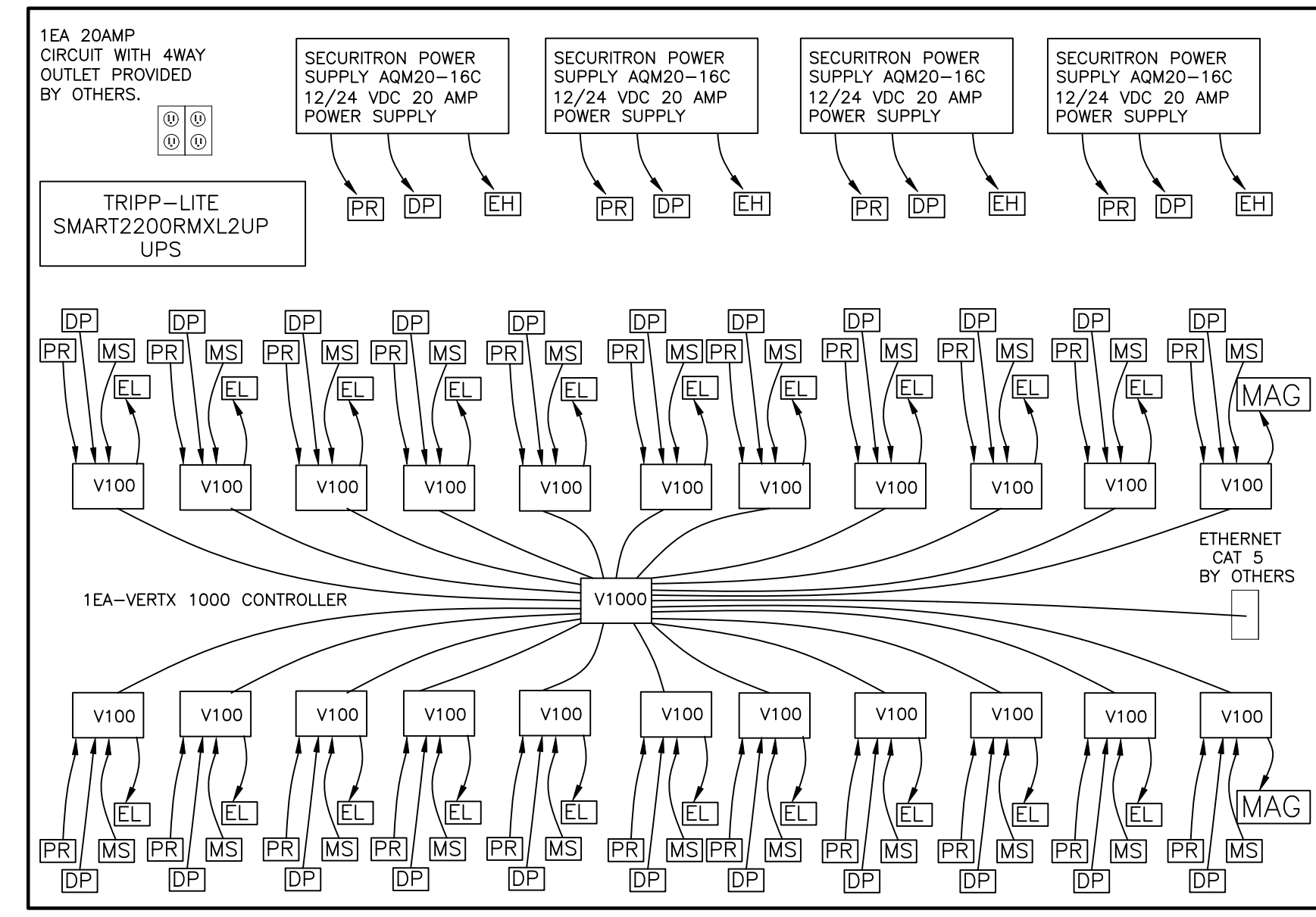

1st FLOOR 1323
EQUIPMENT ELEVATION

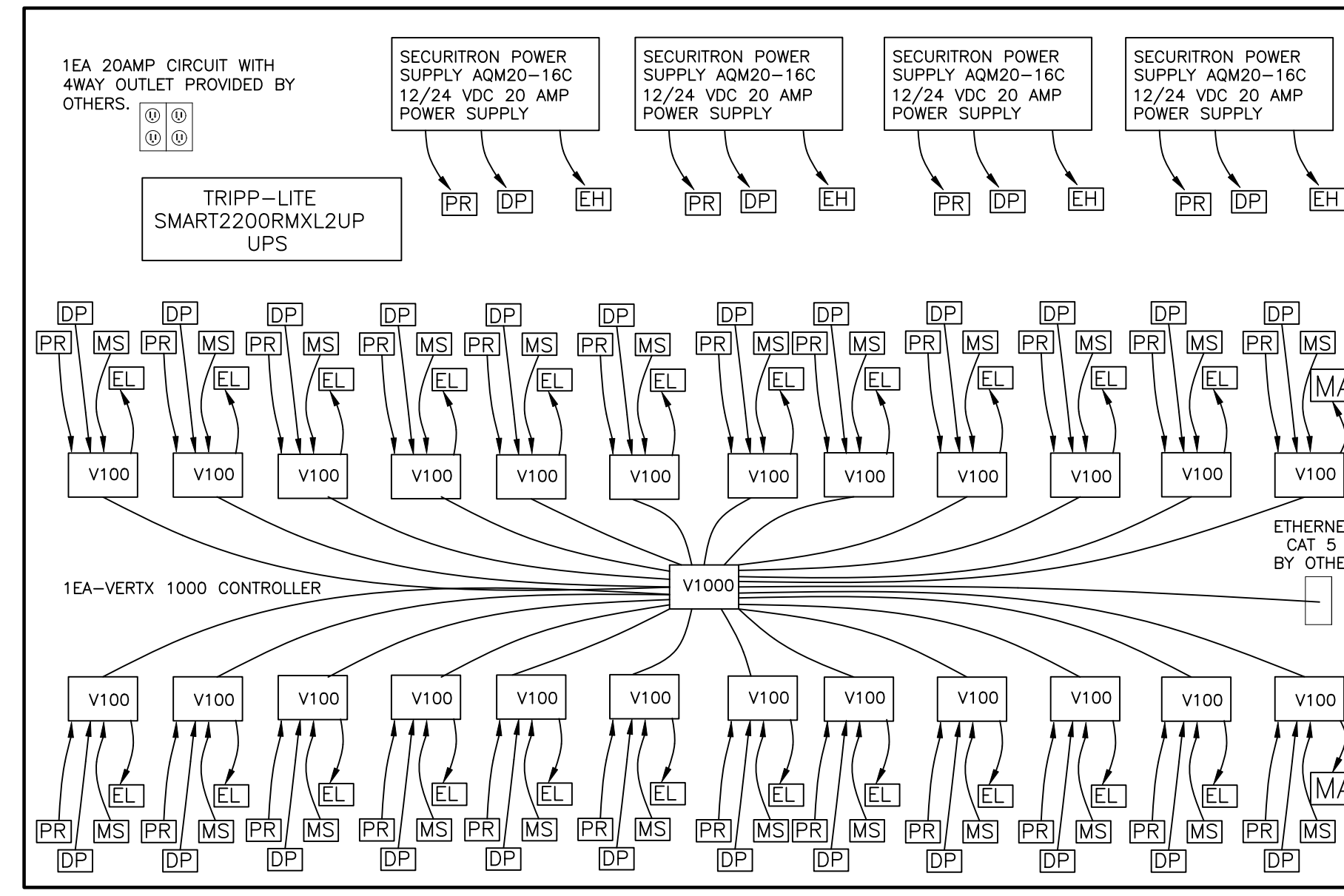

2nd FLOOR 2022
EQUIPMENT ELEVATION

#1 - 8/10/2012

ACCESS CONTROL SYMBOL LEGEND

- PR** = ICLASS R40 READER OR ICLASS R10 MULLION MOUNTED READER
- MS** = MOTION SENSOR
- DP** = SECURITRON DOOR POSITION SWITCH DPS-M
- EH** = ELECTRIC HINGE - BY OTHERS.
- EL** = ELECTRIC RELEASE LEVER - BY OTHERS
- MAG** = MAG LOCK - BY OTHERS
- J** = 4"x4" JUNCTION BOX
- ⊞** = PUSHBUTTON DOOR OPERATOR BY OTHERS.

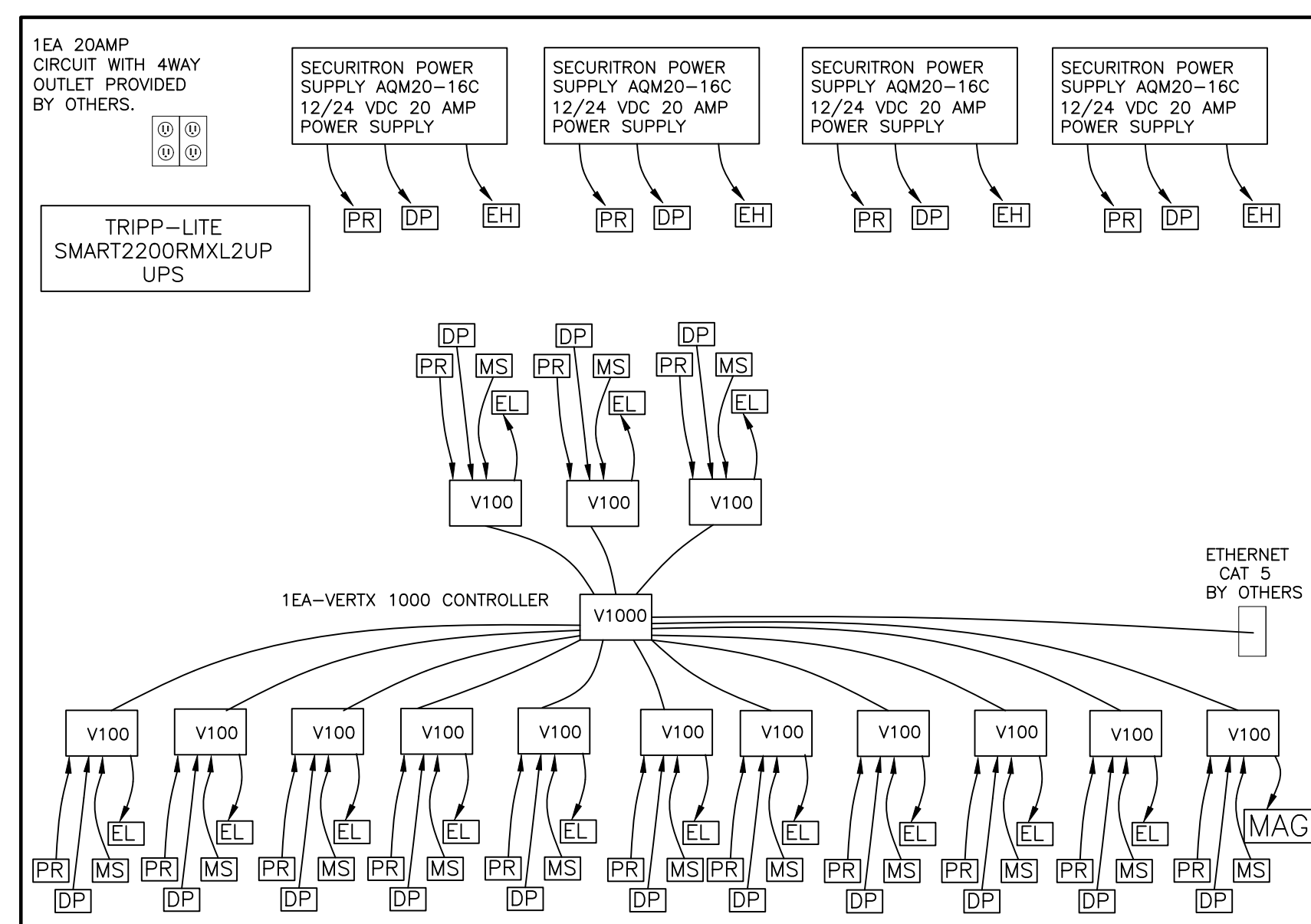

3rd FLOOR 3231
EQUIPMENT ELEVATION

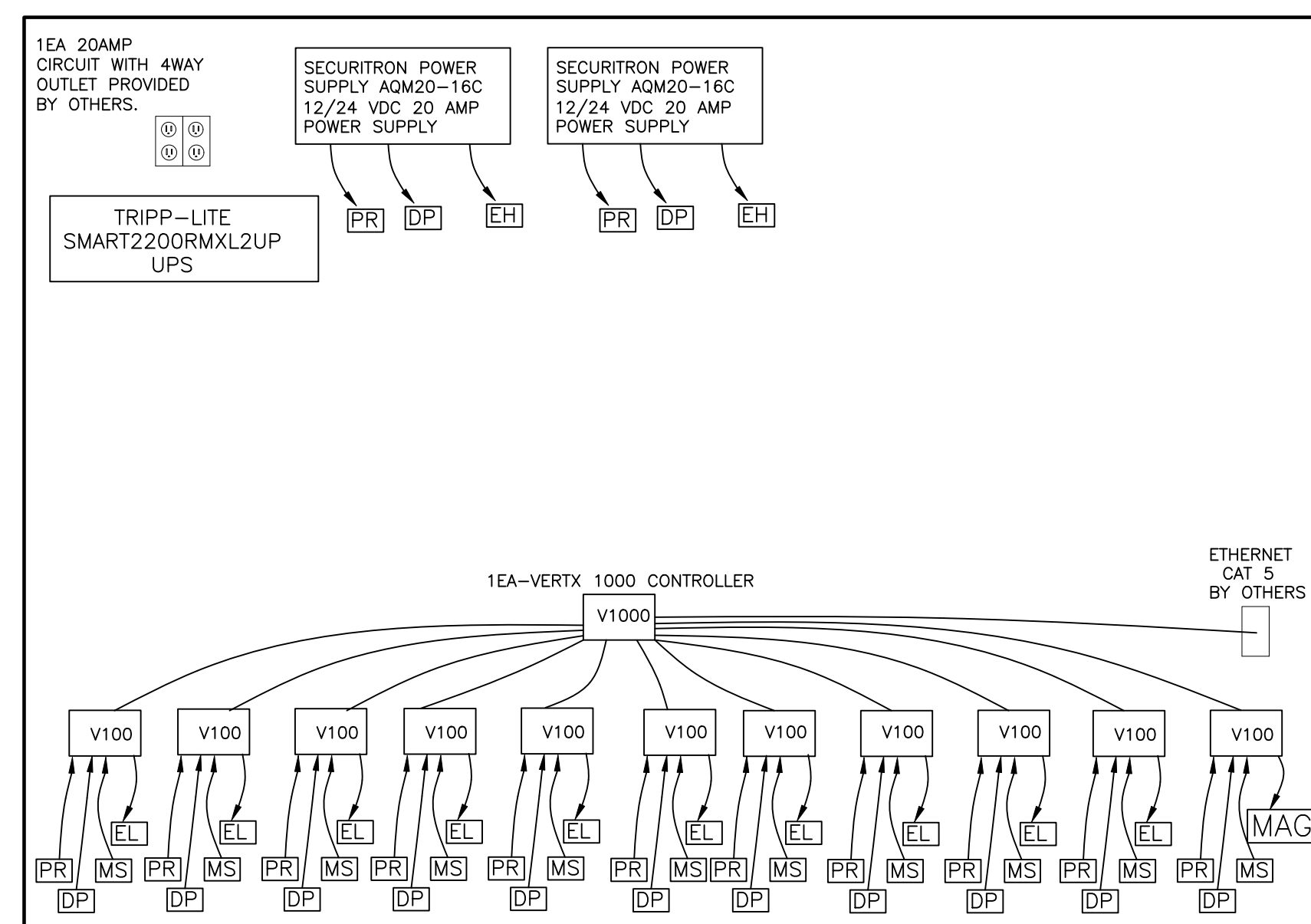

4th FLOOR 4231
EQUIPMENT ELEVATION

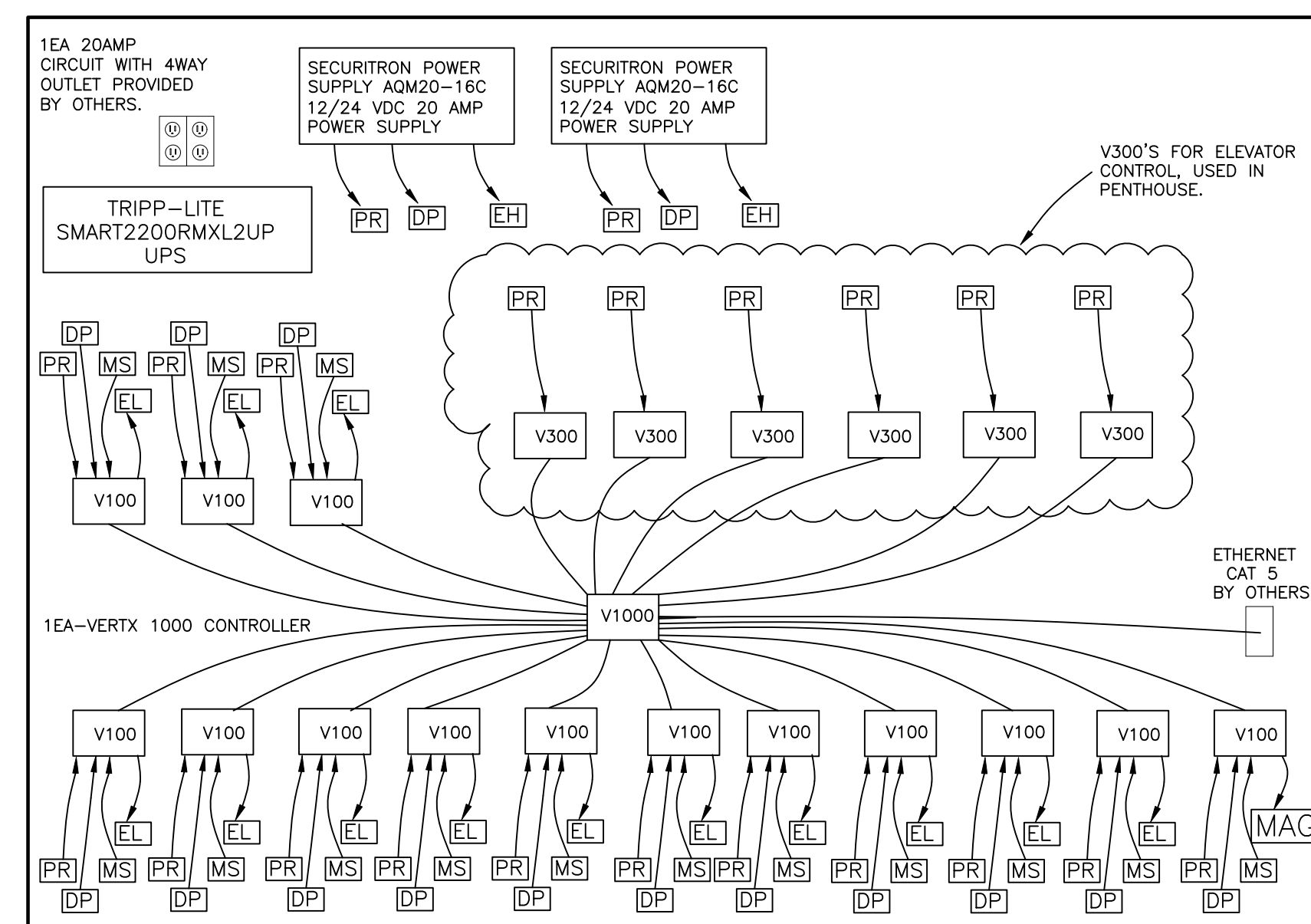

5th FLOOR 5241
EQUIPMENT ELEVATION

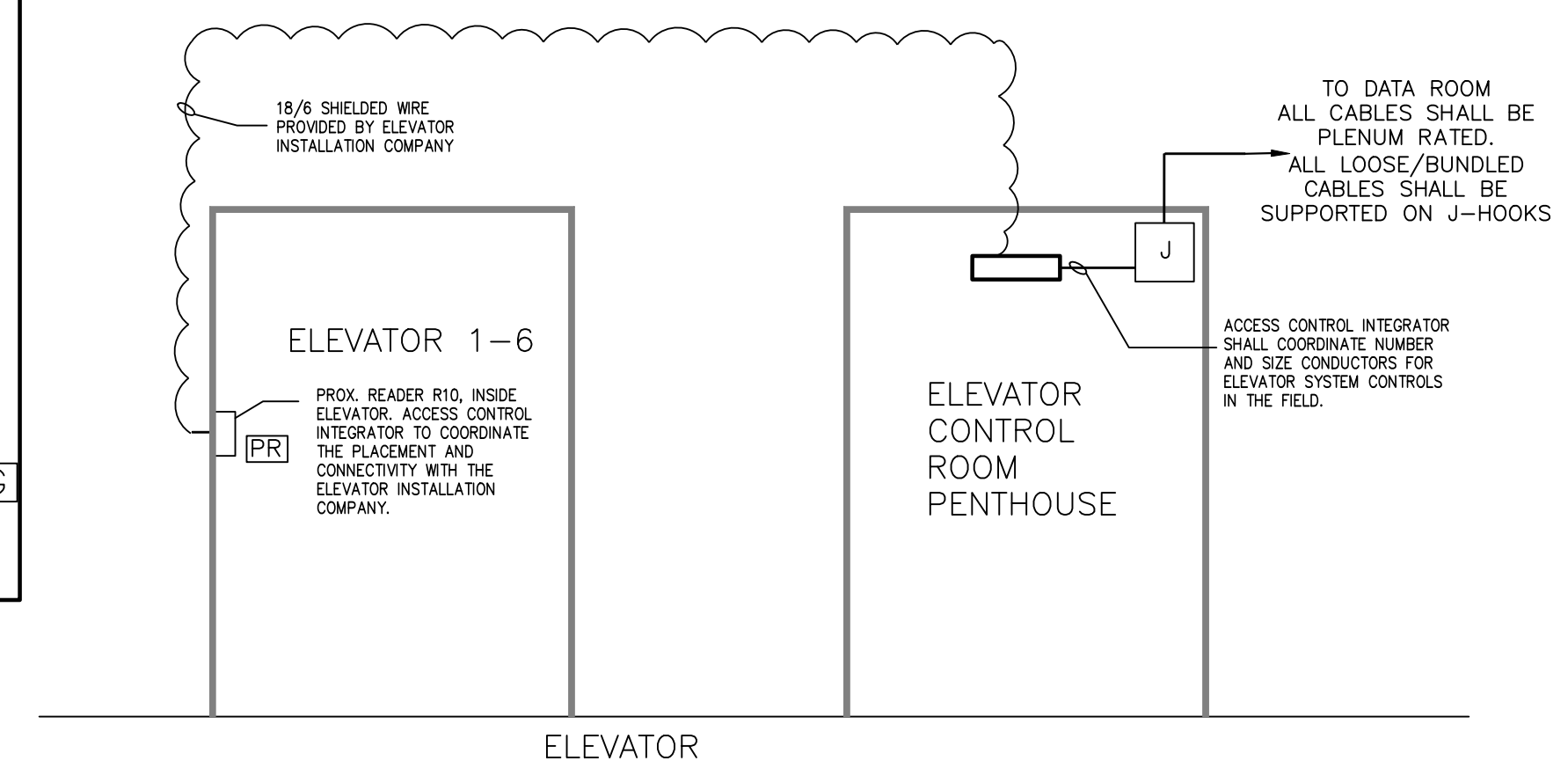

ELEVATOR